

# Troubleshooting & Repairing Switch Mode Power Supplies



Brought to you by Jestine Yong

<http://www.ElectronicRepairGuide.com>

<http://www.TestingElectronicComponents.com>

<http://www.LCD-Monitor-Repair.com>

<http://www.FindBurntResistorValue.com>

<http://www.JestineYong.com>

You cannot give this E-book away for free.  
You do not have the rights to redistribute this E-book.

## **Copyright@ All Rights Reserved**

Warning! This is a copyrighted material; no part of this guide may be reproduced or transmitted in any form whatsoever, electronic, or mechanical, including photocopying, printing, recording, or transmitting by any informational storage or retrieval system without expressed written, dated and signed permission from the author. You cannot alter, change, or repackage this document in any manner.

Jestine Yong reserves the right to use the full force of the law in the protection of his intellectual property including the contents, ideas, and expressions contained herein. Be aware that eBay actively cooperates in closing the account of copyright violators and assisting in the legal pursuit of violations.

## **DISCLAIMER AND/OR LEGAL NOTICES**

The reader is expressly warned to consider and adopt all safety precaution that might be indicated by the activities herein and to avoid all potential hazards. This E-book is for informational purposes only and the author do not accept any responsibilities or liabilities resulting from the use of this information. While every attempt has been made to verify the information provided here, the author cannot assume any responsibility for any loss, injury, errors, inaccuracies, omissions or inconvenience sustained by anyone resulting from this information. Most of the tips and secrets given should only be carried out by suitably qualified electronics engineers/technicians. Please be careful as all electrical equipment is potentially dangerous when dismantled. Any perceived slights of policy, specific people or organizations are unintentional.

### **Limit of Liability / Disclaimer of Warranty:**

**The authors and publisher of this book and the accompanying materials have used their best efforts in preparing this program. The authors and publisher make no representation or warranties with respect to the accuracy, applicability, fitness, or completeness of the contents of this program. They disclaim any warranties (expressed or implied), merchantability, or fitness for any particular purpose. The reader is expressly warned to consider and adapt all safety precautions that might be indicated by the activities here in and to avoid all potential hazards. By following the instructions contained herein, the reader willingly assumes all risks in connection with such instructions. The authors and publisher shall in no event be held liable for any loss or other damages, including but not limited to special,**

**incidental, consequential, or other damages. As always, the advice of a competent legal, tax, accounting or other professional should be sought.**

**This manual contains material protected under International and Federal Copyright Laws and Treaties. No parts of this manual shall be reproduced or transmitted by any means, electronic, mechanical, photocopying, printing and recording or otherwise. Any unauthorized use of this material is prohibited. All product illustration, product names and logo are trademark of their respective manufacturers.**

**If you have any information regarding the illegal reselling or duplication of this E-book, please report it to [jestineyong@electronicrepairguide.com](mailto:jestineyong@electronicrepairguide.com) for your reward.**

# **Dedication**

This book is dedicated to my  
“repair” friend cum technician, Mr Kent Liew for his support and  
encouragement.

# Content

## Part I

### Introduction to SMPS

1. Introduction to Switch Mode Power Supplies (SMPS).....	9
2. Identifying Electronic Components in Different Types of SMPS with the Help of Photos.....	14
3. Block Diagram of a Typical SMPS and How It Works.....	18
4. Easy Way To Understand The 11 Circuit Functions of SMPS With The Help Of Schematic Diagrams.....	24
4.1- Input Protection and EMI Filtering Circuit.....	26
4.2- Bridge Circuit.....	27
4.3- Start Up and Run DC Circuit.....	29
4.4- Oscillator Circuit.....	31
4.5- Secondary Output Voltage Circuit.....	34
4.6- Sampling Circuit.....	36
4.7- Error Detection Circuit.....	38
4.8- Feedback Circuit.....	39
4.9- Protection Circuit .....	40
4.10- Standby Circuit .....	50
4.11- Power Factor Correction (PFC) Circuit.....	56
5. Electronic Components Found In SMPS and Possible Causes.....	62
6. How To Find The Right Equivalent Components In SMPS Circuit.....	86

## Part II

### Secrets of SMPS Troubleshooting Techniques

7. Recommended Tools and Test Equipment For Successful SMPS Repair.....	95
7.1-Isolation Transformer.....	96
7.2-Variable Transformer.....	98

7.3-AC Ammeter.....	100
7.4-Analog and Digital Multimeter.....	102
7.5-Digital Capacitance Meter.....	104
7.6-Blue ESR Meter.....	105
7.7-Blue Ring Tester.....	106
7.8-Oscilloscope.....	107
8. Safety Guidelines.....	109
9. Understand The Six Common Problems Found In SMPS....	115
9.1-No Power.....	115
9.2-Low Output Voltage.....	117
9.3-High Output Voltage.....	118
9.4-Power Cycling/Pulsating/Blinking.....	118
9.5-Power Shutdown.....	121
9.6-Intermittent Power Problem.....	121
10. How to Easily Discharge The Main Capacitor In SMPS.....	122
11. How to Easily Perform Voltage Testing On SMPS Circuit...	127
12. How to Use Oscilloscope to Test SMPS Circuit Waveforms.	140
13. Find Out How Useful Is The Series Light Bulb Trick In SMPS Repairs.....	154
13.1-Light Bulb Off.....	156
13.2-Light Bulb Very Bright.....	157
13.2-Light Bulb Pulsating/Blinking (Slow or Fast).....	158
14. The Five Methods That I Use To Troubleshoot And Repair SMPS.....	161
14.1-Using the Blue Ring Tester Method.....	161
14.2-Flickering Method.....	165
14.3-Resistance Test Method.....	168
14.4-Isolation Method.....	170
14.5-Secondary Diode Removal Method.....	177
15. Simple Way For Beginners To Troubleshoot And Repair Any Type Of SMPS By Following My Favourite Method.....	179

16. What Should You Do If Too Many Components Burnt In The SMPS?.....189

17. How To Know If The Substitution Part Number Will Last Or Not.....195

### **Part III**

#### **True Case Histories**

18. 11 True Case Histories of SMPS Repair That You Should Not Miss.....200

## **PART IV**

### **Troubleshooting and Repairing ATX Power Supply**

19. Troubleshooting And Repairing ATX Power Supply .....227

20. ATX Power Supply Repair True Case Histories.....245

## **Part V**

### **Miscellaneous**

21. Understanding Power Supply Glossary Terms.....262

22. Recommended Electronic Repair E-Books.....267

23. Recommended Resources.....269

24. Conclusion.....271

**Part I**

**Introduction to  
SMPS**



# 1) Introduction to Switch Mode Power Supply (SMPS)

What is SMPS? SMPS stands for switch mode power supply. The function of SMPS is to transform the voltage from one level to another. Typically it is taken from the AC mains and transformed into regulated DC voltage(s) required for electronic circuits or equipment.

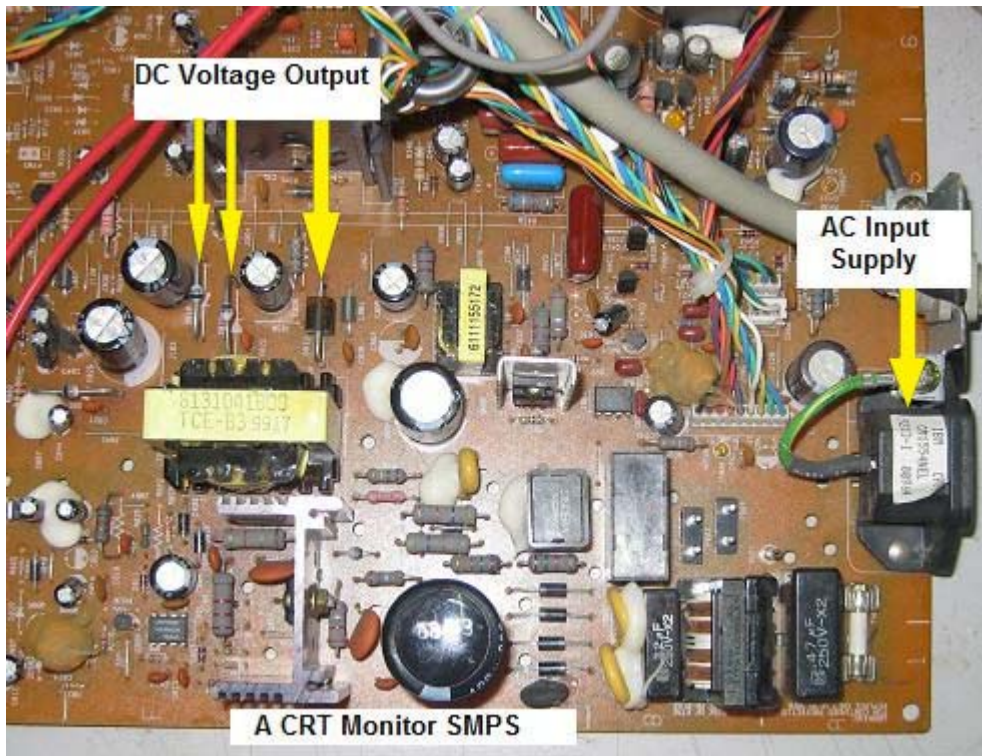
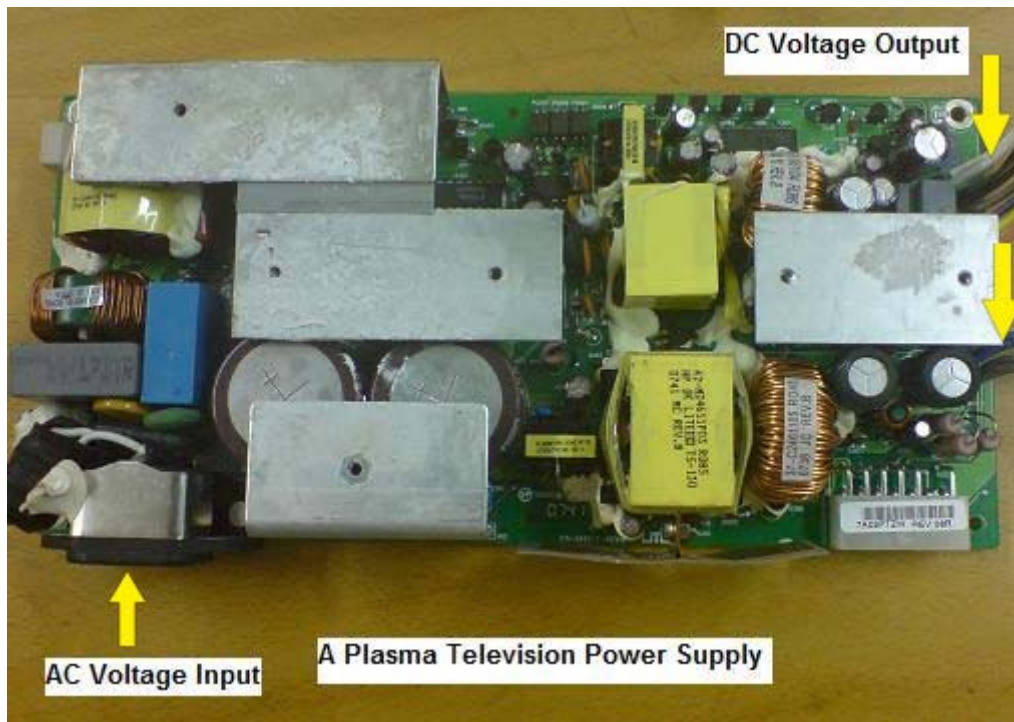


Figure 1.1- CRT Monitor SMPS

Switch mode power supplies have gained much popularity since in the beginning of 80's because of the benefits they offer. The **advantages** of the SMPS are:

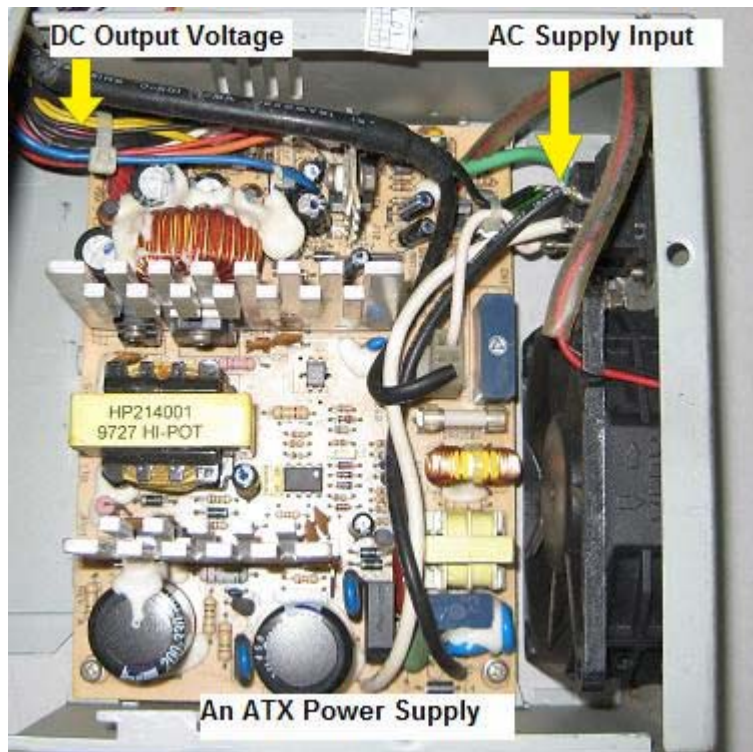
- Smaller size and lighter weight
- High Efficiency and less heat generation
- Better regulation
- Wide range of AC input and
- Low cost



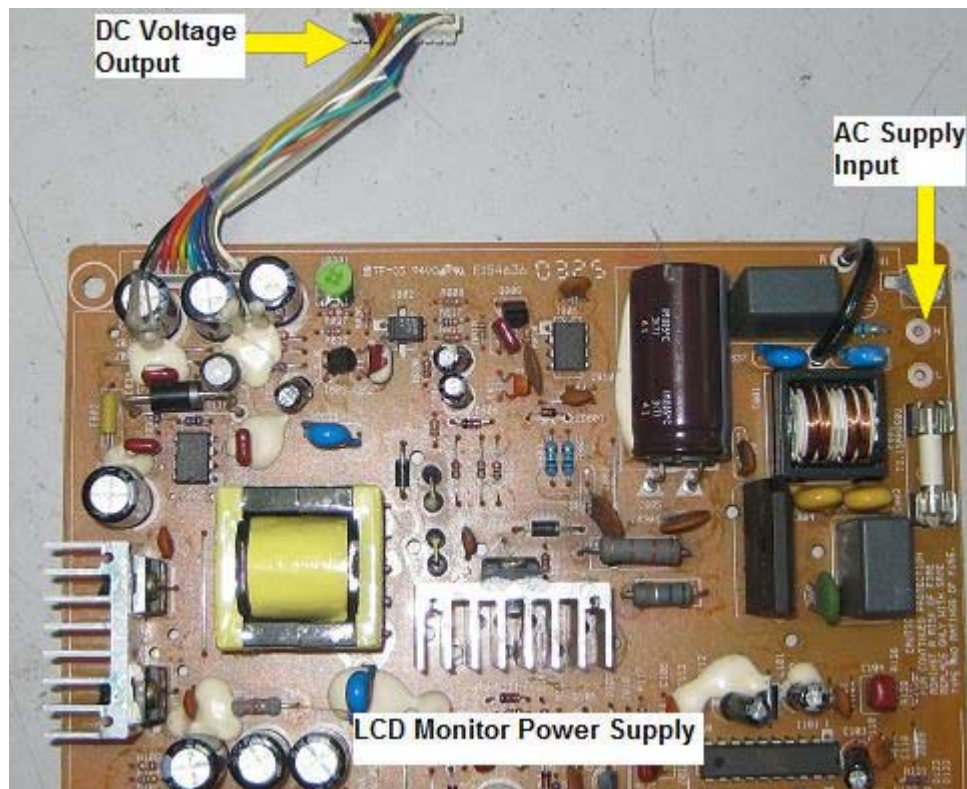
**Figure 1.2- Plasma Television SMPS**

Switch mode power supplies have also some **disadvantages** in comparison with the linear power supplies such as:

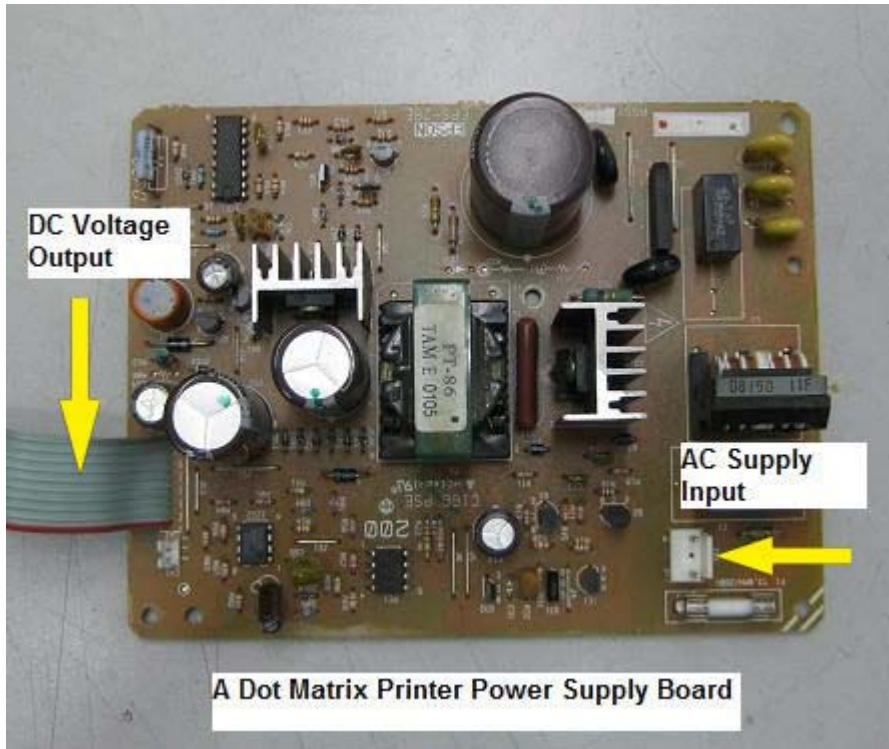
- 1) Because of more electronic components used in the power supply circuit and when failure occurs, it could take out many parts in the SMPS for example; lightning strikes on the SMPS.
- 2) With so many different type of circuits used in the design of a SMPS such as oscillator, feedback, protection, start up and etc and when problem happens it could actually cause complication when it comes to troubleshooting and repairing the SMPS.
- 3) Some spare parts are expensive and quite hard to get from the market for example; power FETs, power ICs and switch mode transformer.
- 4) Strong Electromagnetic interference (EMI) generated by the SMPS, without proper shielding can cause the computer or other devices to generate intermittent problems.
- 5) Strong induced voltages get feedback to the mains, thus polluting the main supply to other devices in use nearby.



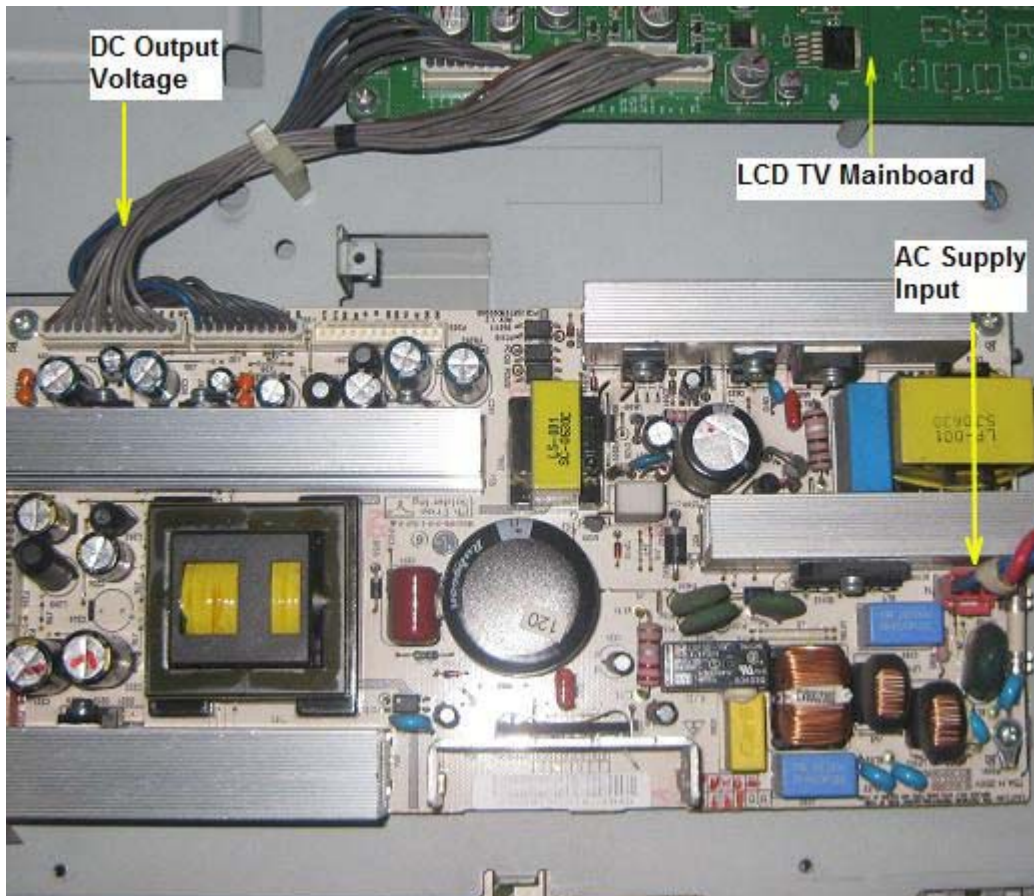
**Figure 1.3- ATX SMPS**



**Figure 1.4- LCD Monitor SMPS**



**Figure 1.5- Dot Matrix Printer SMPS**



**Figure 1.6- A 32" LG LCD TV Power Supply**

### **Where is SMPS used?**

To reduce cost, size and weight, Monitors, TVs, Mobile charger, PCs, laptop and camcorder power packs, printers, fax machines, VCRs, portable CD players, DVD players, microelectronics-based devices in automotive, computing, communications, consumer electronics, and industrial applications use SMPS.

# 2) Identifying Electronic Components In Different Types Of SMPS With The Help Of Photos

I will expose to you different types of SMPS with the help of photos so that you can be familiar with the section and components used in SMPS. With the information provided in the photos, I'm sure you will be well prepared in troubleshooting and repairing SMPS in the future.

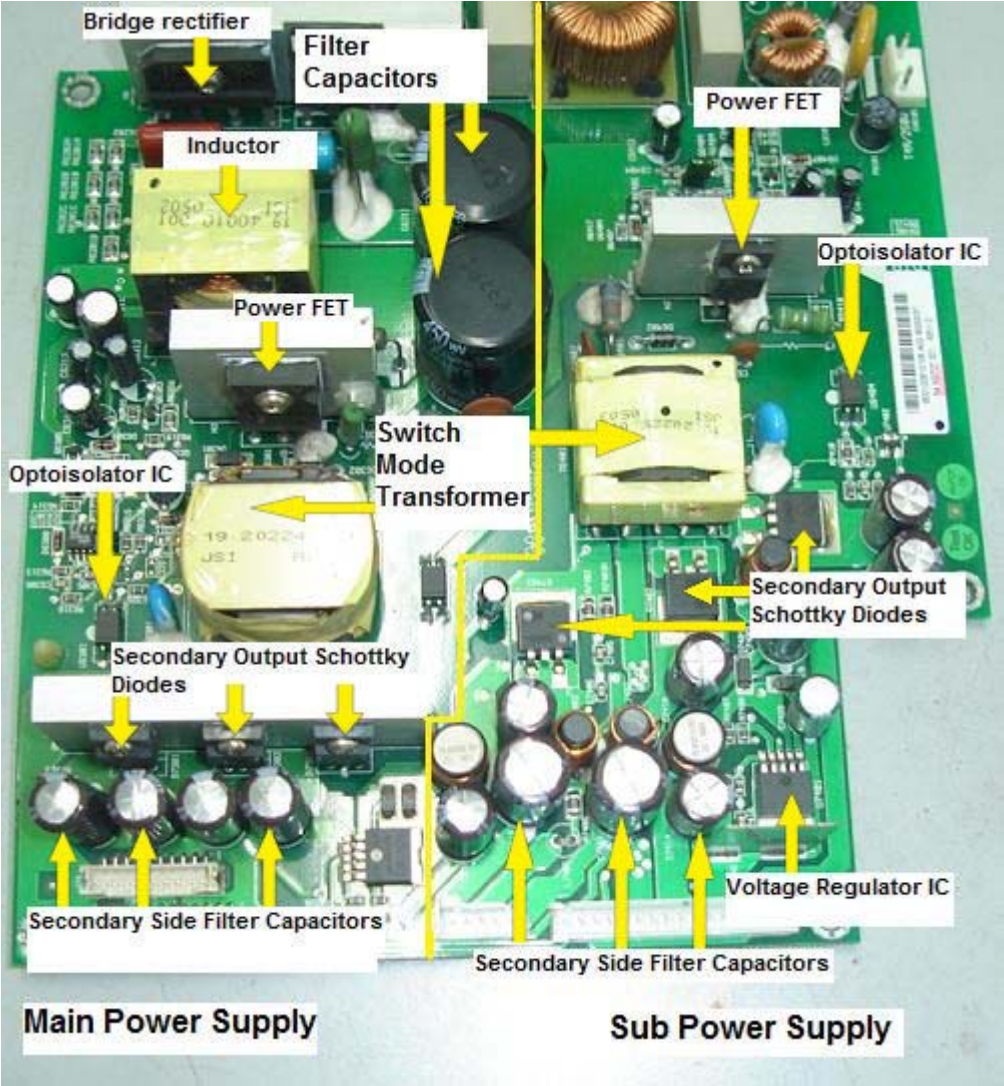
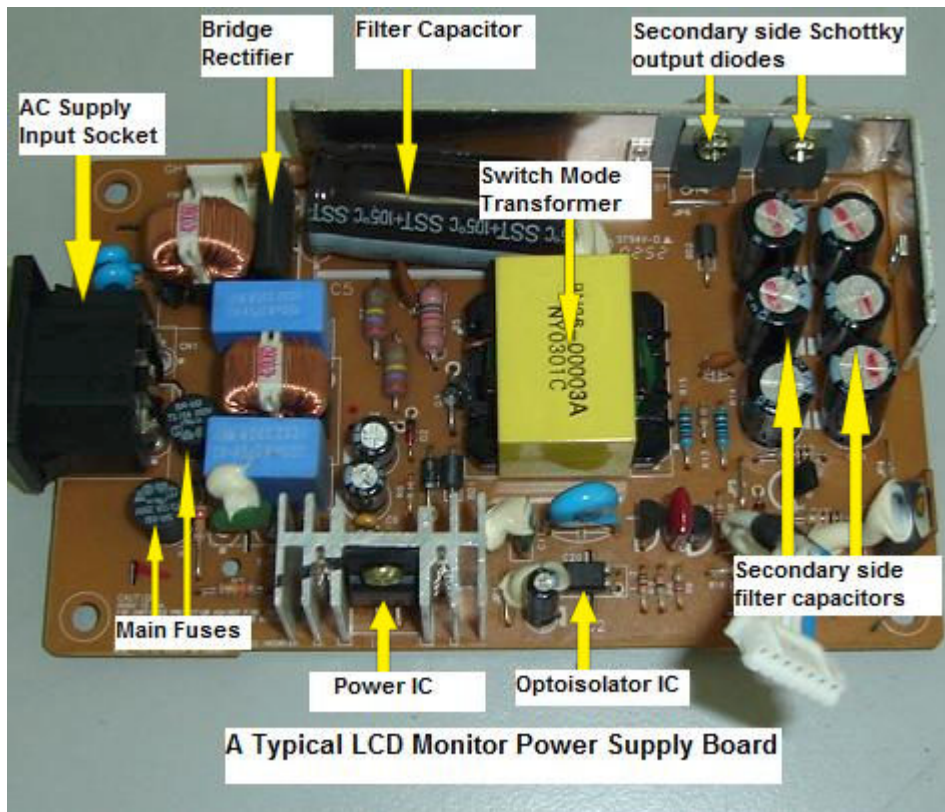
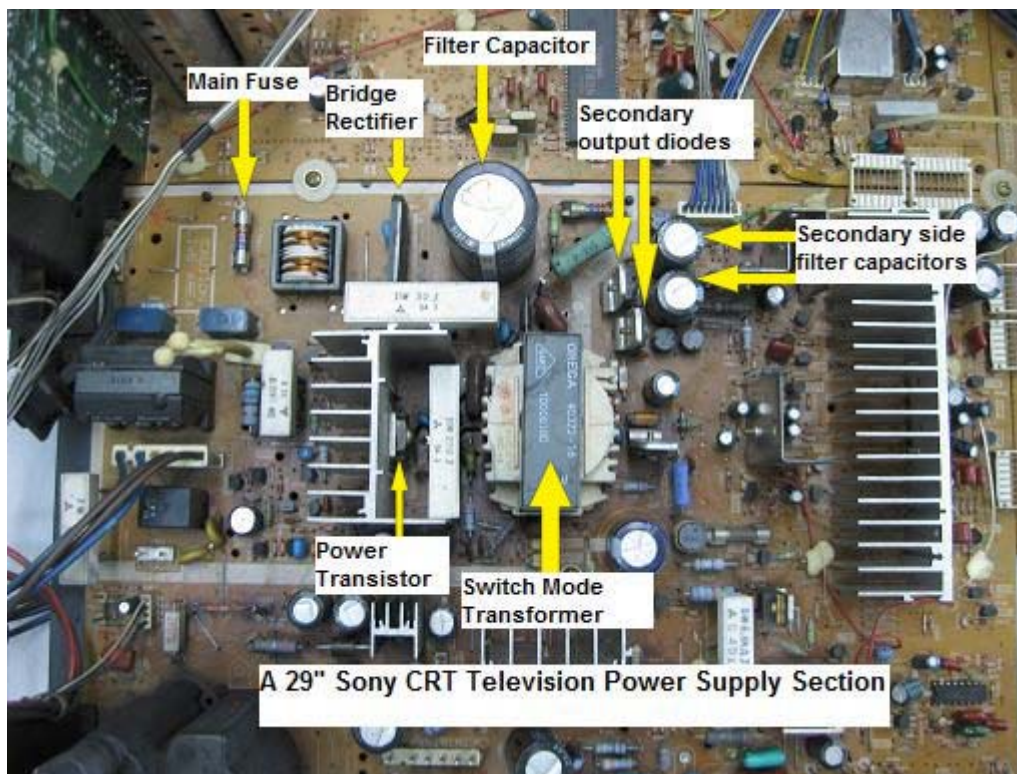


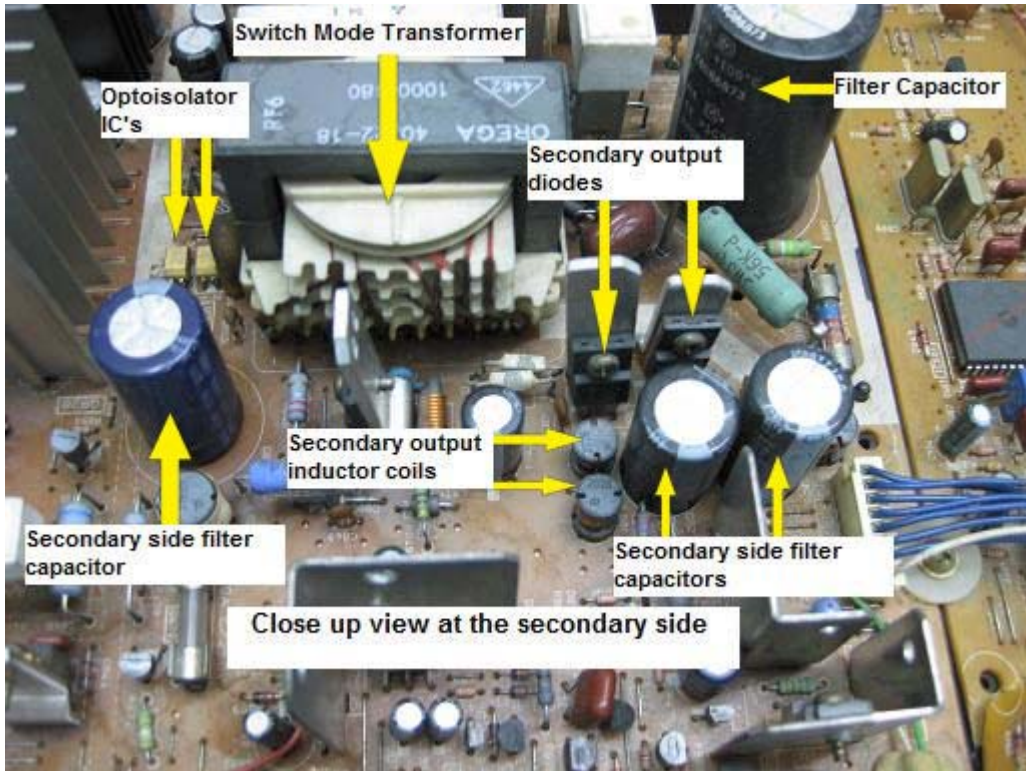
Figure 2.1- A Typical LCD TV SMPS



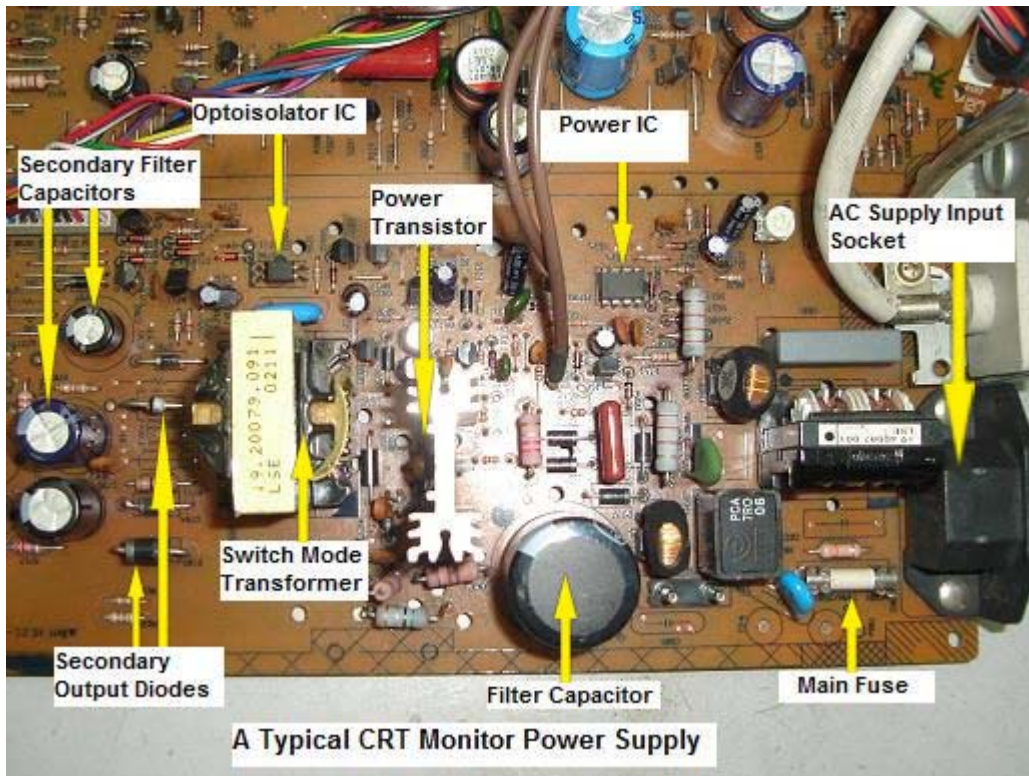
**Figure 2.2- A 15" Samsung LCD Monitor SMPS**



**Figure 2.3- A 29" Sony CRT Television SMPS (Primary Side)**

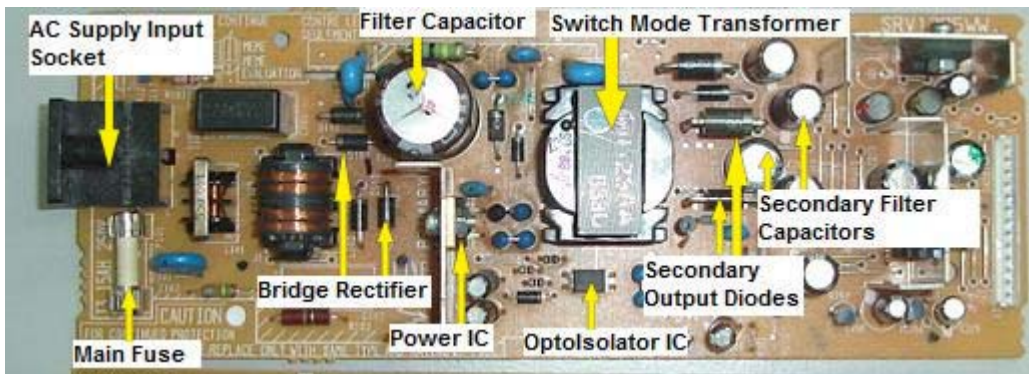


**Figure 2.4- A 29" Sony CRT Television SMPS (Secondary Side)**

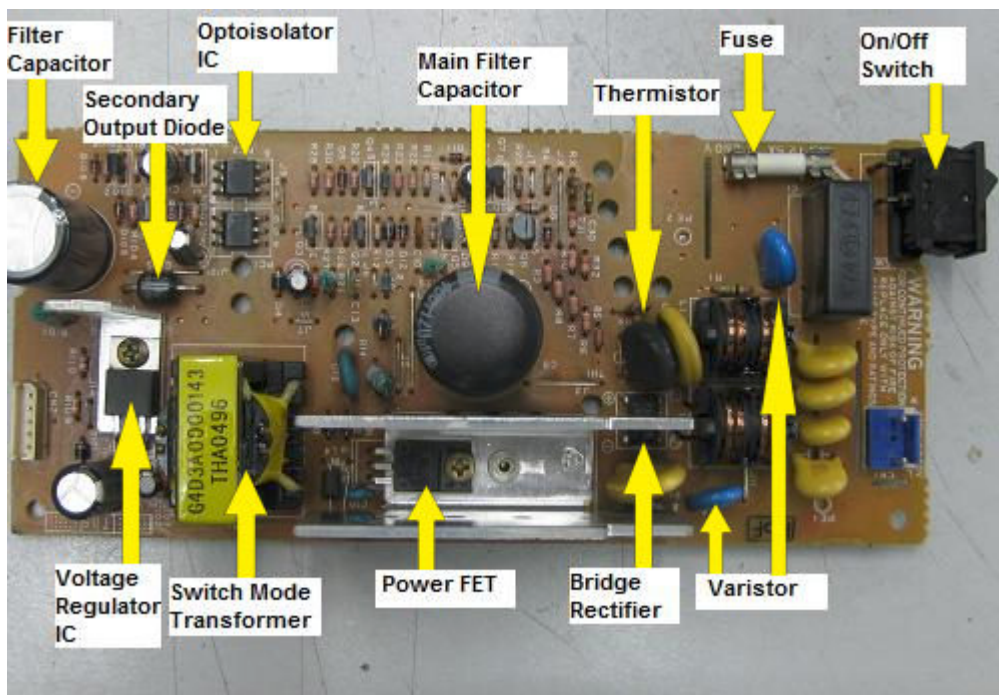


**Figure 2.5- A Typical CRT Monitor SMPS**





**Figure 2.6- A Typical Satellite Receiver SMPS**



**Figure 2.7- A Typical Dot Matrix Printer SMPS**

If you have seen all the photos, you will notice that almost all of the power supplies (although the power supplies use different electronic equipment) use common electronic components like Fuse, Bridge Rectifier, Filter Capacitor, Power IC, Power FET, Switch mode transformer, Optoisolator IC, Secondary output diodes, Secondary filter capacitors and etc. Due to this configuration, if you carefully study how power supply works (with the help of block and schematic diagrams) and know **how to test electronic components** in the power section, I don't see any reason why you can't successfully repair any power supply.

### 3) Block Diagram Of A Typical SMPS And How It Works

The power supply repair is one of the most challenging tasks for an electronic repairer and once you have mastered the circuit and the repair technique, to troubleshoot other type of circuits such as the colour, vertical, audio, high voltage and so forth would be much easier. If you are aware of how power supply or switch mode power supplies work, then you are ready to repair any kind of power supply problems in any type of equipment which include the smaller power supplies used in the **notebook or the laptop (Both equipment use smaller size of electronic components but the working principle is the same)**. Basically, all of the power supply functions are almost the same which is to produce output voltages for various secondary circuits.

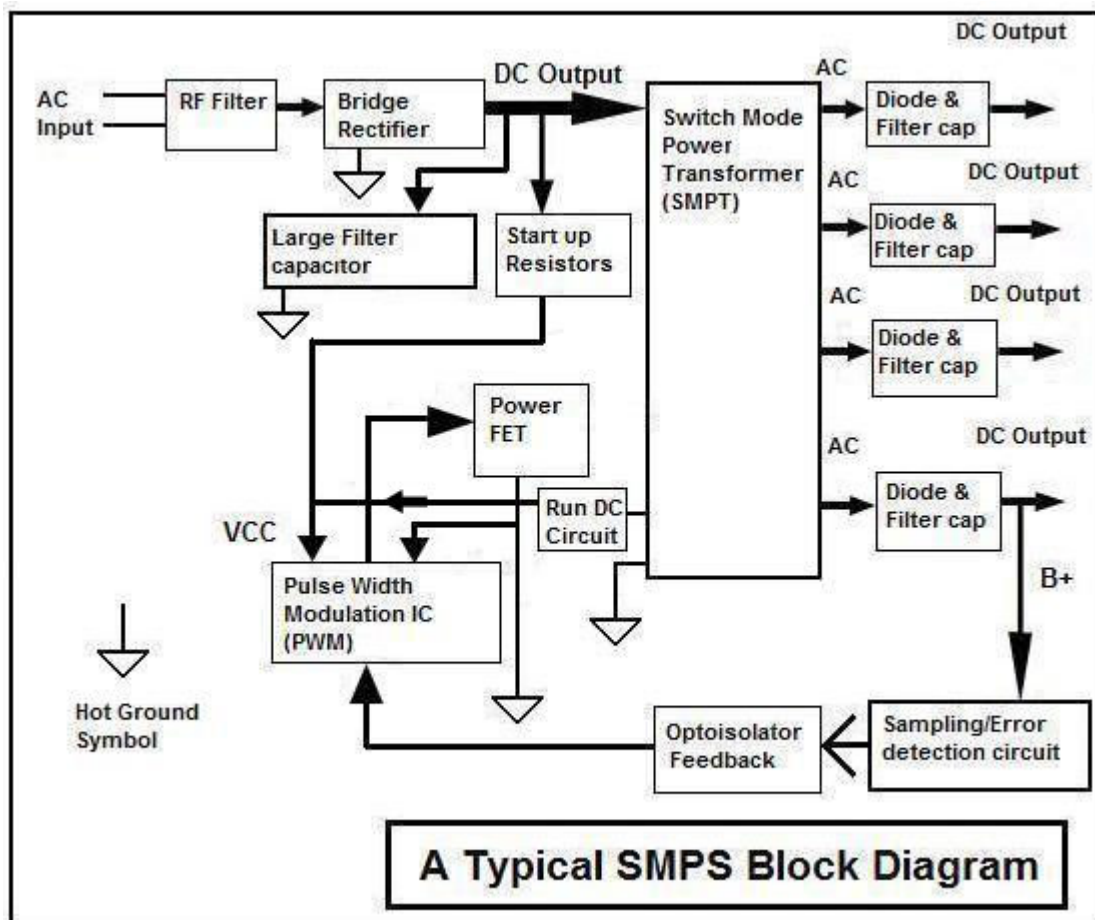


Figure 3.1- A Typical SMPS Block Diagram

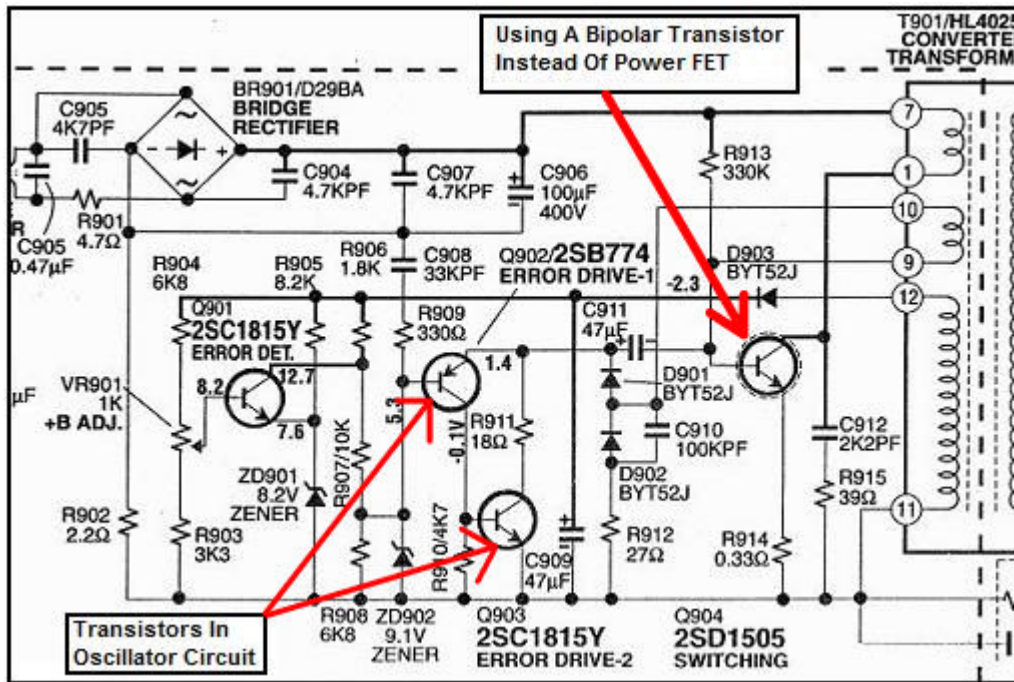
The working principle of switch mode power supply is different from the linear type. First the AC voltage enters the RF filter circuit where its function is to prevent the Power Supply unit from causing interference on the main wiring and to a full wave rectifier (bridge rectifier) which converts the AC to produce an uneven DC output and then filter by a large filter capacitor (usually 220 Micro Farad and up to 450 volts).

The clean DC voltage will then be given to start up resistors and to the input of switch mode power transformer. Once the voltage passed through the high ohms resistor (start up resistors) the voltage would drop to a value where it then goes to the VCC supply pin of Pulse width modulation (PWM) IC. The **Run DC circuit** that consists of a resistor and a diode will maintain the power IC stable operation.

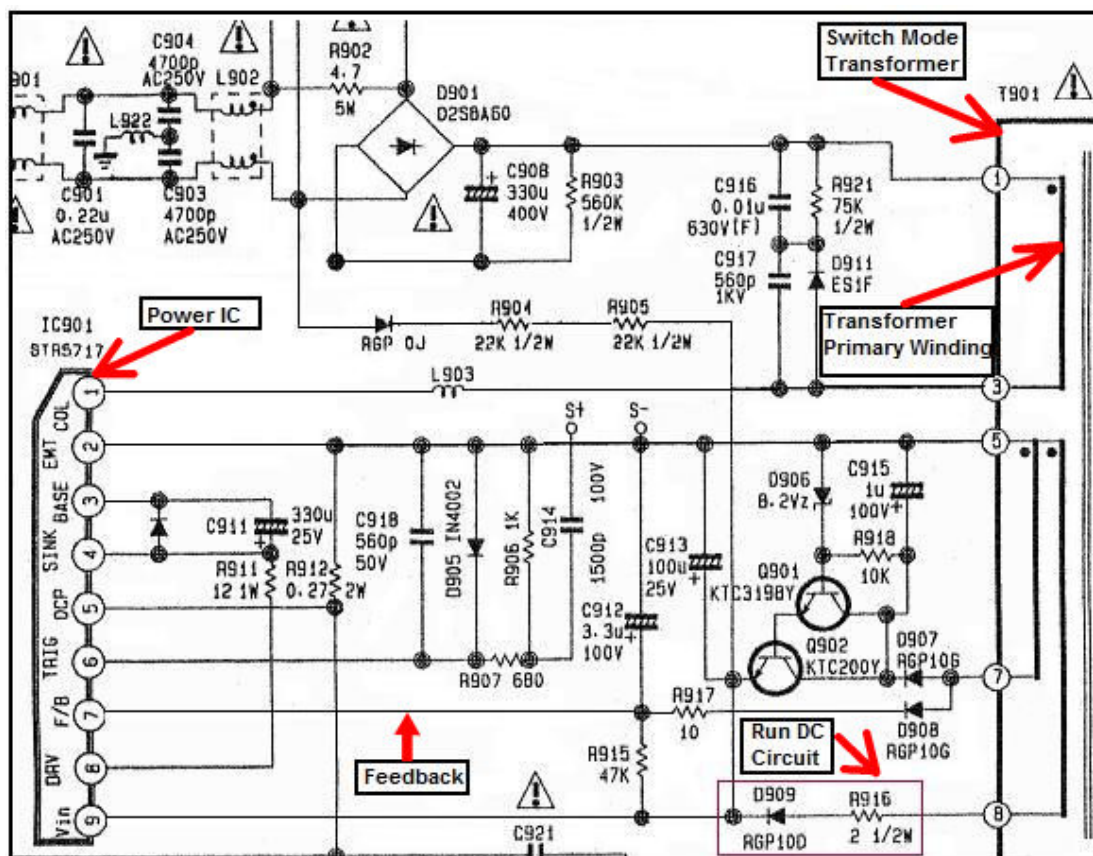
Once the PWM IC received the voltage, it will produce a signal to drive the transistor (normally FET) and produces a change in the magnetic field in the transformer primary winding. The changing magnetic field induces voltage in the secondary windings.

Each of these AC voltage produced by the secondary windings is then rectified, filtered, and regulated to produce a clean DC voltage. One of the main DC output voltages is the B+ voltage. The output from the B+ voltage supply is then connected, through a sampling error detection circuit and “feedback” loop back to the PWM IC. When the voltage from the B+ supply rises or drop a bit, the PWM IC will act to correct the output.

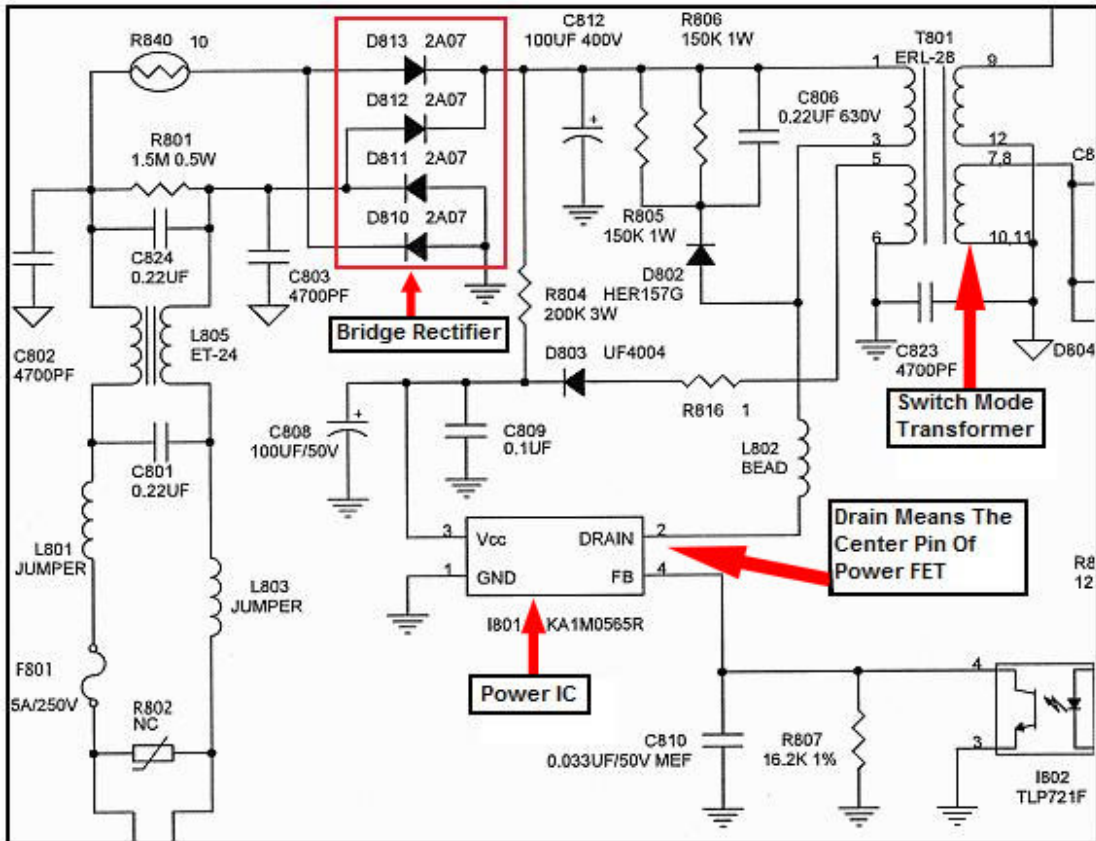
**Note:** Not all SMPS designs are base on the block diagram in figure 3.1. Some older SMPS do not use the PWM IC to drive the FET (some use the bipolar transistor) instead they use an oscillator circuit which consists of some components to drive the FET/Bipolar transistor as seen in figure 3.2. **Some do not have the sampling error detection/feedback circuit at the secondary side but instead it was taken from the primary side as seen from figure 3.3.** In newer designs, you would not find the Power FET because it has been integrated into the Power IC as shown in figure 3.4.



**Figure 3.2- A Typical Television SMPS That Do Not Have Power IC**



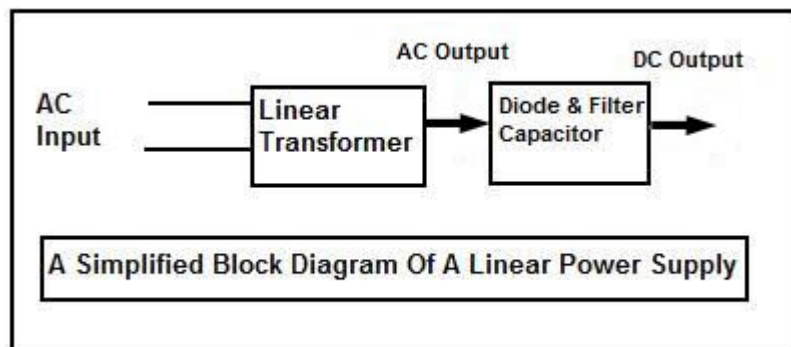
**Figure 3.3- A Typical CRT Monitor SMPS That Do Not Use Optoisolator IC**



**Figure 3.4- A Typical LCD Monitor SMPS Where The Power FET Already Integrated Into The Power IC**

Although there are some differences between the designs of SMPS, they basically still operate base on the same principle. Please turn to the next chapter to read the full SMPS circuits operation in details.

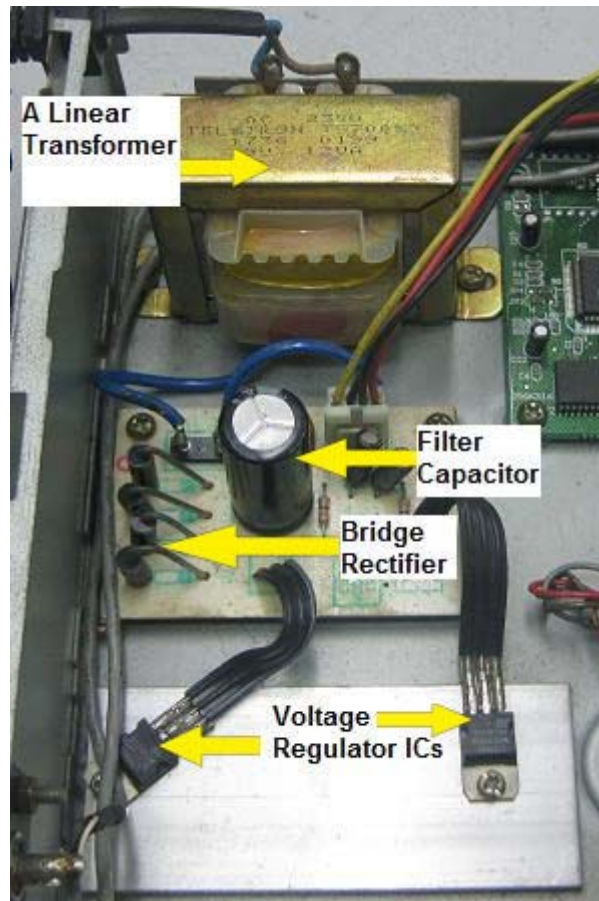
## Linear Power Supply



**Figure 3.5- A Simplified Block Diagram Of A Linear Power Supply**

Linear Power Supply is not covered in this book but anyway I will briefly explain how this power supply works.

AC voltage enters to the primary side of linear transformer and then converts the AC into a lower or higher AC voltage depending on the secondary winding. The output AC voltage is then rectified and filtered by a diode and capacitors to produce a clean DC voltage.



**Figure 3.6- A Linear Power Supply Circuit In A VCD Player**

The linear power supply could have more than one DC output. If there is a problem in the linear transformer circuit, I can say that it is very easy to locate the fault because it is quite direct. Simply use a multimeter to test on the output of the linear transformer (AC voltage) or the DC output (after the diode) to determine the fault fast. This is somehow different in the case of a switch mode power supply. Please read on as the information in the following chapters will eventually guide you to become a professional in repairing SMPS.

If you want to be an expert in power supply repair, **one has to practice, read and fully understand how basic electronic components and**

**power supply work.** With all these knowledge in your mind and hand, **I believe there will be no power supply problems that are too difficult for you to repair.**

## **4) Easy Way To Understand The 11 Circuits Functions of SMPS With The Help Of Schematic Diagrams**

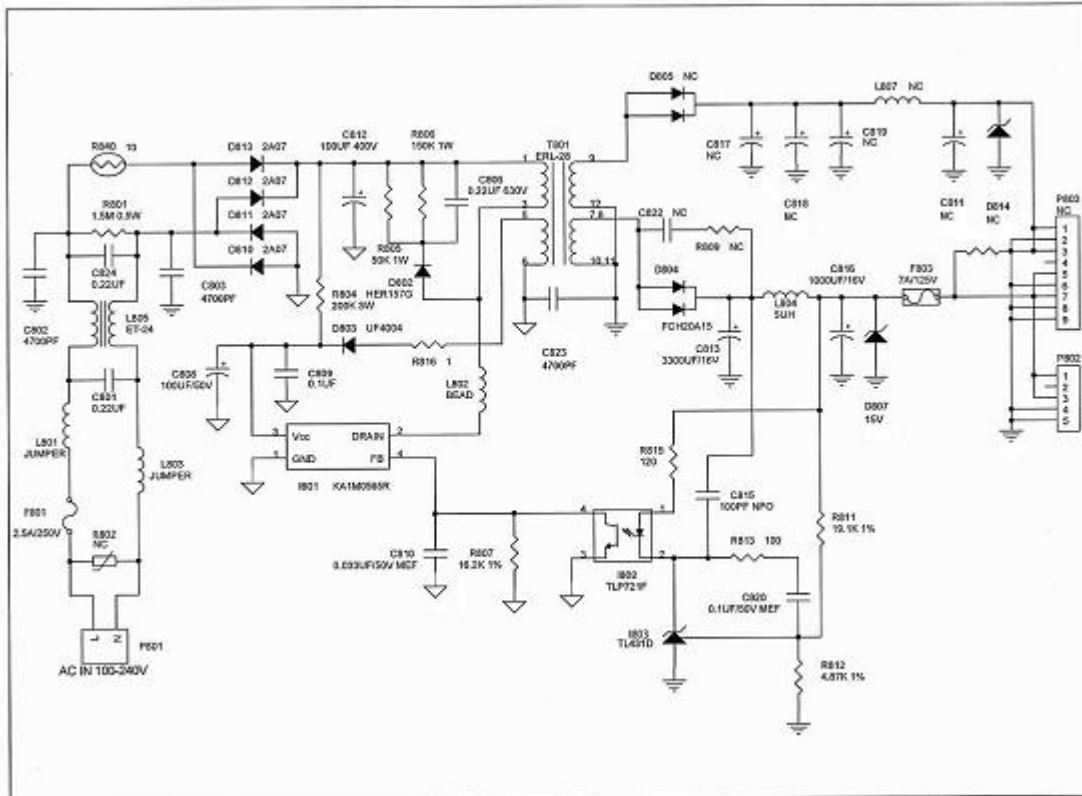
There are many types of SMPS in the market and it is impossible for me to explain all of them. The main point here is to guide you with the help of a SMPS schematic diagram, so that once you have understood how each circuit functions in the SMPS then there will be no problem in repairing all types of SMPS. Many SMPS in the market are quite the same, except that some use more components while others use fewer components. Some SMPS designs are larger while some are smaller. Some use a single power IC to drive switch mode transformer while others use either power FET or bipolar transistor to drive the switch mode transformer and so on. Let me put it in a simple explanation **“Once you know the principle you will know the rest”**. That means it is not necessary for you to understand all SMPS designs in the market in order for you to troubleshoot and repair them.

Generally SMPS consists of about 11 main circuits in order to form the complete set (circuit). Either one of the circuits malfunction could cause problems in SMPS. The 11 main circuits are:

- 1. Input Protection and EMI Filtering Circuit**
- 2. Bridge circuit**
- 3. Start up and Run DC circuit**
- 4. Oscillator circuit**
- 5. Secondary Output Voltage circuit**
- 6. Sampling circuit**
- 7. Error Detection**
- 8. Feedback circuit**
- 9. Protection circuit and**
- 10. Standby circuit**
- 11. Power Factor Correction (PFC) Circuit**

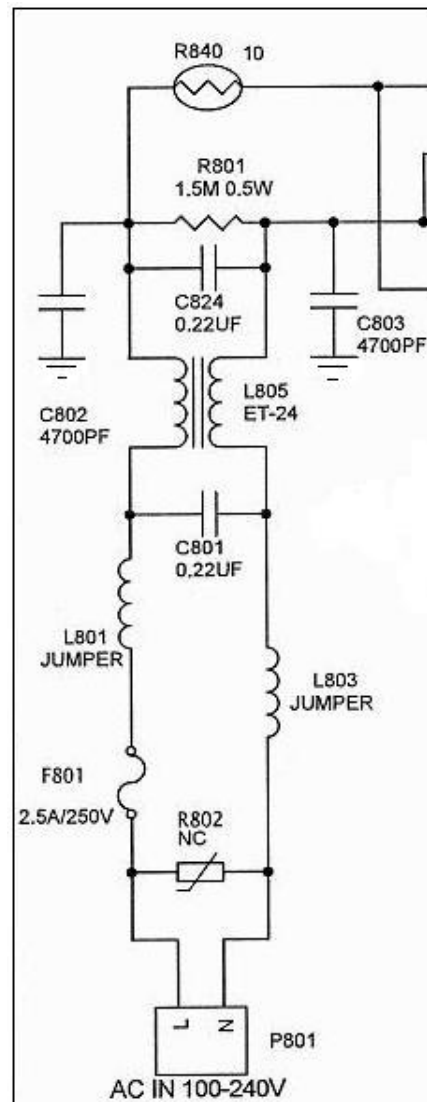
In this topic, I have used the **LCD Monitor SMPS and some other equipment schematic diagrams** as a guide to easily explain how each of these circuits function and **possible causes if they break down**.





**Figure 4.1- A Typical LCD Monitor SMPS Schematic Diagram**

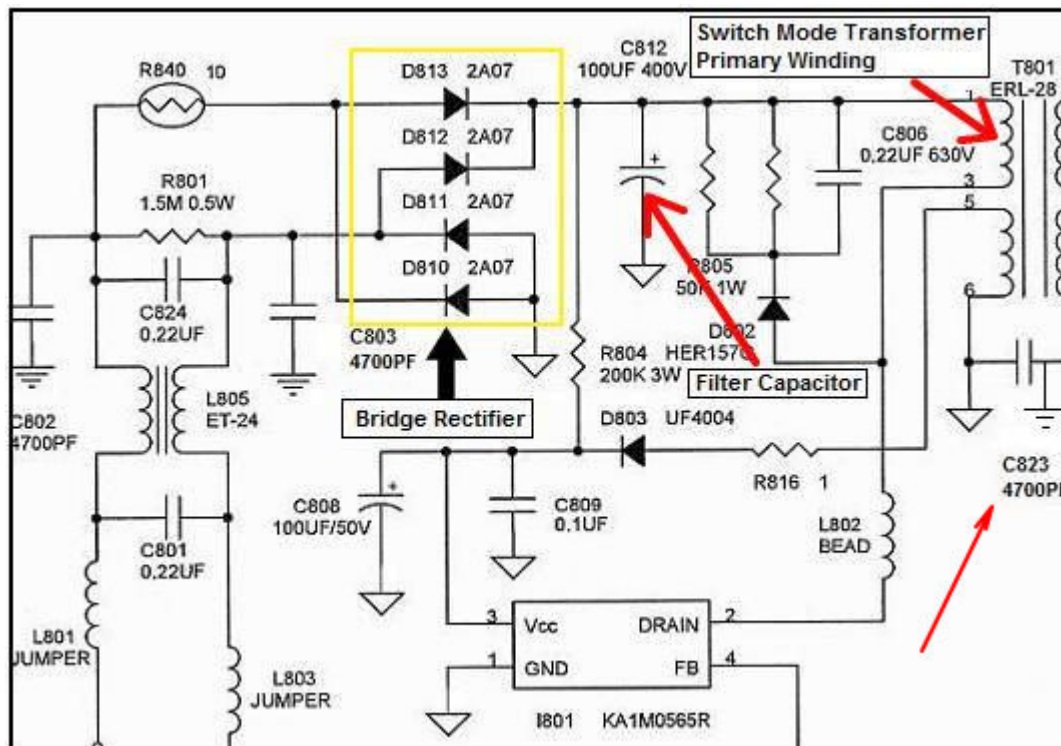
#### 4.1) Input Protection and EMI Filtering Circuit



**Figure 4.2- Input Protection and EMI Filtering Circuit**

This is the first circuit where AC supply enters the SMPS. The Varistor R802 protects the power supply from transient voltages resulting from lightning strikes or power surge. The fuse F801 provides protection against circuit faults and effectively isolates the circuit from the AC supply source. Capacitor C801 and C824 are X capacitors and help to reduce the differential mode EMI. Resistor R801 discharges C801 and C824 on AC removal, preventing potential user shock. Inductor L805 is a common mode inductor and helps in filtering common mode EMI from coupling back to the AC source. C802 and C803 are Y capacitors connected from the Line/Neutral to Earth to reduce common mode EMI. Thermistor R840 limits the **initial peak inrush current** drawn by the circuit at start up.

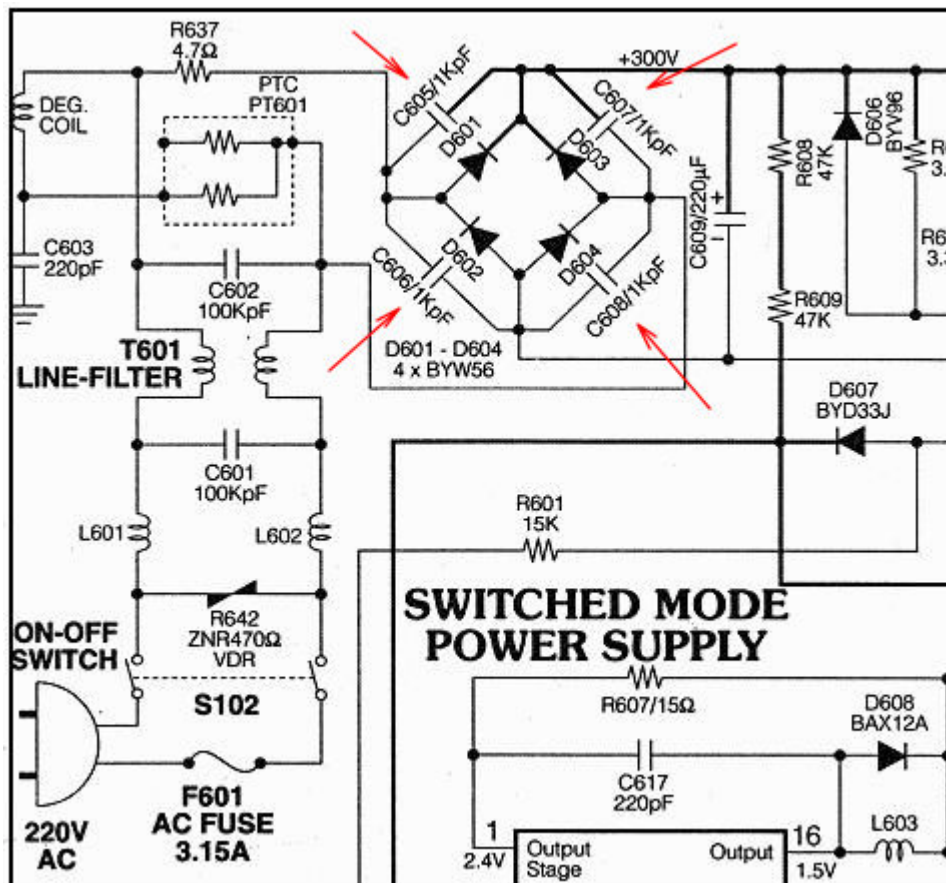
## 4.2) The Bridge Circuit



**Figure 4.3- The Bridge circuit**

The bridge circuit consists of a bridge rectifier (either 4 individual diodes or a single package rectifier) and a filter capacitor. The function of the bridge rectifier is to convert the incoming AC voltage into DC voltage and the filter capacitor (usually have the value of 220uf 400Volt) to remove the ripples and this will provide a nice DC voltage source to the primary winding of switch mode power transformer. For countries that use the 220 to 240 VAC, the DC voltage that you will get is about 300VDC and for countries that use 110-120VAC, the DC voltage that you will get is about 150 to 160 VDC. The DC voltage that you get is measured across the two pins of the filter capacitor using a multimeter. You may refer to chapter 11 on “**How to easily perform voltage testing on SMPS circuit**”.

In some power supply design, you could see that there are capacitors connected across each diode in the bridge rectifier as seen from figure 4.4. The function of the capacitors is to suppress the RFI signals generated by the rectifier diodes.



**Figure 4.4- Capacitors Connected Across Each Diode In The Bridge Rectifier**

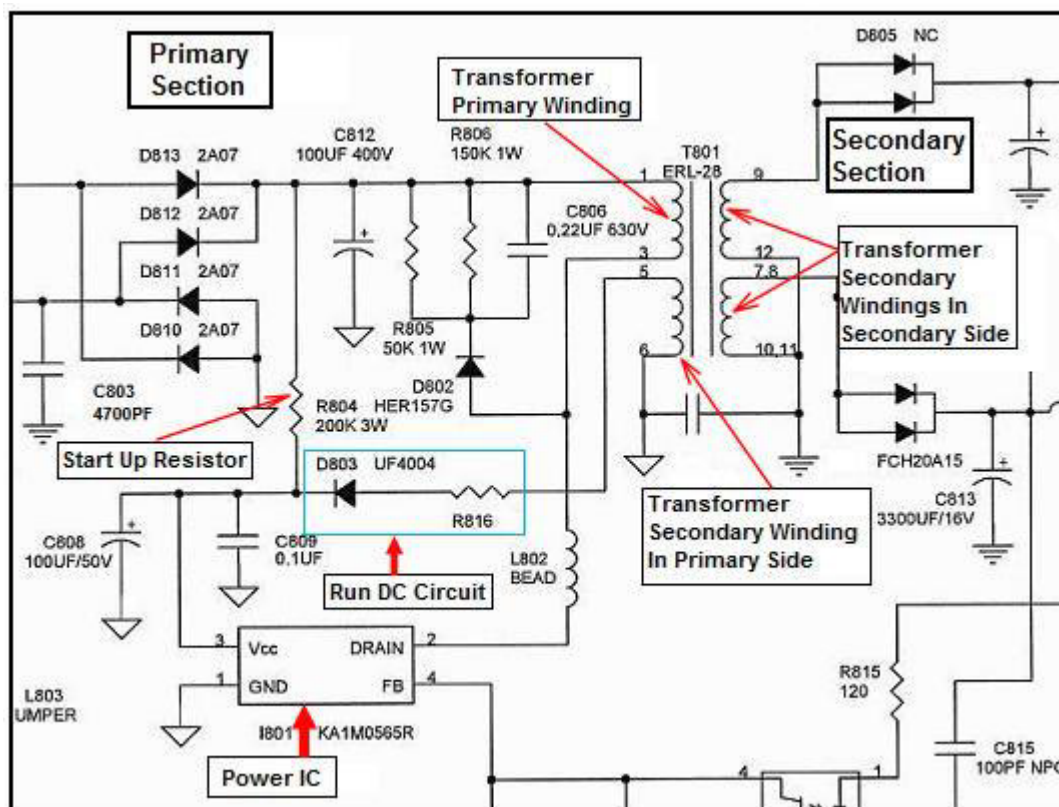
Asymmetrical mains pollution is reduced by the insertion of C823 (figure 4.3) between primary ground (hot side) and secondary ground (cold site) of the power supply. This component (capacitor) sometimes could be found parallel with another resistor which is required to satisfy the main isolation requirements.

If the bridge rectifier is shorted, then the main fuse would surely blow. In some cases, it could also cause the power IC, power FET and corresponding components to blow as well. If the filter capacitor value drops, open circuit or the ESR value had gone high, it may cause no power symptom, power blink or unstable voltage in the secondary side. If you are repairing CRT Monitor/TV, you would notice that the display at both the right and left sides have “Waves” swimming across the screen vertically.

### 4.3) Start Up and Run DC Circuit

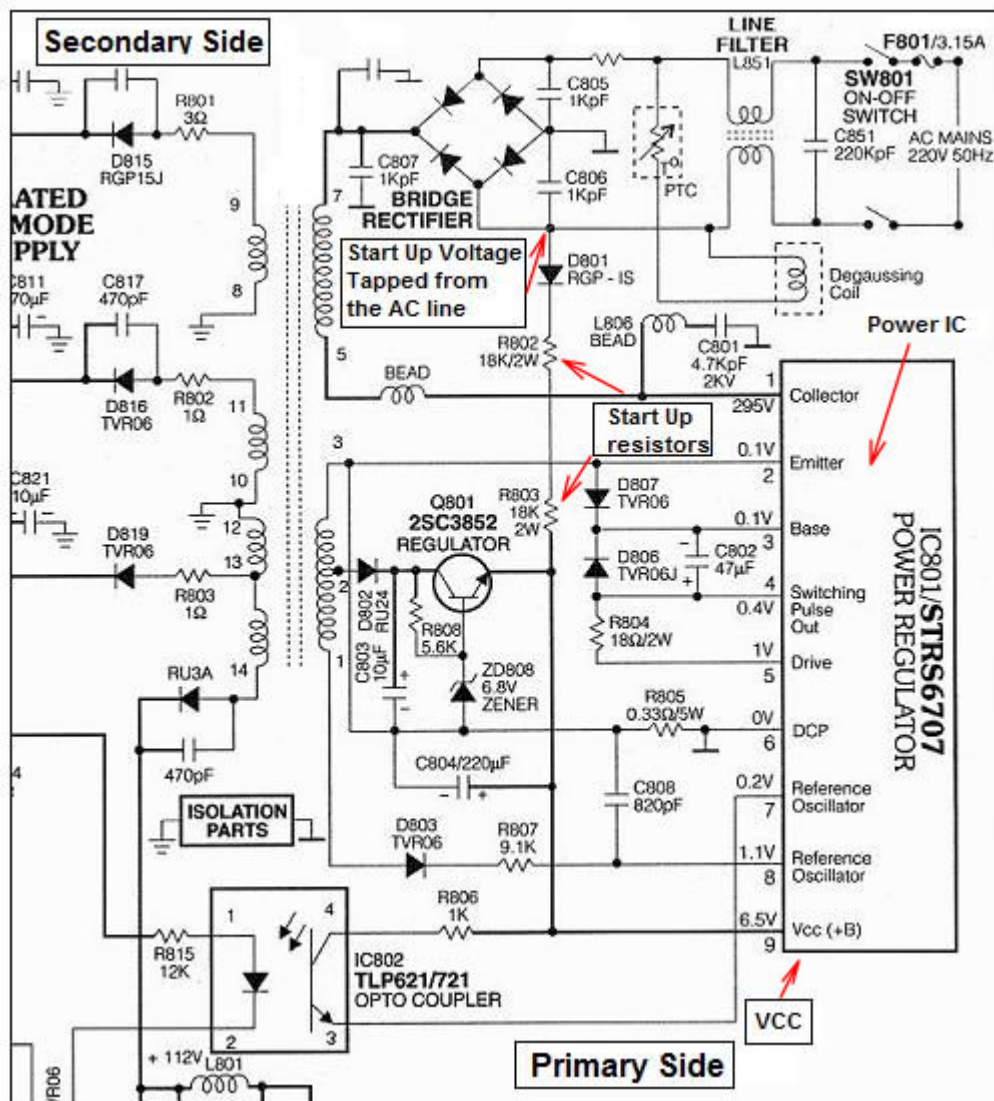
This circuit usually consists of one to three high Ohms resistors (usually from 47K Ohm to several hundred K Ohm) and is connected between the 300VDC voltage line and the supply input of power IC. After the 300 VDC goes through the start up resistors, the voltage will drop to about 16 VDC (start up voltage depends on the type of SMPS design) and this voltage is use to kick on the oscillator in the power IC the first time.

After the kick starts, even if the start up resistors have been removed, the supply will continue to operate because it now gets the supply from another source which is the secondary winding (in the primary side) as seen in figure 4.5. This is called the **Run DC circuit**. As the large filter capacitor discharges the power IC requires additional voltage to maintain stable operation thus additional circuit, i.e. Run DC circuit is provided to the power IC from the secondary winding so that the circuit (voltage source) becomes stable. It consists of a resistor (R816) to prevent peak rectification of spikes, a diode (D803), to rectify the incoming signal from the transformer which is then smoothed by C808 to give a DC level.



**Figure 4.5- Start Up And Run DC Circuit**

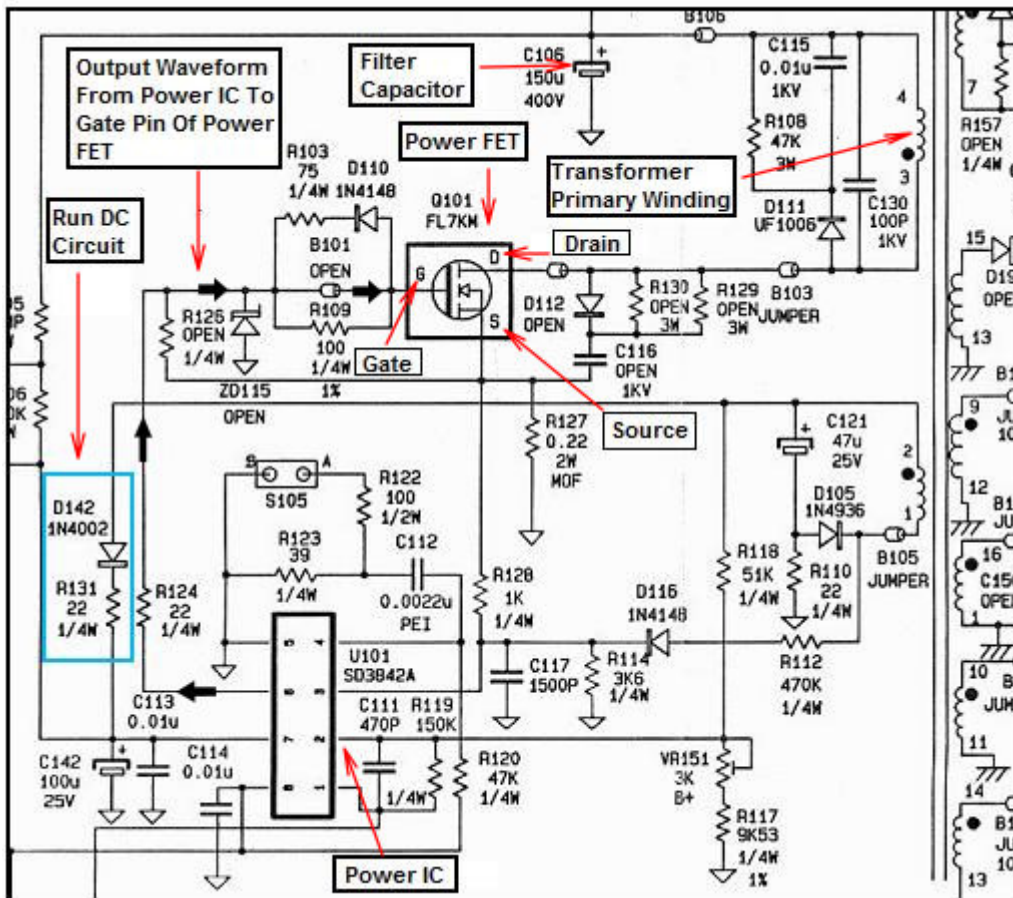
**Note: In some designs, the start up voltage is not derived from the 300VDC source itself, but from one of the AC line as seen from figure 4.6**



**Figure 4.6- Start Up Voltage Derived From One Of The AC Pin Of Bridge Rectifier**

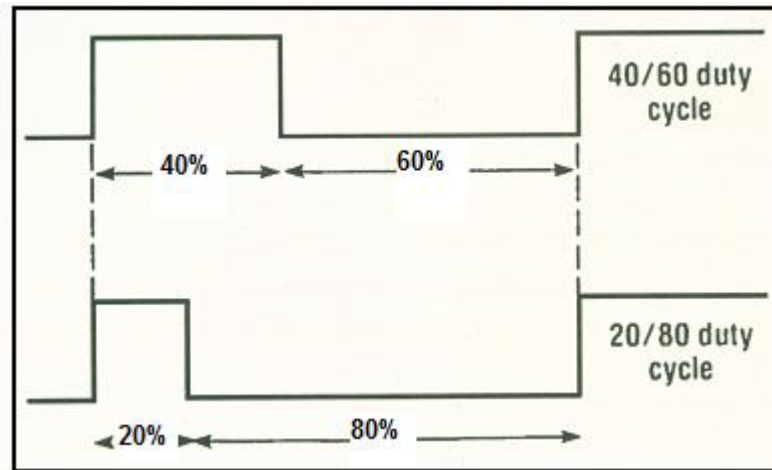
If the start up resistors is opened circuit or turned into high ohms, it would cause no power symptoms. Sometimes it could also cause intermittent power problem. That means sometimes you can turn on the SMPS but after you have switched off the supply and turned it on again, it would not work. Wait for a while and try a few more times, the SMPS will then begin to start again. This is what I called as intermittent no power problem.

#### 4.4) Oscillator Circuit



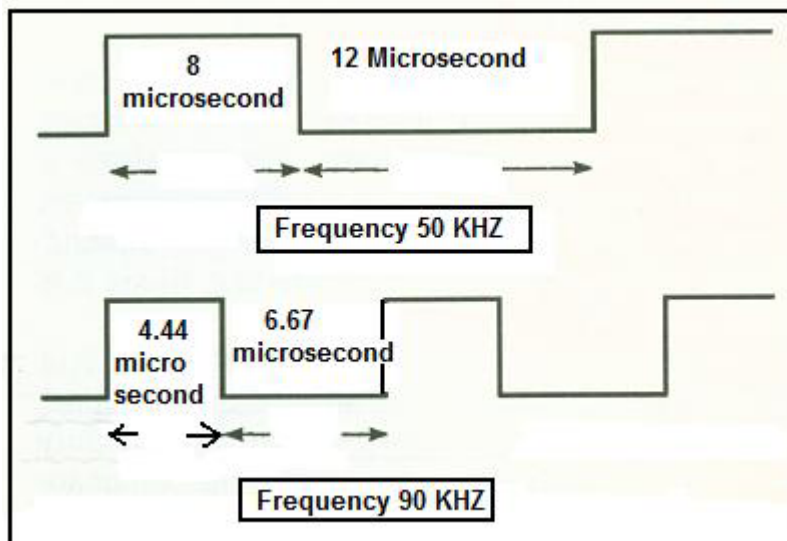
**Figure 4.7– A 15” CRT Monitor SMPS Oscillator Circuit**

This circuit consists of power IC U01, power FET Q101 (or power bipolar transistor), the transformer primary winding and at least one secondary feedback either from secondary winding or from optoisolator IC. The power IC is the main source in controlling the output voltages at the secondary side of SMPS. The power IC generates output pulse waveform (**drive signal**) to the power FET through the gate pin and the power FET started to switch on. When the switch is turned “On”, the transformer primary winding charges (energy stored) and when the switch is turned off, the energy in the primary winding will be transferred (discharges its stored energy) into the secondary. **In other words, switching the primary winding of the transformer “On” and “Off” will result in secondary voltage.** This also shows that by controlling the switch’s on/off time (from the power IC) we can obtain necessary secondary voltage. In other words, the output voltage can be varied by changing the frequency or duty cycle of the FET (or bipolar transistor) drive signal (waveform) as seen in figure 4.8 and 4.9.



**Figure 4.8- Duty Cycle Of The Pulses**

The transistor (FET or bipolar transistor) conduction time (to determine the output voltage at secondary side) can be changed by varying the width of the pulses as shown in figure 4.8.



**Figure 4.9- The Frequency Of The Pulses**

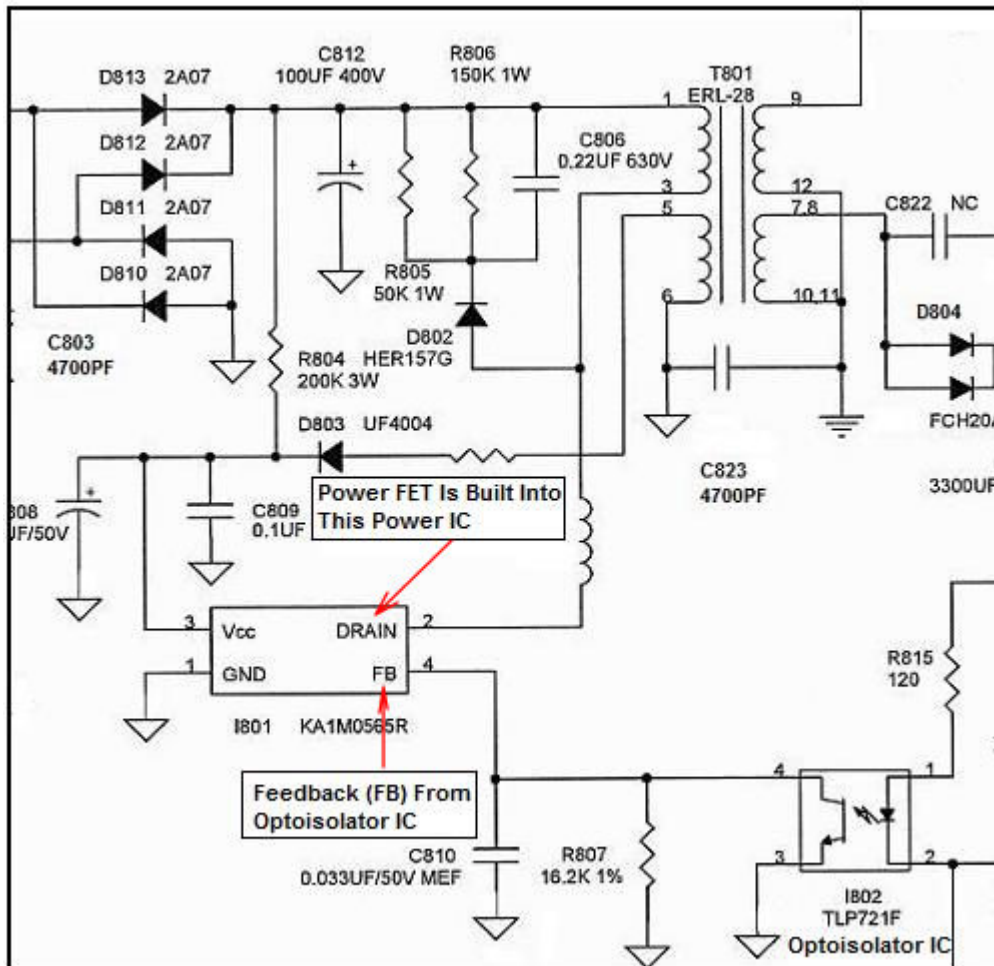
The transistor (FET or bipolar transistor) conduction time (to determine the output voltage at secondary side) can be changed by varying the frequency of the pulses as shown in figure 4.9.

Note: When the FET turns off, the leakage inductance of the transformer induces a voltage spike on the drain node. In order to protect the power FET Q101 against (inductive) spikes from the transformer primary and to reduce ringing, components R108, C115 and D111 are placed in the circuit (refer to figure 4.7). The amplitude of that spike is now limited by



this RCD (Resistor, Capacitor and Diode) clamp network. These parts are less likely to fail than the other components in the power supply.

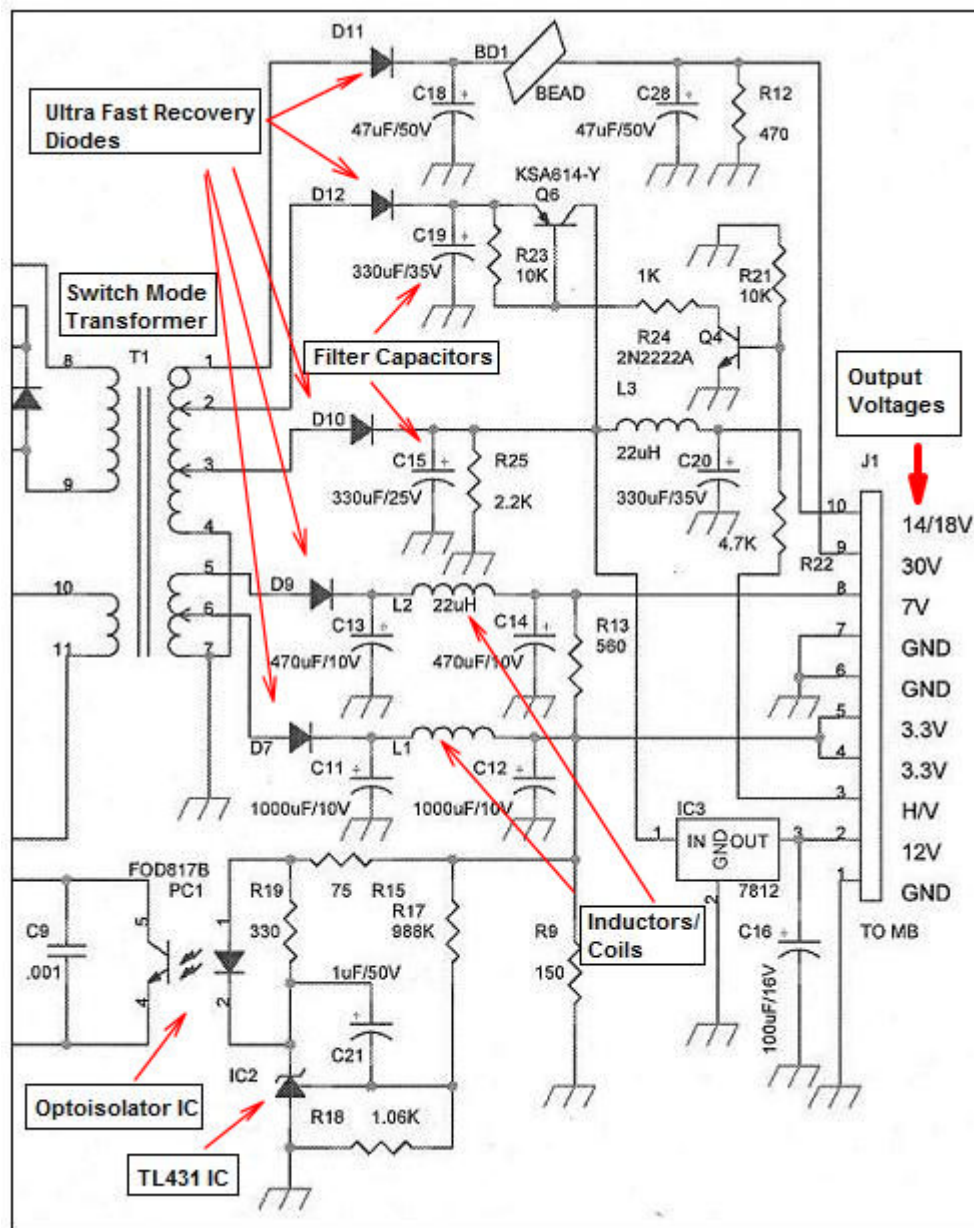
By the way here is the schematic diagram of the **power FET integrated into power IC**. Basically the operation is the same as in figure 4.7.



**Figure 4.10– A LCD Monitor SMPS Oscillator circuit**

If the power IC is shorted (no output waveform produced), primary winding of transformer shorted, power FET open/shorted or even the corresponding components related to this oscillator circuit have problems, it would cause the SMPS to stop functioning. In some cases, it might even blow the Main fuse.

#### 4.5) Secondary Output Voltage Circuit

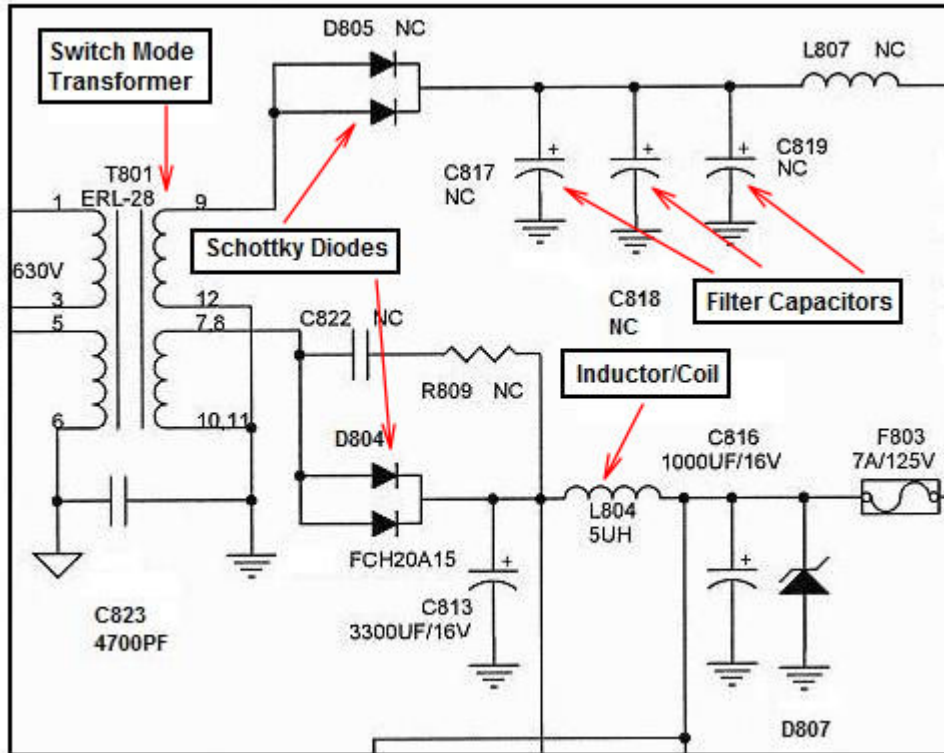


**Figure 4.11– A Typical Satellite Receiver SMPS Secondary Side**

The secondary output voltage circuit provides various positive or negative DC output voltages to other circuits like Vertical, Horizontal, CPU, Color, Flyback transformer, Computer Motherboard and etc. The secondary output voltage circuits usually consist of diodes (ultra fast recovery diodes-to convert AC to DC), filter capacitors (generally are electrolytic capacitors-to filter off the ripples) and inductors/coils (a coil allows DC to flow through it while restricting AC current flow). With these three components in each of the output line, the outputs generated are clean DC and suitable for various circuits (loads). The amount of

voltage generated in each output depends on the total turns in each of the secondary winding of switch mode transformer. The more turns it has, the higher output would be generated.

**Note:** In some SMPS designs, instead of using ultra fast recovery diodes to convert AC voltage to DC, manufacturer uses Schottky diodes for better efficiency as seen D804 and D805 in figure 4.12.



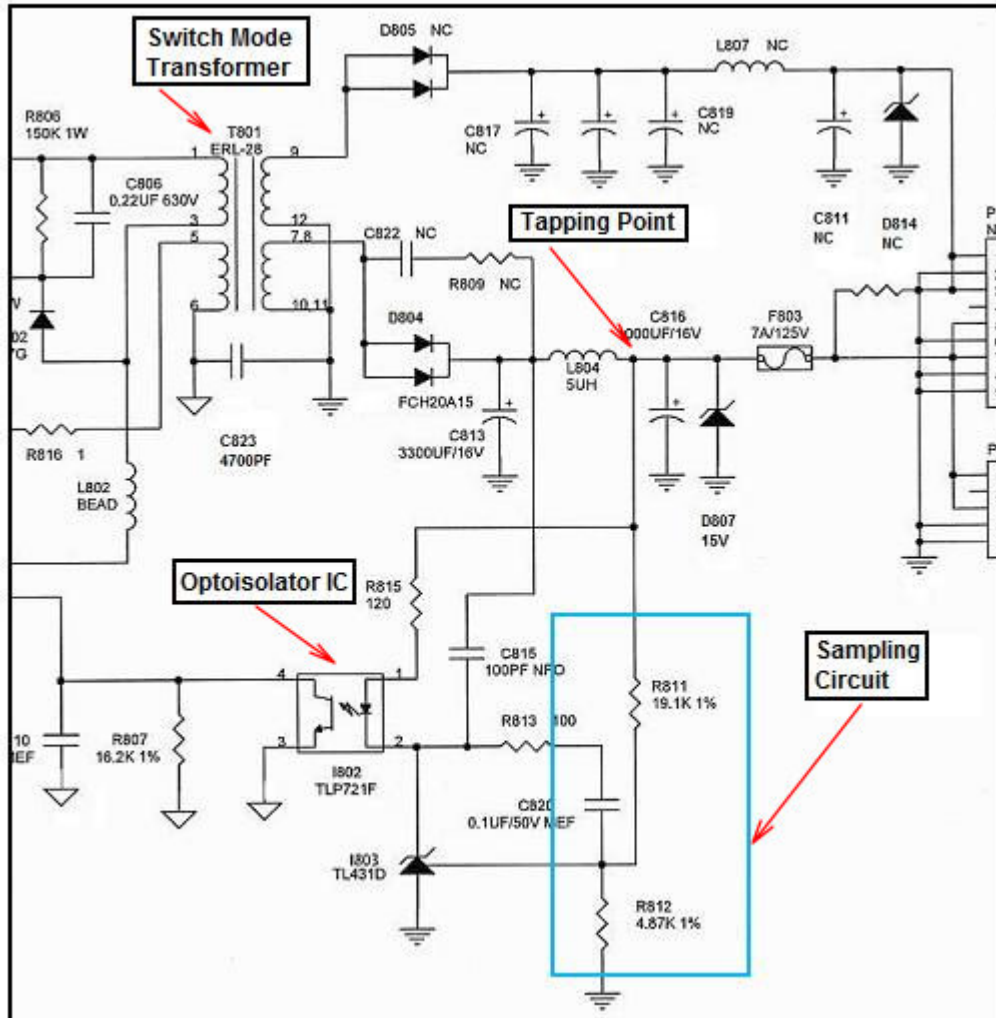
**Figure 4.12- Schottky Diodes In LCD Monitor SMPS**

In figure 4.12, D804 provides output rectification. Low ESR capacitor C813 provides filtering. Inductor L804 and capacitor C816 form a second stage filter that significantly attenuates the switching ripple across C813 and ensure a low ripple output. Snubber networks comprising R809 and C822 damp high frequency ringing across diode D804, which result from leakage inductance of the transformer windings and the secondary trace inductances.

If either a diode shorted or leaky or the capacitor has high ESR value, it would cause the SMPS to blink/cycle and sometimes no power too. The output voltages may drop and be unstable, causing problem to the respective circuit or the whole circuit. For example, if the heater/filament voltage line in the CRT Monitor has a bad filter capacitor, it would cause

the line voltage of 6.3 Volt DC to drop to about 2 to 3 volts causing no display or dim display symptom.

#### 4.6) Sampling Circuit



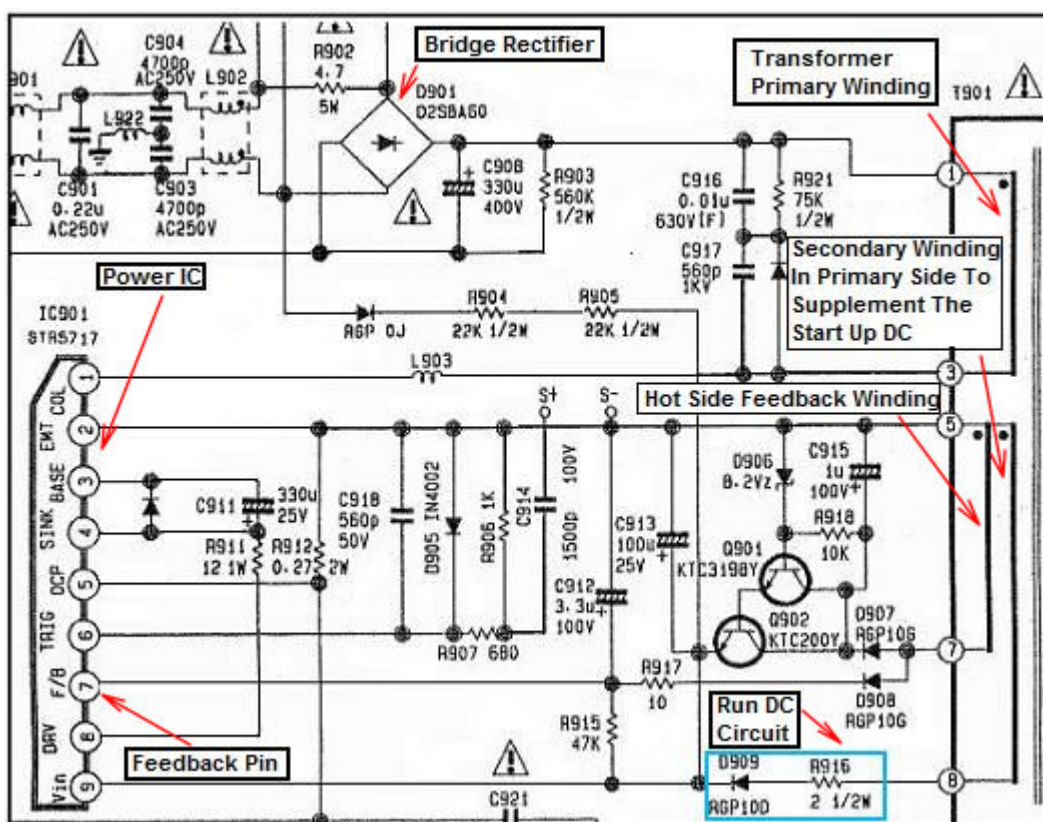
**Figure 4.13- A Typical Sampling Circuit From LCD Monitor SMPS**

In order to maintain the output voltages delivered to the load (various circuits), a sample of at least one output voltage source developed by the supply is required. For a CRT Monitor power supply, the sample voltage normally derived from the B+ voltage line that goes to the primary winding of Flyback transformer. Some call this sampling circuit as **sensing** circuit.

Normally only one output voltage source is required to be sampled, because if the particular output voltage source is too low or too high, generally all of the other output voltages may vary too. **The reason for this sampling circuit in SMPS is to provide an input to the error**

detection/feedback circuit so that the duty cycle in the primary side can be controlled and effectively maintain the output power. The sampling circuit usually consists of only a few resistors and in some designs, a preset could be found. If this circuit has an open/resistor or resistor turned into high ohms or even open circuit in the preset/trimmer the power could blink and also there might be a power shutdown due to output voltages being too high.

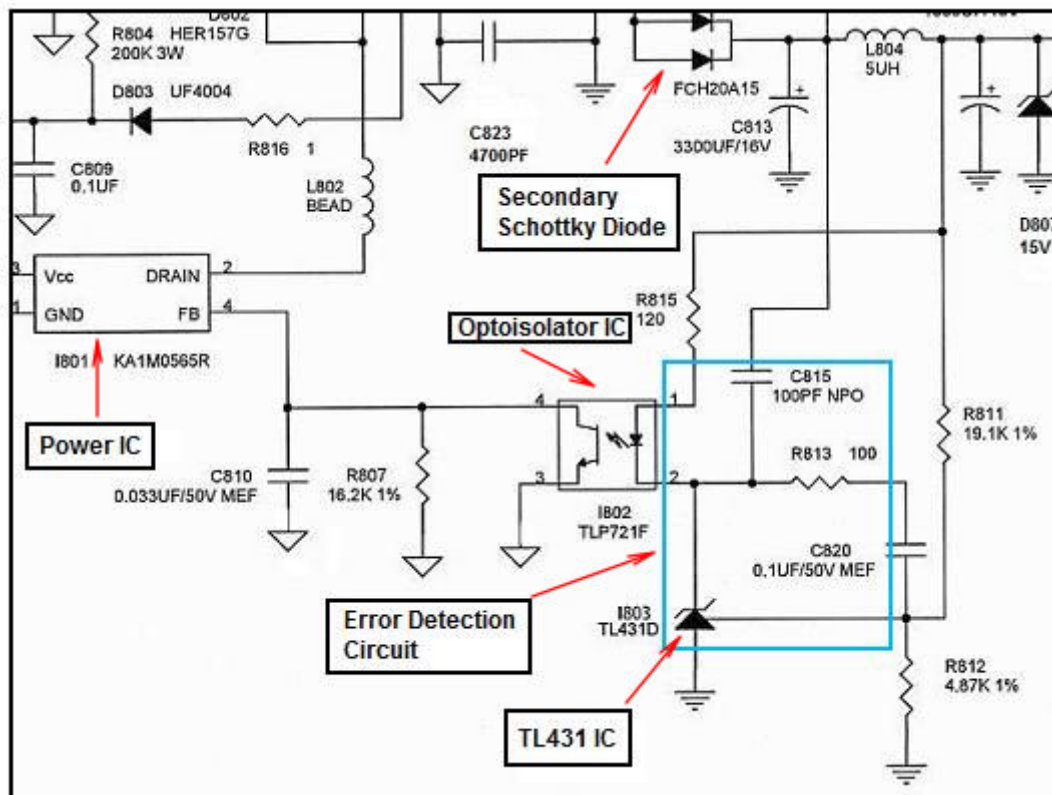
**Note:** In some SMPS designs, the sample voltage was taken from the hot side (primary side) feedback winding to provide a signal to the power IC in order to control the power level delivered to the load as shown in figure 4.14.



**Figure 4.14- The Sample Voltage Taken From Primary Side Because This SMPS Design Does Not Use Optoisolator IC As Feedback**

Please observe the Power IC (IC901) pin number 7 written as F/B which means feedback. Tracing backward from this pin, it will lead you to the feedback winding at pin 7 of T901.

#### 4.7) Error Detection/Error Amp Circuit



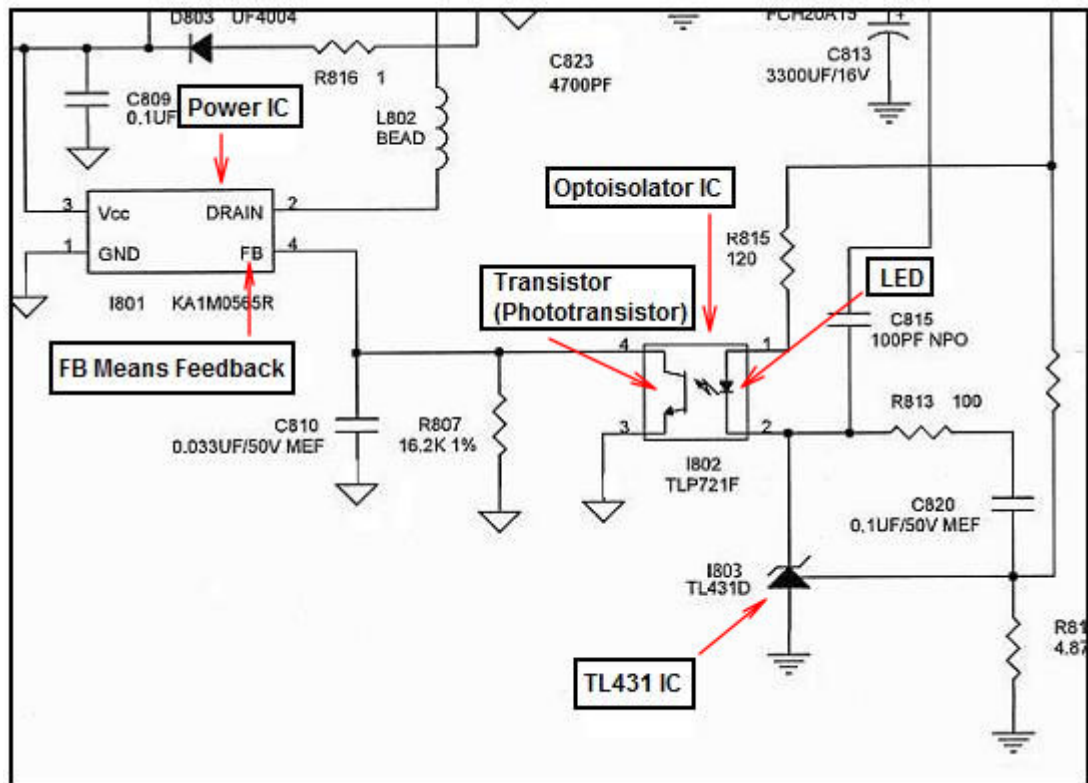
**Figure 4.15- The Error Detection/Error Amp Circuit In LCD Monitor SMPS**

Basically this error detection circuit consists of one IC with the part number of TL431 (**it can be other part number-depends on SMPS designs**). TL431 is an adjustable precision shunt regulator IC and in some SMPS designs you could notice there are also few components around this circuit.

The error detection circuit monitors the sampled voltage source (increases or decreases its level) derived from the sampling circuit and **activates** the Optoisolator IC feedback as needed to control the “On” time of the switching supply so that it will not deliver more or less power to the secondary side.

If this IC or corresponding components have problem, it will cause power shutdown, power blinking, low output power and even totally no power at all.

#### 4.8) Feedback Circuit



**Figure 4.16- The Feedback Circuit In LCD Monitor SMPS**

This is generally an Optoisolator IC that uses the internal LED to emit lights to the phototransistor. The phototransistor acts as an output device while the LED acts as an input device. The light generated by the LED is determined by the level and potential of the DC error voltage applied to the LED's by the error detection circuit. When the LED is emitting light (inside the Optoisolator IC), the phototransistor is conducting. That means if the LED light intensity is great, the phototransistor will conduct even more and vice versa (decreases and increases its resistance proportionally) thus controlling the input to the oscillator in Power IC (through feedback pin as seen from figure 4.16). The end result causes the oscillator's frequency to change in response to the error signal feedback and alters the drive signal to compensate for the output voltage change. Remember, this comparison/compensation occurs continually and provides a closely regulated output voltage.

**Note:** The feedback circuit also provides isolation between the cold ground (LED) side and the hot ground (phototransistor) side of the power supply. In some designs, the error signal feedback is developed

from the hot side secondary winding of the power supply and requires no isolation as seen from figure 4.14.

If the Optoisolator IC have problems like an open LED or a shorted/leaky phototransistor, the power supply would blink, or produce lower voltage or even shutdown after the power supply is turned “On”.

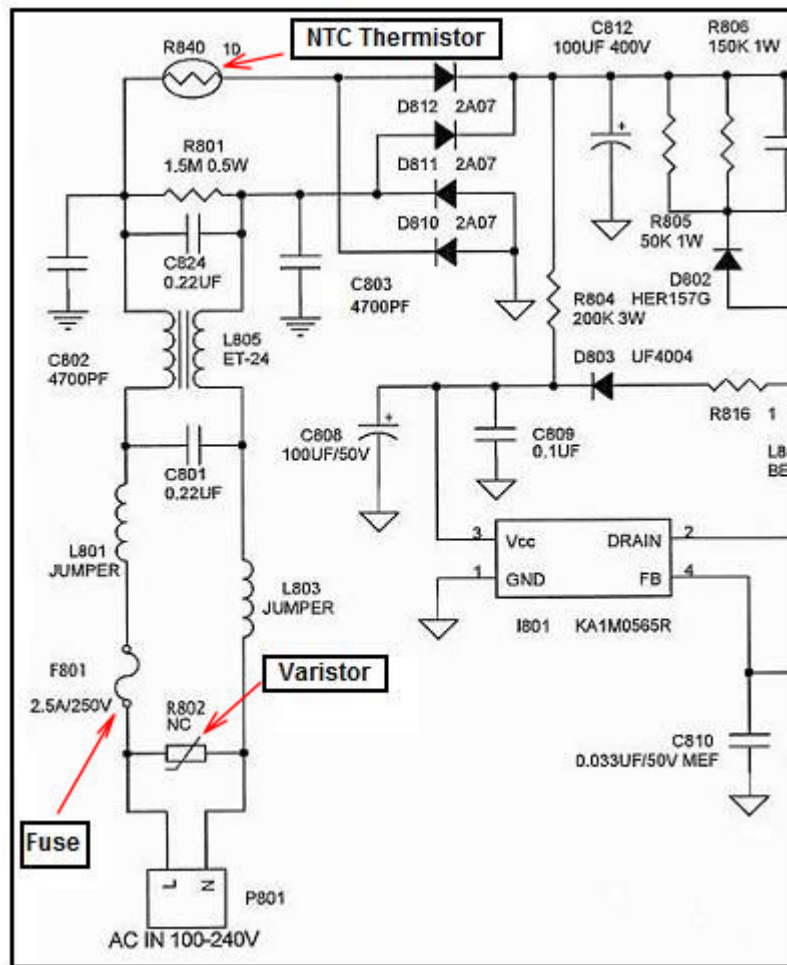
**Note:** The Sampling, Error Detection and Feedback circuits are called the regulation circuit. The primary sensing (hot side feedback-figure 4.14) is cheaper but the output regulation is less accurate. It is used especially for the low end market (low power, low budget). Secondary sensing (the regulation circuit) is more expensive but has a **higher performance**. It is used especially in the medium and high end market.

#### **4.9) The Protection Circuit**

Do you know that SMPS has one or more protection circuit? The protection circuit is designed to protect the components by shutting down either part or all of the power supply in the event problem occurs. There are four common types of protection circuits that can be used by SMPS designers for circuit protection against the following dangerous conditions. They are Surge Protection (SP), Over voltage protection (OVP), Over current protection (OCP) and Thermal Shut Down protection (TSDP).



## A) Surge Protection (SP)



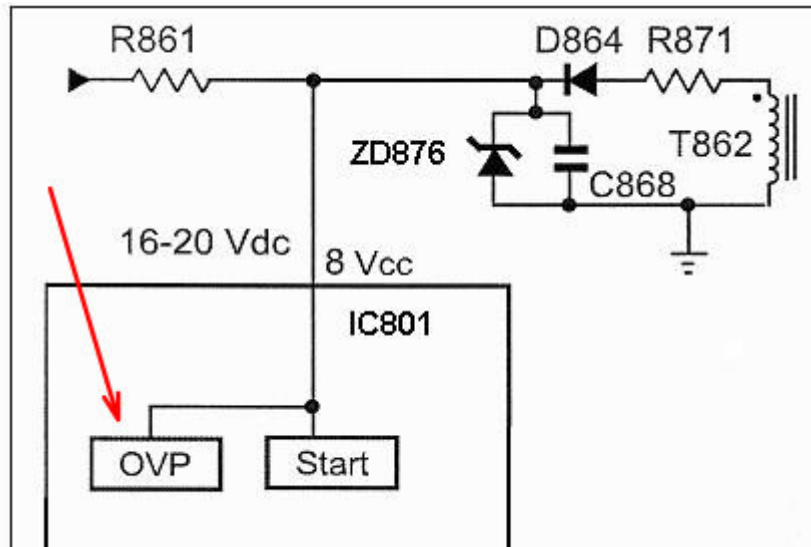
**Figure 4.17- A Typical Surge Protection Circuit In LCD Monitor SMPS**

Basically the main surge protection components are the **Fuse**, **Varistor** and the **NTC Thermistor**. The full explanation of these components can be found in chapter 5 (Electronic Components Found In SMPS and Possible Causes).

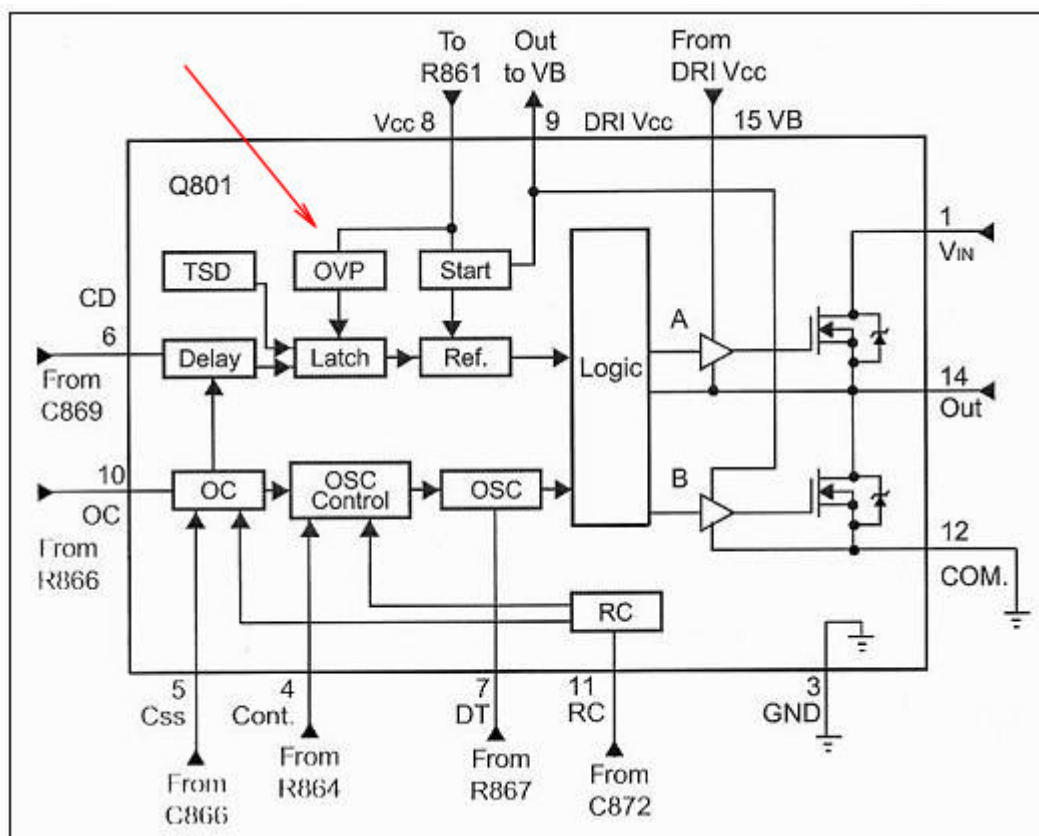
## B) Over Voltage Protection (OVP)

The function of the OVP circuit is to monitor the start up DC supplied to the power IC. If the designers did not place this OVP circuit in the primary side, then they will definitely design at least one in the secondary side. It senses the over voltage conditions and shut down the power supply if they occur. Once it is shut down, you need to remove the AC main and replug to get it turn on again.

The OVP circuit can be build inside the Power IC (built in) or it can be in external circuit.



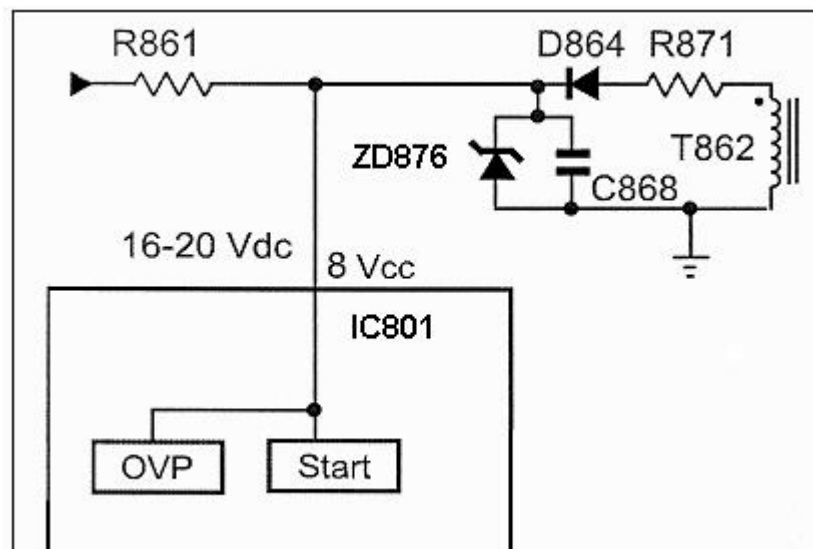
**Figure 4.18- Built In OVP Circuit In Power IC STRZ4117**



**Figure 4.19- Internal Schematic Of Power IC STRZ4117**

If you look at figure 4.19, you could see the OVP block (inside the block is the OVP circuit) is connected to a latch block and the start block. This is how the circuit works. This Power IC requires a start up voltage of about 16 to 20 VDC to work and the voltage was tapped from the 300 VDC line through resistor R861. The limitation of the start up circuit is that the voltage developed tends to fluctuate with the switching frequency of the power supply. Due to this problem, **the Run DC circuit was developed so that the voltage source to the Power IC becomes stable (refer to page 29)**. The Run DC circuit voltage source was derived from the secondary winding (T862) in the primary side when the primary winding of the transformer was energized.

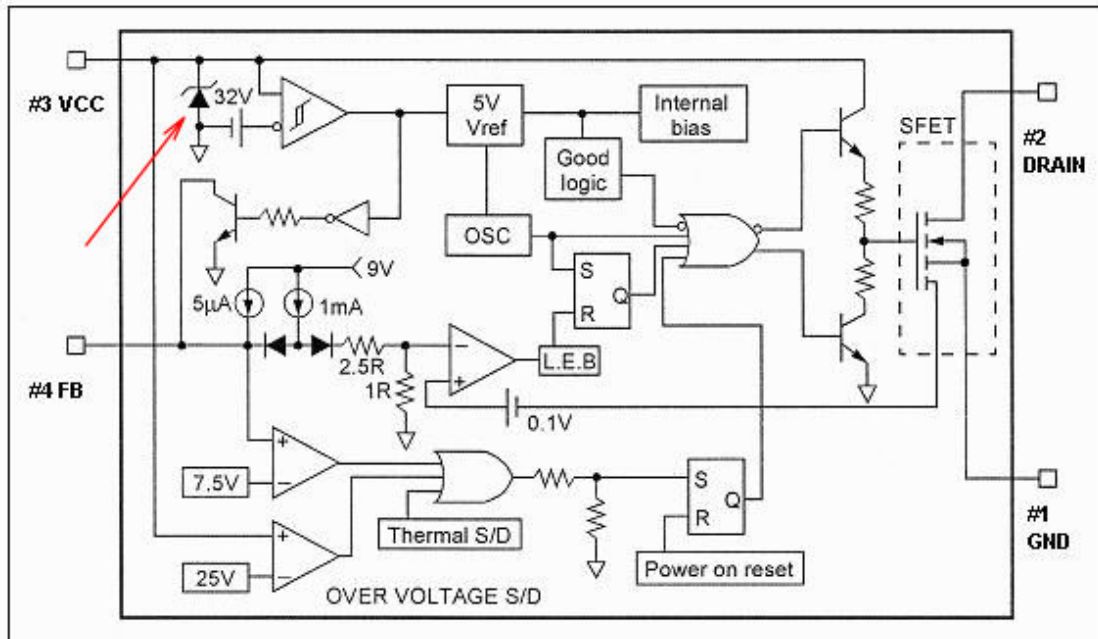
If the voltage source to Pin 8 of Power IC STRZ4117 increases to more than 25 volt, the internal OVP circuit will sense the overvoltage and triggers the latch and the switching stops. If the power supply has already shutdown, you will need to power Off the SMPS and turn it on again in order to restart the power supply.



**Figure 4.20- External OVP Circuit**

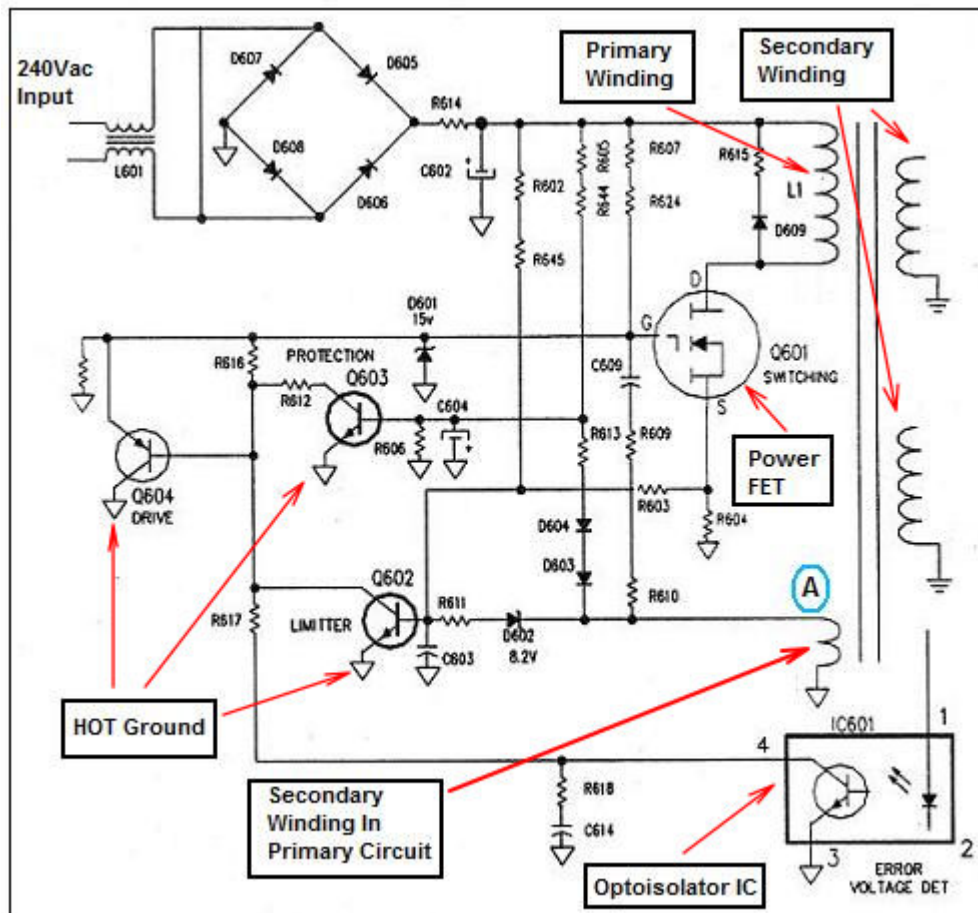
Refer to figure 4.20 and you could see that the ZD876 is a 27 Volt zener diode that protects the power IC by preventing the **excess voltage** of more than 27 Volt increases on pin 8 of the power IC (IC801). This is how the circuit works. If more than 27 volt across the zener diode, the zener diode will conduct to ground and this would cause the start up voltage to **drop to zero volt** and thus shutting down the power IC. If the excess voltage happens for a long period, the zener diode would go short circuit and may blow up the power section components. However, if the

excess voltage happens only for a split second, the power supply would shut down and as usual you need to turn off the SMPS and restart it. In some Power IC design like the KA1M0565R the zener diode is integrated into the IC.



**Figure 4.21- Internal Block Diagram Of Power IC KA1M0565R**

Figure 4.22 in the next page shows another external OVP circuit in the primary side

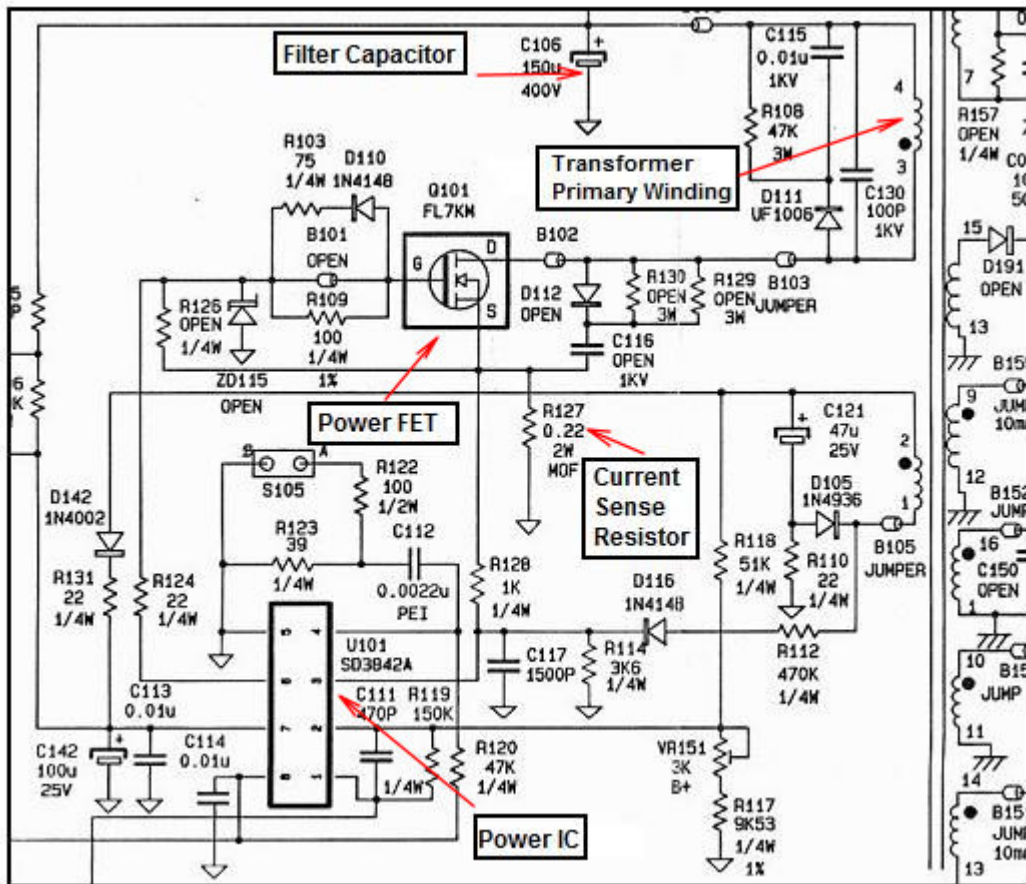


**Figure 4.22- External OVP circuit**

The winding labelled as “A” is a feedback secondary winding in primary side. The protection circuit of this circuit are R611, zener diode 8.2 Volt (D602) and the feedback secondary winding. If the voltage produced exceeds 8.2 volt, the zener diode will conduct and this cause Q602 to triggered. Due to now Q602 has very low resistance between collector and emitter (fully turn on), this cause Q604 to fully turn on and cause the power FET to cease operation because the gate signal now is going to ground.

**Note:** Due to lots of SMPS designers in the market, not all use the same over voltage protection (OVP) circuit in each SMPS. The best to understand each of the OVP in SMPS, you must get the SMPS schematic diagram for reference. Remember, some designs can have more than one OVP circuit.

### C) Over Current Protection (OCP)

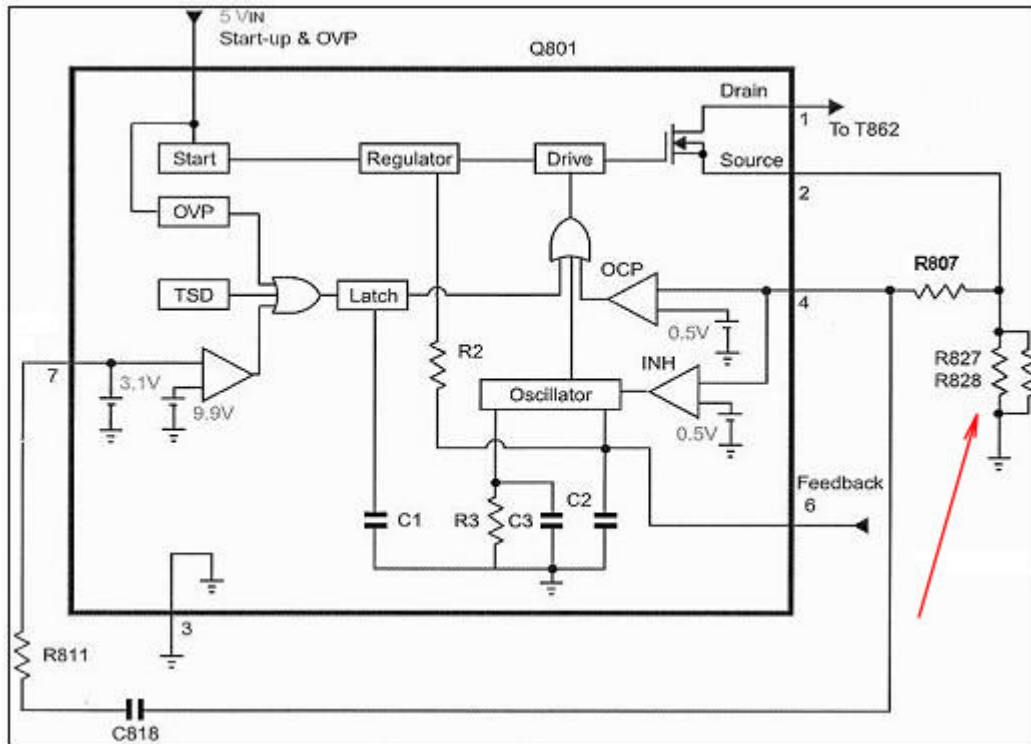


**Figure 4.23- Current Sense Resistor In Primary Side of a CRT Monitor SMPS**

There are many SMPS designs that have the Over current protection circuit in the primary side. This circuit usually samples the voltage drop across a resistor in series with the switching transistor (FET or Bipolar Transistor) if the transistor draws too much current. This resistor is called “Current Sensing Resistor” as seen from figure 4.23. **If the current rises abnormally, the voltage will exceed a reference level and shut down the output waveform** of the power IC thus no output power produced from the secondary side. For your information, the pin 3 of the Power PWM IC (U101 SD3842A or UC3842) is called i-sense which means current sense.

Note: The over current sensing resistor can increase in resistance value and cause a false shutdown. The value may be increased slightly and cause an intermittent shutdown condition. The value is usually very small from 0.1 ohm to about 1 ohm and you can test the exact value

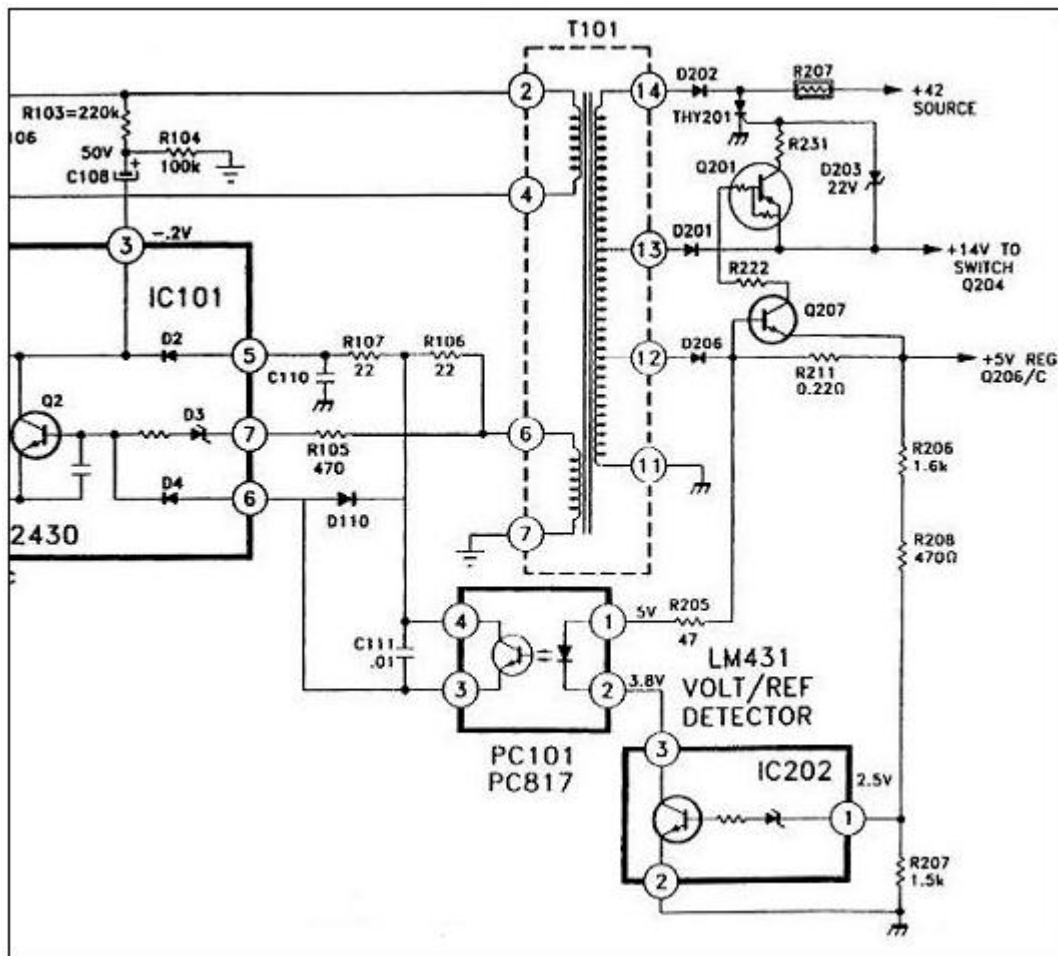
using a Blue ESR meter. For your information the Blue ESR meter has the function to check **very low ohms resistor value**.



**Figure 4.24- Power FET Integrated Into Power IC**

Like the OVP, the OCP circuit can also be found in the power IC as seen from figure 4.24. The function is just the same as in figure 4.23 except that now the Power FET is already integrated into the Power IC (pin 1 and 2). When the Power FET is turned On, current flows through resistors R827 and R828 (current sense resistors) and a voltage develops at the over current protect (OCP) terminal at pin 4. If the voltage reaches 0.5 volt, the internal OCP comparator turns the Power FET Off and stops its current flow.

In some SMPS design the Over current protection (OCP) is located in the secondary side as seen from figure 4.25 in the next page.



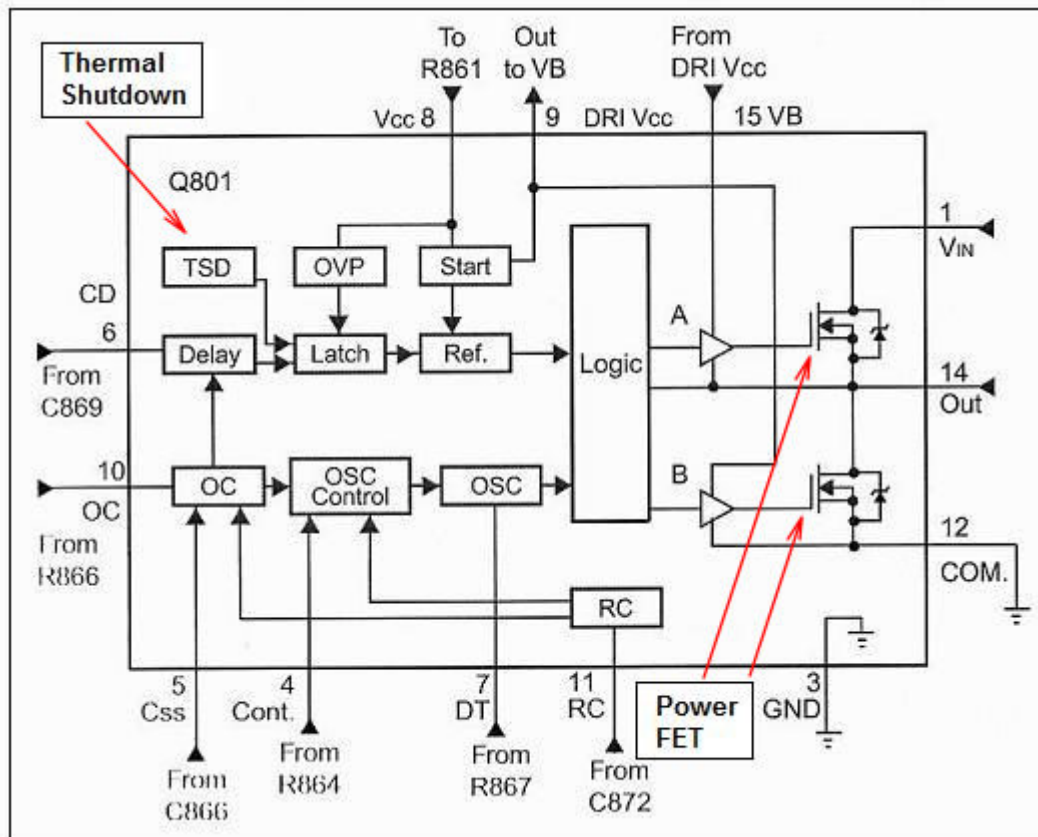
**Figure 4.25- OCP Circuit In Secondary Side**

This circuit is a 5 volt secondary protection. R211 is the key component in this over current shutdown. Excessive current is when 0.6V appears across R211. This is sufficient to turn ON NPN Q207, which turns ON PNP Q201. Q201 in turn forward biases the gate of SCR THY201 and it latches ON, grounding out the 42 volt T101 secondary. This short lowers the Q of the transformer (secondary absorb all the power) and the oscillator stops because of insufficient feedback voltage from T101 pin 6 via PC101, into IC101 pin 6 to sustain oscillation.

Although the SCR resets when no more current flows through it, the oscillator cannot start again. This is because C108 is charged (+=150VDC, -=0VDC) and cannot pass any current to turn Q1 ON. The oscillator will restart when the AC plug is removed.



#### D) Thermal Shut Down Protection (TSD)



**Figure 4.26- Showing The Thermal Shut Down Protection Circuit In The STRZ4117 Power IC**

Because of the amount of current flow through the Power FET, the Power FET generates heat. If the Power IC overheats (exceeding certain temperature, usually 125 to 150 degree Celsius), this circuit (inside power IC) turns off the IC and latches (to close or lock) it. Due to this, we need to unplug the AC supply and turn the power On again to restart the SMPS.

**Note:** This thermal shut down condition happens most probably due to three reasons:

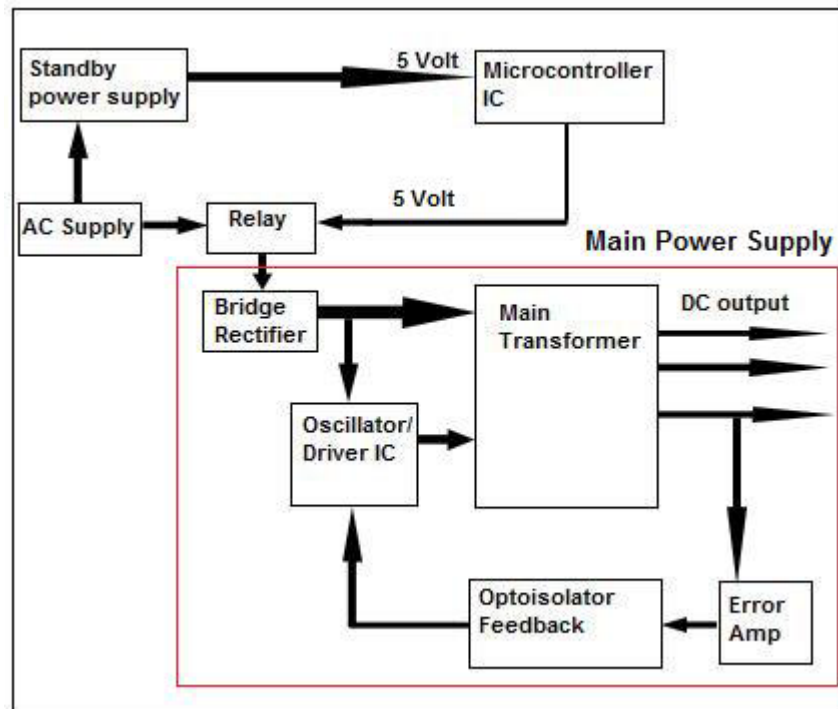
- The Power IC itself has overheating problem.
- There is no or not enough heat compound apply to the IC heatsink causing difficulty in transferring heat.
- The ventilation in the equipment itself is bad. For example, a faulty fan in the computer power supply could cause the power supply to shut itself off due to the hot air could not be sucked out.

**Note:** SMPS designers do not necessary have to use all of the three protection circuits (OVP, OCP and TSD protection circuit) in SMPS as mentioned above in their designs but it is necessary to have the **Surge Protection Circuit** in all SMPS. The designer could only use the OVP instead of OCP protection circuit and vice versa.

In order to fully understand how many protection circuits are used in SMPS (or electronic equipment SMPS), one has to get the exact schematic diagram to analyze it or to get the service manual where all of the protection circuits could be explained in that manual.

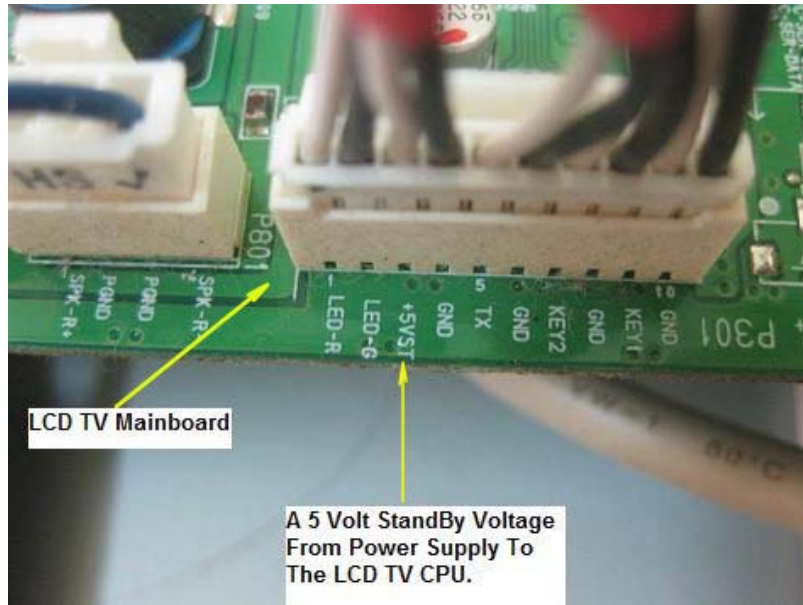
The arrangement of electronic components to form the protection circuits could be different from one design to another and all of the four protection circuits mentioned are only guidelines for you to understand how these protection circuits works.

#### 4.10) Standby Circuit

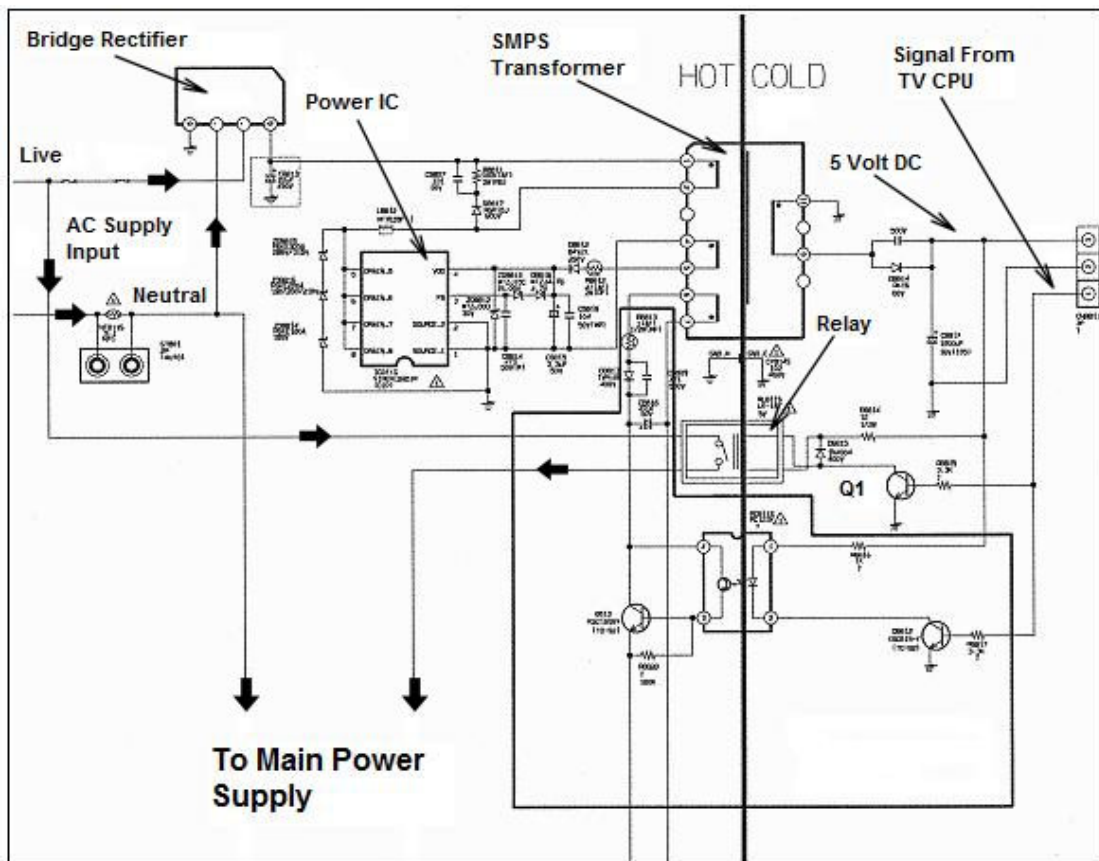


**Figure 4.27- Block Diagram Of A Typical Standby Power Supply**

Standby power supply circuit usually can be found in SMPS of electronic equipment like Television but very rare in the stand alone type of SMPS (not all SMPSs have standby power supplies). For your information, the standby circuit is always active when the Television is plugged into an AC line source. This supply is needed to deliver a 5 volt supply and a reset 5 volt to the Microcontroller IC to keep the Microcontroller functioning all the time, even when the Television is not operating (before you turn the Television “ON” using the remote control). These 5 volts are also needed to power the memory circuit (EEPROM IC), and remote control receiver circuitry.



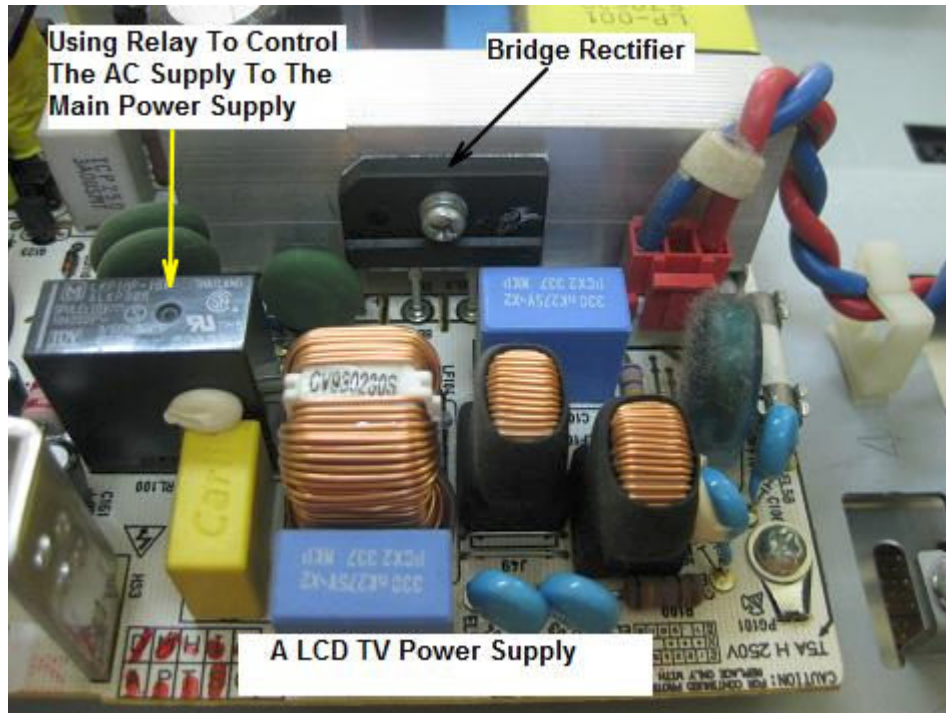
**Figure 4.28- A 5 volt StandBy Voltage Found In A 32” LG LCD Television**



**Figure 4.29- A Standby Power Supply Circuit**

Please refer to figure 4.29. When the Microcontroller IC (CPU) receives an ON command from the remote control or power button, on the front

of the Television, the Microcontroller IC sends 5 volt to relay drivers (Q1) and when Q1 conduct the relay closes, the AC supply is applied directly to the main power supply. The Main power supply starts to function and turns ON the television.



**Figure 4.30- CPU Controls The Relay. When The Relay Closes, The AC Supply Is Applied Directly To The Main Power Supply**

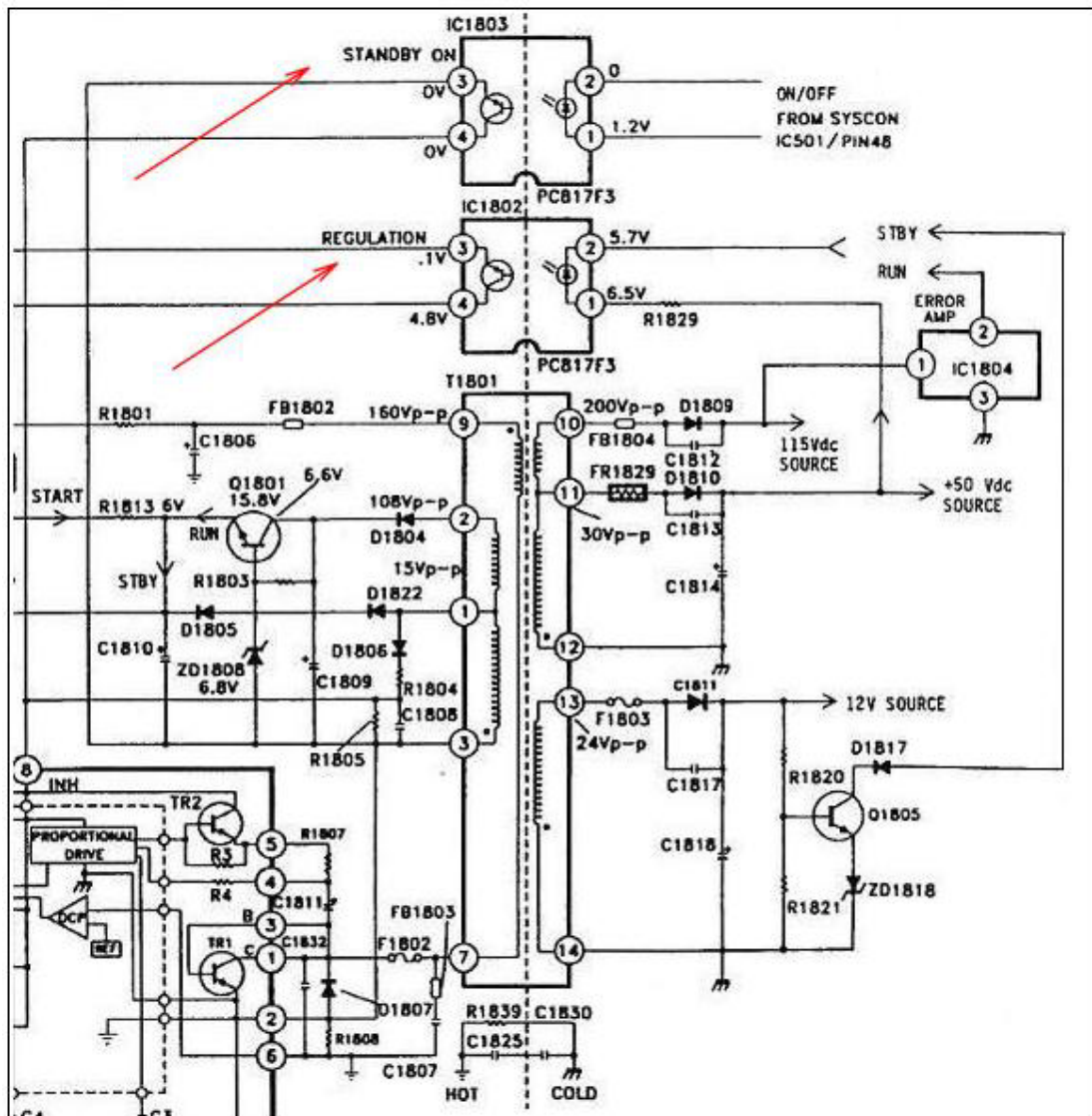
**Note:** The 5 Volt has to be present at Microcontroller, memory and remote control circuitry the moment you plugged in the AC power source. If missing 5 volts then check the standby power supply circuit. Remember that the standby circuit is also an SMPS.

Troubleshooting and repairing the standby power supply is just the same when you are checking the Main power supply. If the standby power supply did not have any output or have lower output than normal, you can start to trace from the AC input till the secondary diodes at the output. Since standby power supply design do not have many components (standby power supply is physically smaller and has lower power handling capabilities than the Main power supply), you can completely test all the electronic components with your meter in a very short time. **Remember that, the standby power supply have to function first before the Main power supply could work.** If the standby power supply has correct output but the main power supply is

still not operating then you should make sure that the Microcontroller IC is generating output that can trigger the relay so that the AC supply could flow to the Main power supply.

Assuming the Microcontroller is functioning then you should focus on the Main power supply section.

For your information, not all designs will use relay as many designs use Optoisolator IC to control the output power of the Main power supply. This means the moment the AC is plugged in, the standby power supply will output a 5 volt to Microcontroller IC and this IC will output a signal to Optoisolator IC to control the output power. In other words, this type of power supply will have two Optoisolator IC, one is for regulation purposes (refer to page 39-feedback circuit) while the other is for standby operation. Please see figure 4.31 in the next page.



**Figure 4.31- A Typical Standby Power Supply Circuit That Use Optoisolator IC To Control The Main Power Supply Output Power**

## **4.11) Power Factor Correction (PFC) Circuit**

### What is Power Factor?

Power factor (pf) is defined as the ratio of the real power (P) to apparent power (S), or the cosine (for pure sine wave for both current and voltage) that represents the phase angle between the current and voltage waveforms. The power factor can vary between 0 and 1, and can be either inductive (lagging, pointing up) or capacitive (leading, pointing down). When the current and voltage waveforms are in phase, the power factor is 1 ( $\cos(0^\circ) = 1$ ). Since this book is more on troubleshooting, I will only concentrate of its basic functions and will not touch on all the formula about power factor.

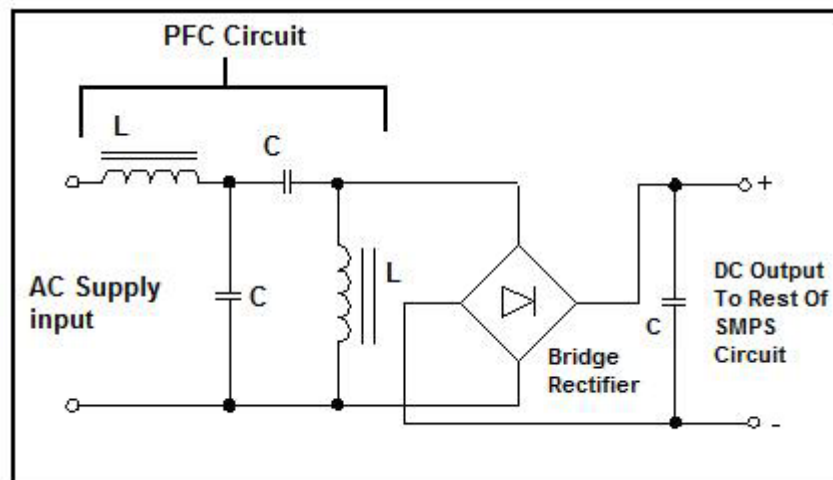
### What is Power Factor Correction (PFC)

Power Factor Correction is the practice of raising the power factor in order to allow power distribution to operate at its maximum efficiency. There are two types of PFC, Passive PFC and Active PFC. All of our power supplies are either Passive PFC Power Supplies or Active PFC Power Supplies. Those power supplies that do not have the PFC are called as Non-PFC Power Supplies.

Unlike most other appliances, switched mode power supplies tend to be constant power devices, drawing more current as the line voltage reduces. Also, in common with many static rectifiers, maximum current draw occurs at the peaks of the waveform cycle. As a result, the input current of such basic switched mode power supplies has high harmonic content and relatively low power factor than other types of appliances and this may cause stability problems for personal computers, computer monitors, TV receiver's power supplies and etc. European regulatory standards are now beginning to require power factor correction and harmonic reduction. This mean that the Non-PFC power supplies are no longer recommended. Power supplies are now required to have either Passive PFC or Active PFC.



## Passive PFC



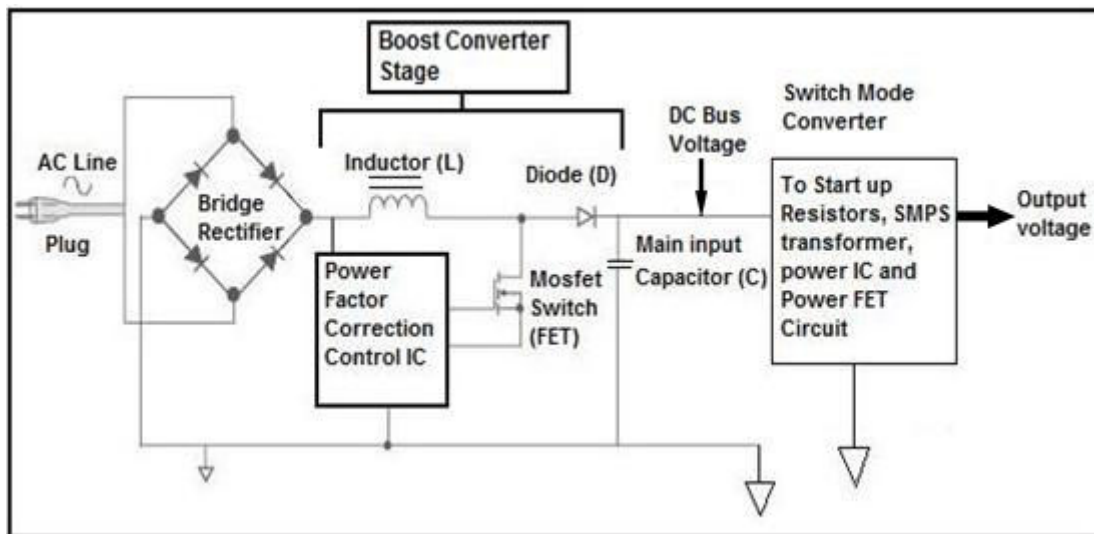
**Figure 4.32- A Typical Passive PFC Circuit**

The most common type of PFC is Passive Power Factor Correction (Passive PFC). This kind of design has the following advantages; namely they are low in cost, easy to design, simple structure and only require a filter to correct. However, they have the following disadvantages; large dimension of filter, heavy and low efficiency resulted from thermal and voltage decrease while current passes through the filter.

### How Passive PFC Circuit Works

Passive PFC circuits operate at mains frequency (50 or 60Hz) using passive components such as capacitors (C) and iron cored inductors (L) (see figure 4.32) tuned to the line frequency in a low pass or band pass configuration to filter the distortion's high harmonic wave, and only leave the 50 or 60 Hz basic wave in order to increase the power factor.

## Active PFC



**Figure 4.33- A Typical Active Power Factor Correction Circuit**

For any design over 100W, the preferable type of PFC is Active Power Factor Correction (Active PFC) since it provides a lighter and more efficient power factor control. This is because it uses a circuit to correct power factor. Active Power Factor Correction also diminishes total harmonics, automatically corrects for AC input voltage, and is capable of a full range of input voltage. Since Active PFC is the more complex method of Power Factor Correction, it is more expensive to produce an Active PFC power supply.

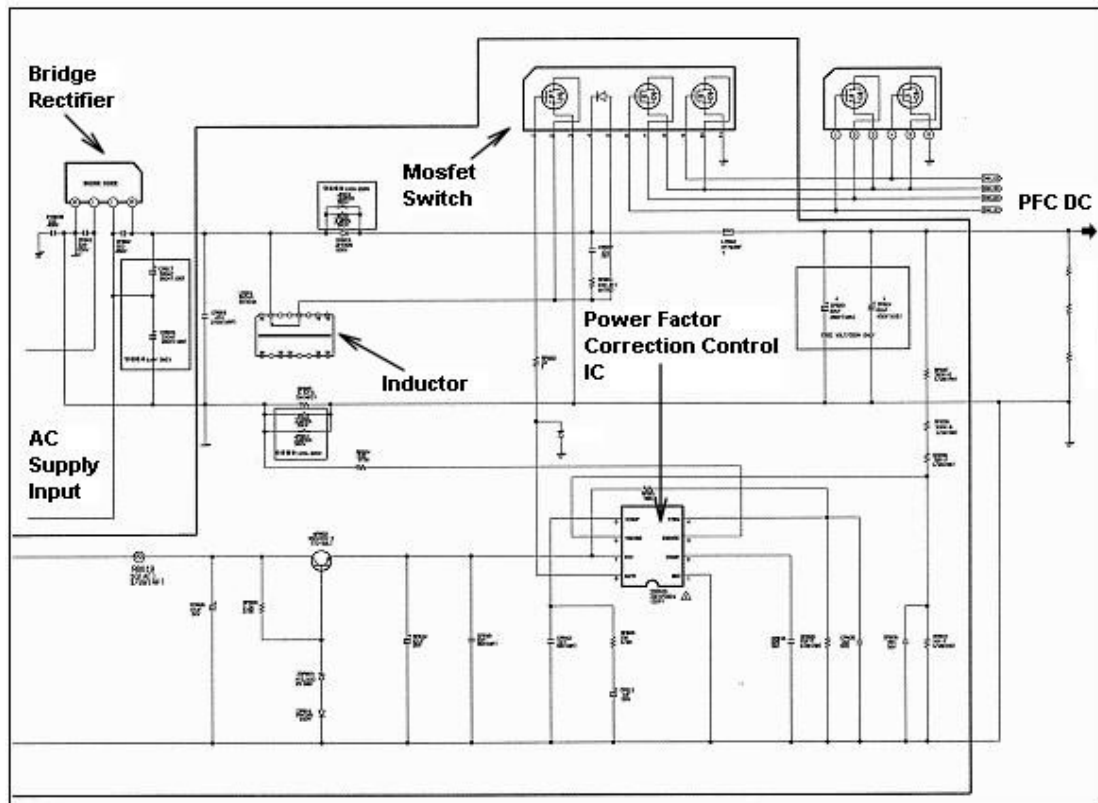
### How Active PFC Circuit Works

A boost converter is a DC to DC converter with an output voltage greater than the source voltage. A boost converter is sometimes called a step-up converter since it “steps up” the source voltage. Placing a current regulated boost converter stage between the bridge rectifier and the main input capacitor (figure 2) can help correct the power factor.

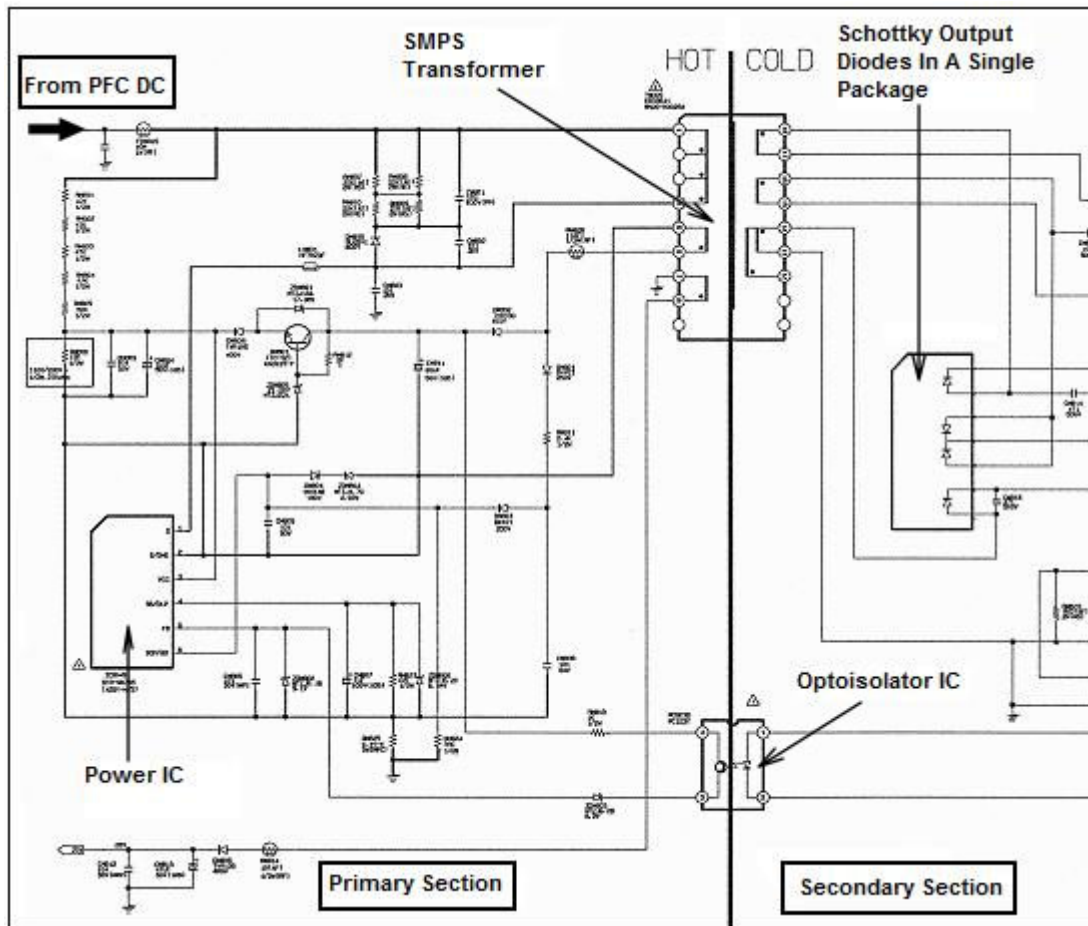
The inductor (L) is now connected in series with the unregulated input. When the Mosfet transistor is turned on by the signal from the Power Factor Correction Control IC a charging current flows through the Mosfet and through the inductor. This charging current stores energy in the inductor’s magnetic field. When the Mosfet is off, the field in the inductor begins to collapse. This induces a voltage across the inductor.

It can be seen that the inductor acts like a pump, receiving energy when the switch is closed and transferring it to the capacitor when the switch is

opened. The diode prevents main input capacitor (C) from being discharged when the switching Mosfet transistor is turned on again. The boost converter attempts to maintain a constant DC bus voltage on its output while drawing a current that is always in phase with and at the same frequency as the line voltage. Another switch mode converter inside the power supply produces the desired output voltage from the DC bus.



**Figure 4.34- A Typical PFC Boost Converter Stage In LCD TV Circuit**



**Figure 4.35- The LCD TV Main Power Supply DC Voltage Taken From The PFC Circuit In Figure 4.34**

If the active PFC controls IC and the Mosfet switch (FET) shorted, it will cause the main fuse to blow. Please check also the power FET and power IC for short circuit in the switch mode converter section of the SMPS.

Here is a typical power factor IC with the part number of MC33262D-X. For more information you can find this IC specification from the Internet.

Note: Not all SMPS use the power factor correction circuit (Non-PFC Power Supplies). For your information some new SMPS designs have the **power factor correction circuit built into a single power IC and is called PFC-PWM Controller IC**. You need to check the power IC data sheet to see if there is power factor correction circuit built into it or not.

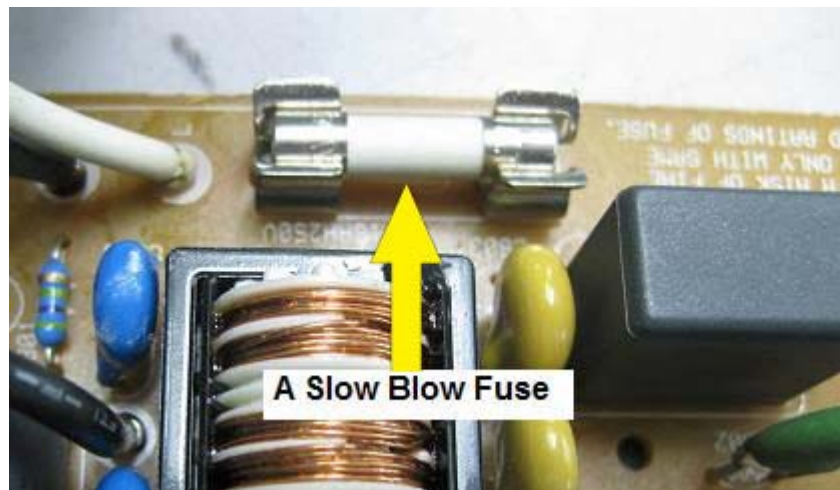
Conclusion- Whether it is a LCD TV, Plasma TV or any other types of power supplies in the market, the working principle is still the same. Understanding all of the circuits that I have explained above is very important for higher chances of success in SMPS repairing. Whenever if there is a problem with power supply you can at least know which section

gives problem and concentrate on that particular section. Since I could not cover all kinds of power supplies in the market, I urge you if possible to get the schematic diagram of the equipment power supply that you are working on and compare and analyze it by referring to the 11 circuits that I have explained above. Once you have truly understood your type of equipment power supply, troubleshooting and repairing the power supply would be much easier.

## **5) Electronic Components Found In SMPS** **And Possible Causes**

There are many types of SMPS designs in the market but overall almost all of them use the same electronic components to function. The only difference between a SMPS with another SMPS is the location and the quantity of electronic components used! For example, an “A” SMPS could have slightly more components than a “B” SMPS and etc. It could also be that “A” SMPS uses the PWM IC while the “B” SMPS does not have any (older designed). No matter what kind of designs a SMPS is, it must have the electronic components that are listed below in order to function. I will also explain the possible causes that these electronic components can cause.

### **1) Fuse**

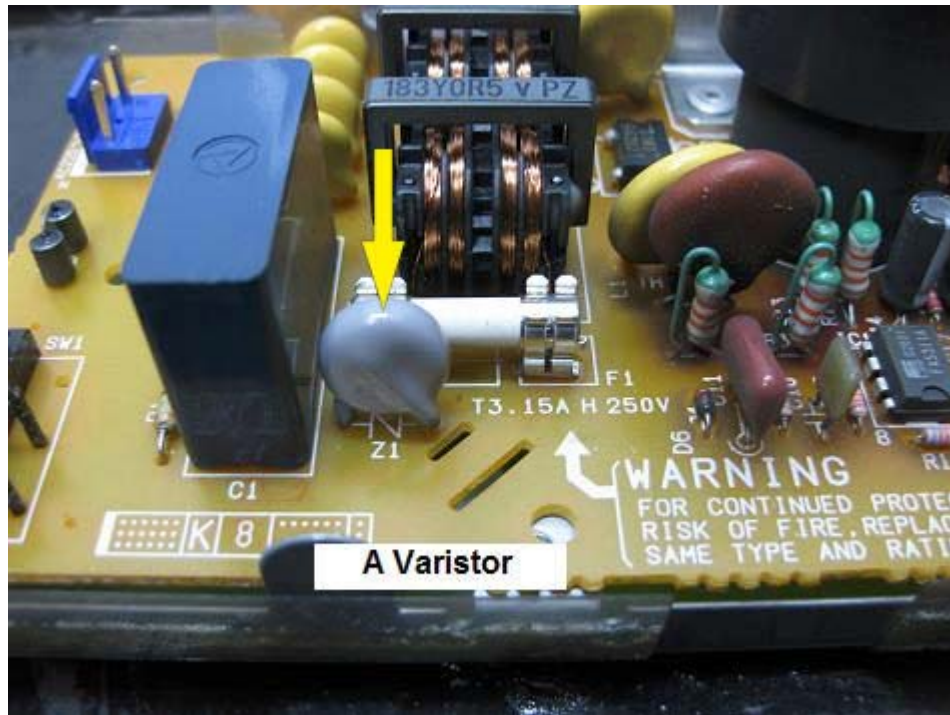


**Figure 5.1- A Slow Blow Fuse**

Fuse (**board location marked as “F”**) – The purpose of a fuse is to open an electronic circuit when current flow exceeds a certain amount, determined by the fuse rating. Opening a circuit under a high current conditions can save electronic components from damaged and prevents overheating, which could cause fire. The fuse can breakdown on its own due to the life span or from a mild surge. Normally in this condition, replacing with a new fuse will solve the problem. In some cases, you could see that the glass type fuse was totally blown into black/dark colour. If this happen, replacing only the fuse would not solve the problem as the dark colour fuse indicated there was a major short circuit in the power supply. In this case, you have to spend a little bit more time

to find out the fault before putting a new fuse and retest the power supply. Remember to use the light bulb trick that was covered in chapter 13 to solve the heavy short circuit problem.

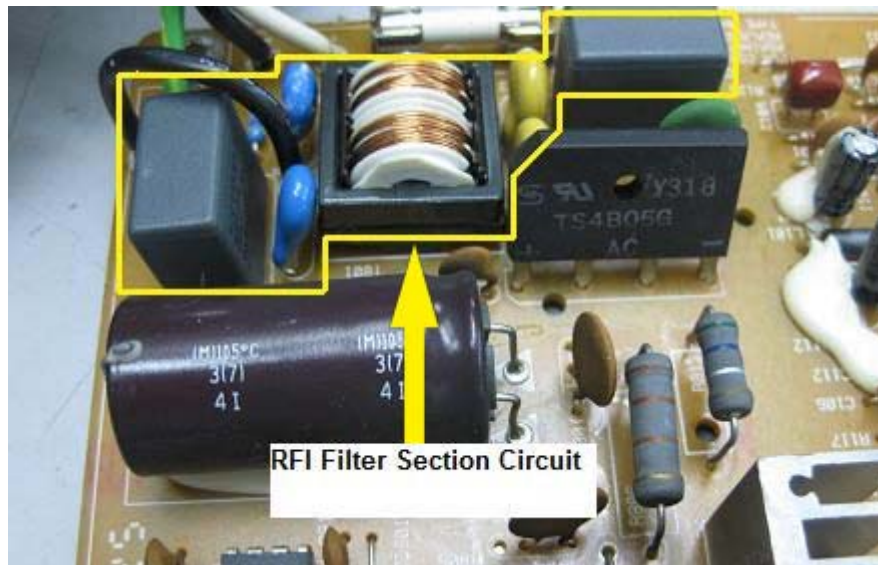
## 2) Varistor



**Figure 5.2- A Varistor**

Varistor (**board location marked as “Z”, “RV” or “ZNR”**) - Metal Oxide Varistor (MOV) is voltage dependent symmetrical resistors intended to protect equipment from transient voltages resulting from lightning strikes and it has many colours. This component is located near the ac supply input and before the bridge rectifier. The use of MOV not only reduces the chance of electrical damage but also improves equipment reliability. Whenever the Varistor has problem, the top part always darkens in colour and splits open (blown)! In order to test MOV you can use an analogue meter set to X 10 K ohm and it should show no reading on both ways. If there are any readings, then it had developed a short circuit.

### 3) EMI/RFI Filter Section

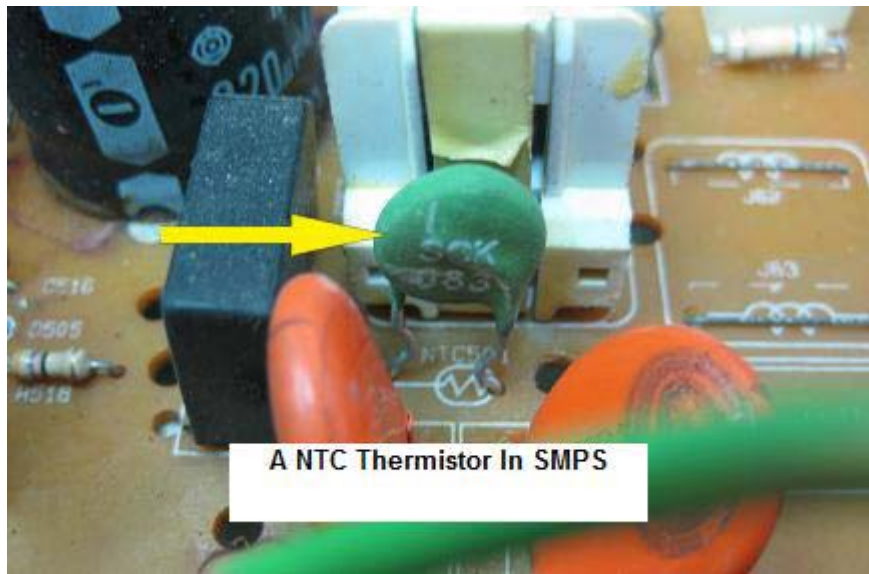


**Figure 5.3- EMI/RFI Filter Circuit**

EMI/RFI filter section (**board location marked as “L” and “C”**) - EMI (Electromagnetic Interference), also known as RFI (Radio Frequency Interference), is unwanted electromagnetic energy polluting the environment. Its propagation via radiation and power conduction over system signal and power lines can affect the operating of electrical equipment around the source. This circuit consist of one or two coils and usually one or two non polarity capacitor depending on the design. Sometimes these components are integrated into a module as seen in figure 5.3. The function of this circuit is to attenuate leaking magnetic field to avoid Radio Frequency Interference. This circuit is quite robust unless if a lightning strikes that could easily destroy the coils. You can test the coil with a normal multimeter set to ohms range and the non polarity capacitor with a digital capacitance meter.



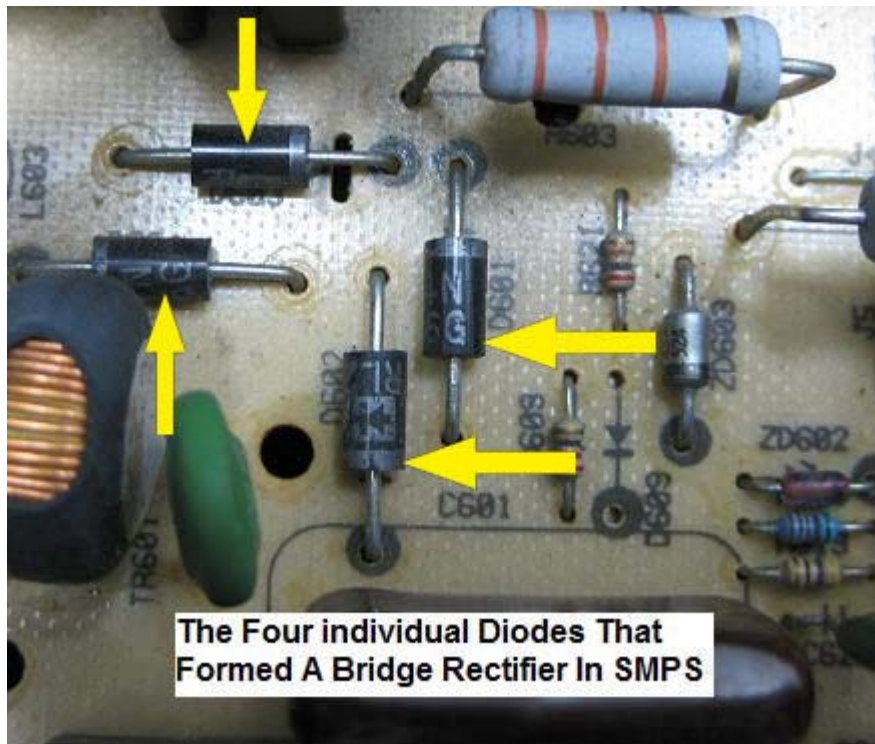
#### 4) Negative Temperature Coefficient Thermistor



**Figure 5.4- A Thermister**

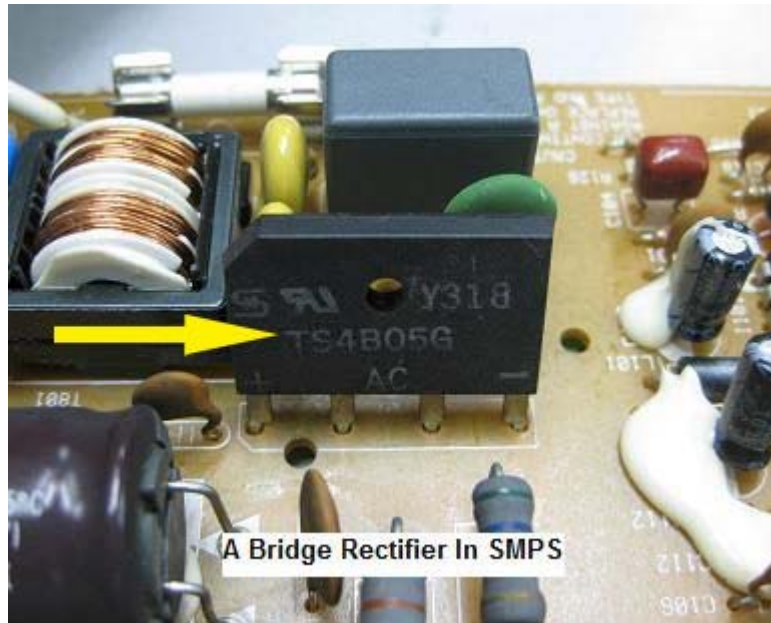
Negative temperature coefficient (NTC) Thermistor (**board location marked as “TH”, “R” or “NTC”**) - The function is to limit the inrush current that can kill the components in the power section during start up. An NTC Thermistor has a relatively high resistance at room temperature, so at turn-on, it limits the current charging the load’s rail capacitors. As the Thermistor heats up, its resistance drops, so the power supply becomes relatively low impedance. You can test it using an analogue meter set to X 1 Ohm and it should show a low ohms reading. For your information not all SMPS use this component in their design. In some SMPS, the designer may add in a resistor in series (usually low ohm resistor with higher wattage) to the input to limit the **initial peak inrush current** whenever the power supply is switched on.

## 5) Bridge Rectifier



**Figure 5.5- Four Diodes That Forms The Bridge Rectifier**

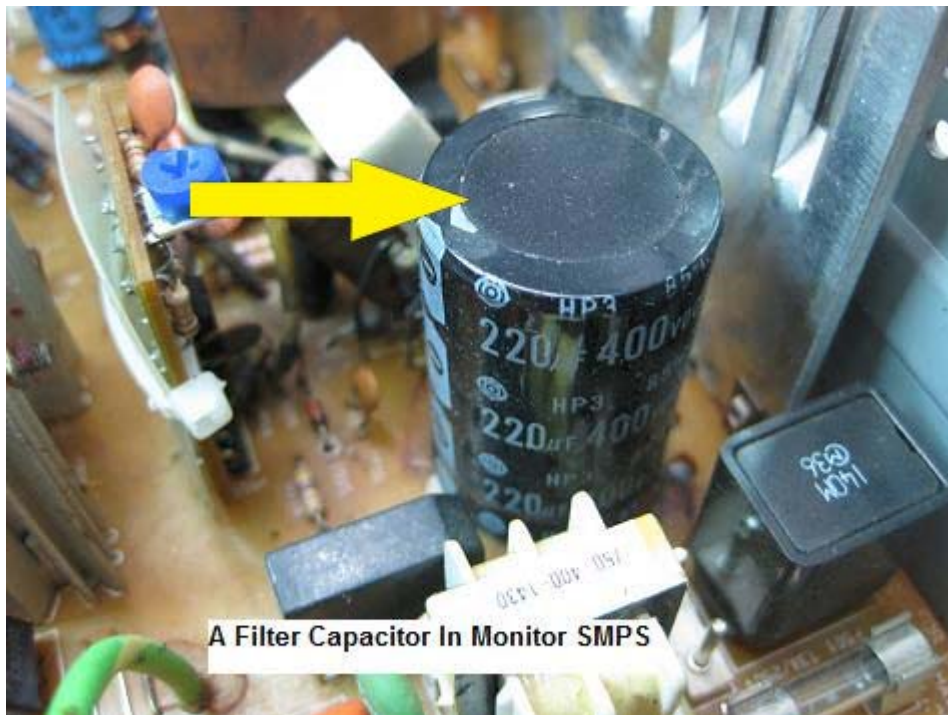
Bridge Rectifier (**board location marked as “D” or “BR”**) - Bridge rectifier can come in 4 individual diodes or in a single package. It depends on the design engineers as which type they want to use. In the four individual diodes bridge arrangement, if one diode is found to be shorted, you have to replace the other three. The reason for it is if you do not replace the other three, there could be a high chance one of the three diodes will go shorted again, I had came across this problem before and I don't want you to follow my path of saving money and end up getting the same complaint again (no power) from the same customers.



**Figure 5.6- Bridge Rectifier**

As for the bridge rectifier in a single package, if one diode is found to be faulty, you have to replace the whole package. Assuming if you can't get the spare part, you can always make yourself a bridge rectifier from four individual diodes. You may use four pieces of diode with the part number of 1N5408 to make a bridge rectifier. This part number is best use for most of the consumer electronics circuit. Whenever you come across a blown fuse, please test the bridge rectifier first before you replace it with a new fuse and retest the power supply. Please refer to chapter 13 for more information about replacing a new fuse without blowing it again. I came across a bridge rectifier (package type) that breaks down when under full load. This means that the bridge rectifier checked to be okay with a multimeter, but the fuse blown when power was "On" (full load). If you come across any case where you can't find out the cause of why the fuse was blown, then just directly replace the bridge rectifier and retest the power supply again.

## 6) Large Filter Capacitor



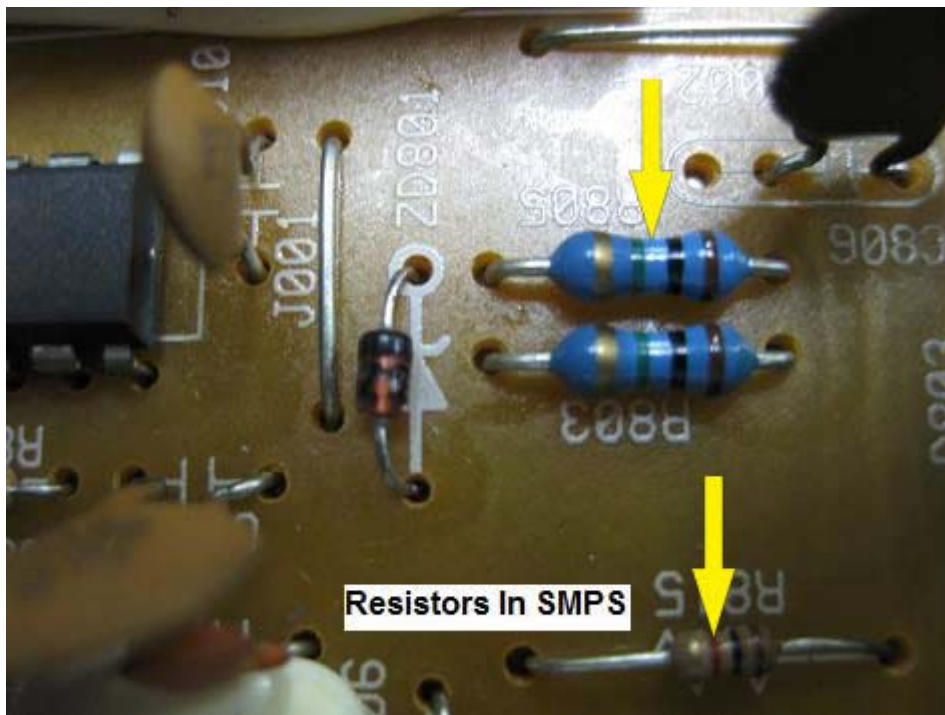
**Figure 5.7- Filter Capacitor In Primary Side Of SMPS**

Filter capacitor (**board location marked as “C”**) - This is the biggest electrolytic capacitor found in any SMPS. The function is to remove the ripple in the line and provide a clean DC to the circuitry. This capacitor has four common failures:

- Bulged- The top part aluminium cap opens up (or exploded) indicates an over voltage problem.
- Open circuited- The capacitance dropped to zero value indicating the internal part are already broken or the electrolyte has been dried up.
- High ESR- Some filter capacitors have a good capacitance value but the ESR value shoots up causing the power supply to stop working. The electrolytic capacitor ESR value can only be measured by using an ESR meter.
- Short circuited- A short circuited filter capacitor can be completely blown up the fuse. It is quite rare to have a short circuit filter capacitor but I have come across some cases. Set your analogue multimeter to X 1 Ohm and check across the two leads. It should not show any steady reading on both directions.

- Breakdown when under load- Although it does not happen that frequent, it does happen especially when you have tested all of the components in the power side area and still could not locate why the fuse keep on blowing upon power “On”. The filter capacitor can be tested okay with analogue, digital capacitance meter or even ESR meter but failed when the full voltage apply across it. This kind of problem can only be detected by using an insulation tester. If you have the experience of the fuse keep on blowing even after you have completely checked all of the components, then directly replace the filter capacitor and retest the equipment.

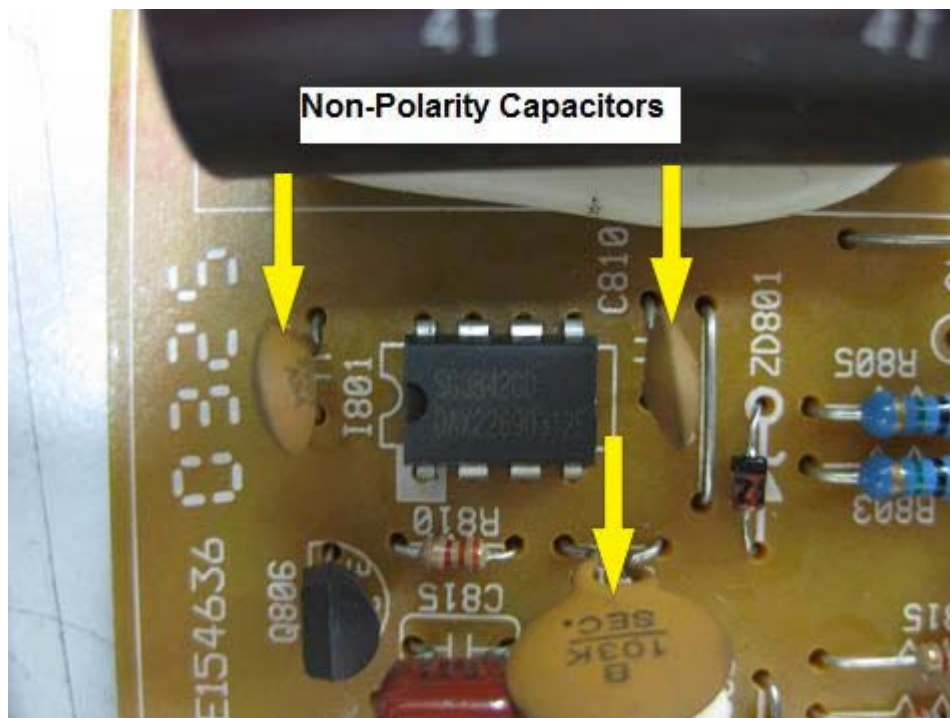
## 7) Resistor



**Figure 5.8- Resistors**

Resistors (**board location marked as “R”**) - The function of resistor is to limit current in electronic circuit. Resistor problems could be in the form of open circuit, turn into high ohms, and burnt, discoloured, broken leads due to rust and even intermittent problem (quite rare). By using only the digital multimeter set to Ohms range, you will be able to detect most of the resistors faults in power supply circuit.

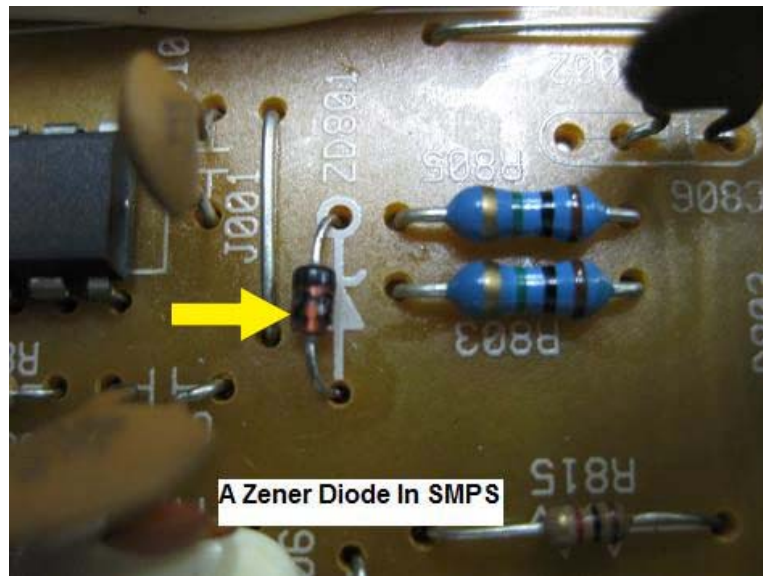
## 8) Non Polarity Capacitors



**Figure 5.9- Non Polarity Capacitors**

Non polarity capacitors (**board location marked as “C”**) - These capacitors can be found in the RFI circuit and in primary side of power supply. Some of these capacitors are part of the oscillator circuitry. The problems that these capacitors can cause are open circuit, capacitance value out and short circuit. Sometimes under heavy short circuit in the power supply, these capacitors could crack and will have burnt mark and split open. In order to test these capacitors, you can use a digital capacitance meter to test the capacitance value and an analogue meter set to X10 K ohm to check for short circuit. The pointer should come down after the capacitor is fully charged.

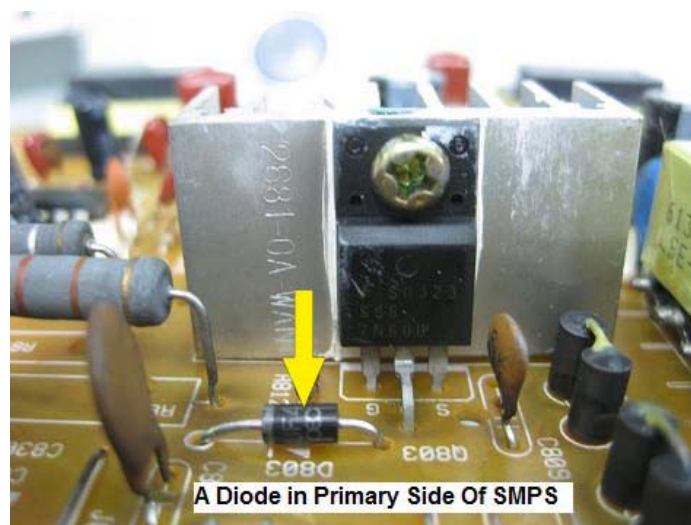
## 9) Zener Diode



**Figure 5.10- Zener Diode**

Zener diode (**board location marked as “D” or “ZD”**) - Not all SMPS use Zener diode in the circuit. For those SMPS that use the Zener diode, it is meant to protect the power IC and to shutdown the power supply, in case if there is overvoltage (refer to page 43). Zener diodes can develop short circuit or open circuit or even leak when test with an analogue meter set to X 10 K Ohm.

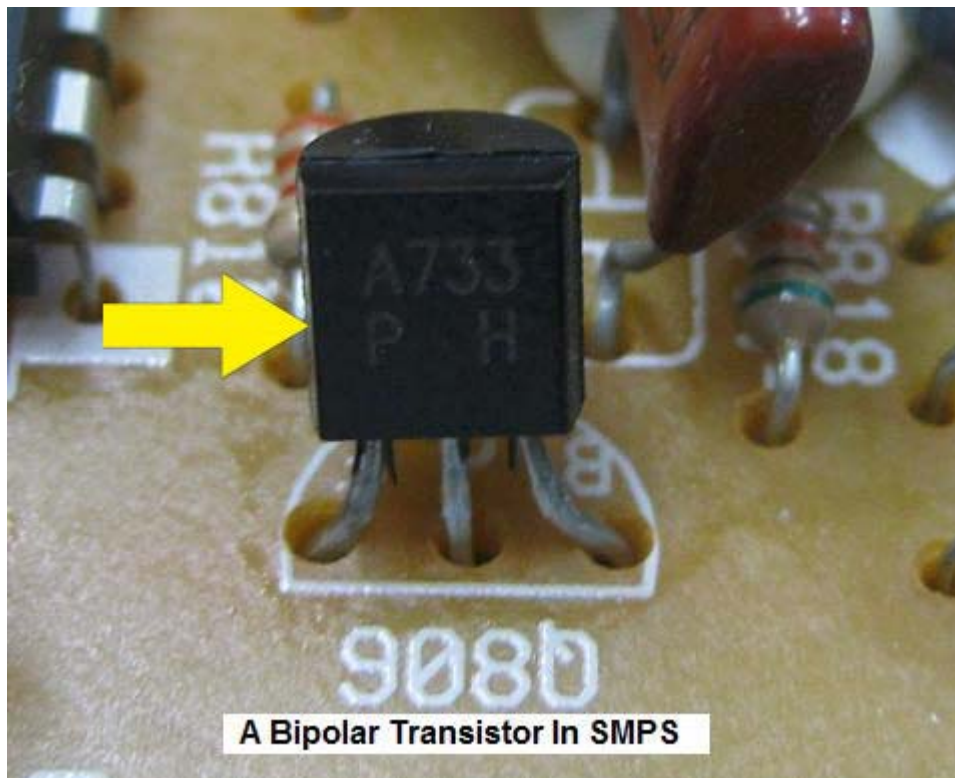
## 10) Diode



**Figure 5.11- Diode**

Diodes (**board location marked as “D”**) - You could see some small signal diodes that have the marking of IN4148 and small ultra fast recovery diodes (like BA159 and UF4004 and etc) in the power supply primary section. The signal diodes could be part of the oscillator circuit and the ultra fast recovery diode is to convert the AC voltage into DC to supply to the power IC. For your information the diode in the RUN DC circuit is an ultra fast recovery diode (refer to page 29). This diode can be shorted, open circuited, leaked and even breakdown when under load.

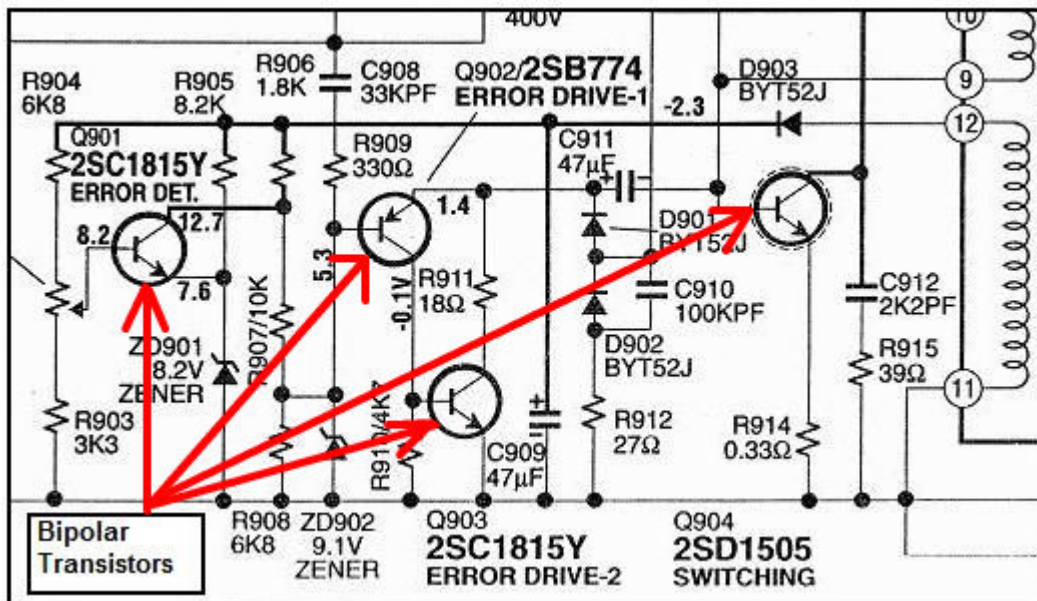
### 11) Bipolar Transistor



**Figure 5.12- A Bipolar Transistor**

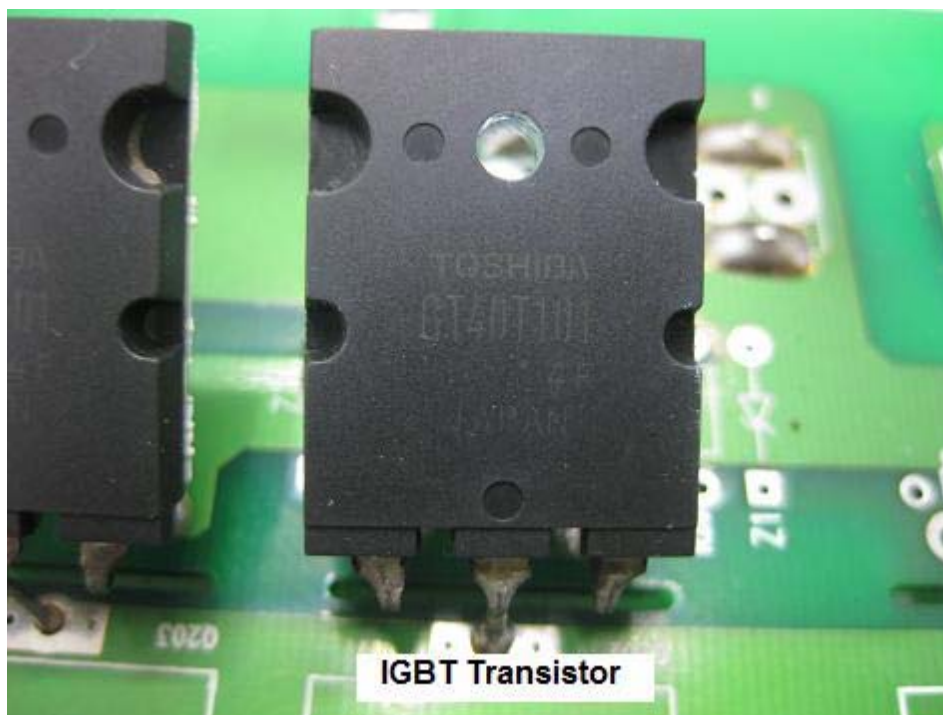
Bipolar Transistors (**board location marked as “Q”**) - For older model of SMPS you could see **more** transistors compare to a newer model of SMPS. The transistors are part of the oscillator circuit and it could develop short circuit, open circuit and leaking that caused the power supply to totally stop working. It could also like diode, breakdown when under full operating voltage.





**Figure 5.13- Bipolar Transistors In SMPS Circuit**

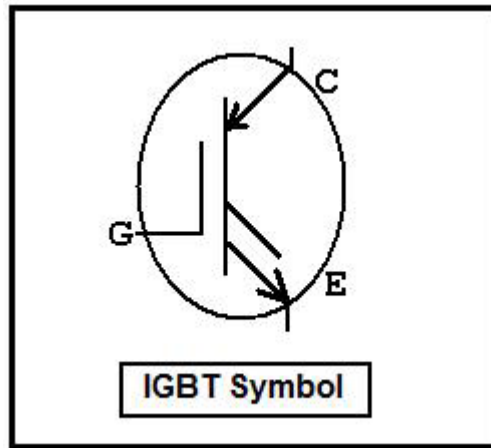
12) IGBT Transistor



**Figure 5.14- IGBT Transistor**

IGBT is a short term for the Insulated Gate Bipolar Transistor (**board location marked as “Q”**) – This device is a combination of bipolar transistor and Mosfet. The emitter and collector of the IGBT device is the same as they are in a bipolar

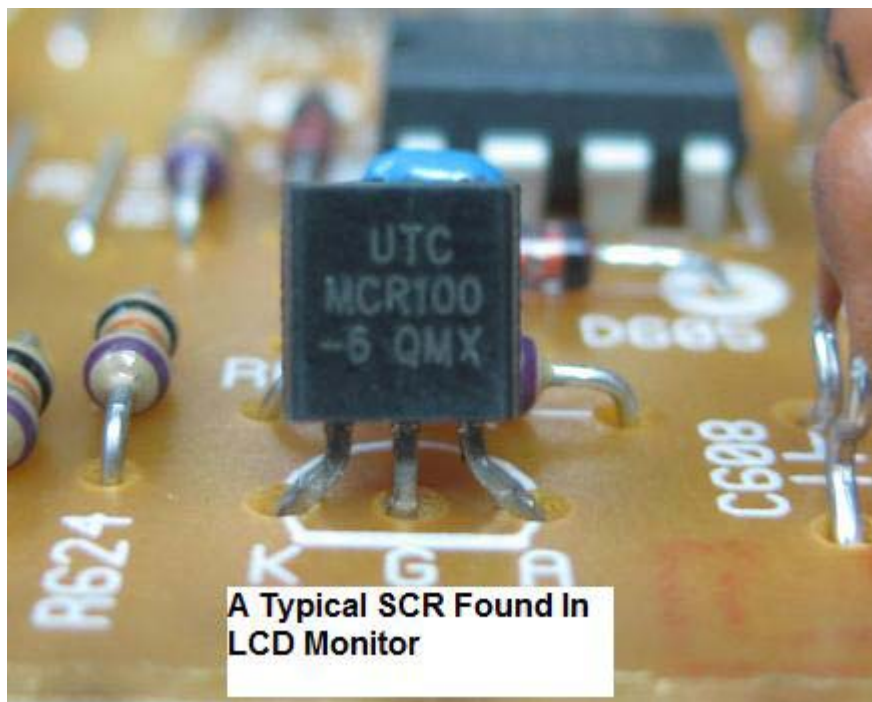
transistor, the IGBT has insulated gate, as it is found in Mosfet device as seen in the diagram below. This transistor can be found in SMPS, Induction heating, Traction Motor, Uninterruptible Power Supply (UPS) and etc.



**Figure 5.15- IGBT Symbol**

Like the bipolar transistor the IGBT could develop short circuit, open circuit and leaking that caused the power supply to totally stop working.

### 13) **Silicon Controlled Rectifier (SCR)**

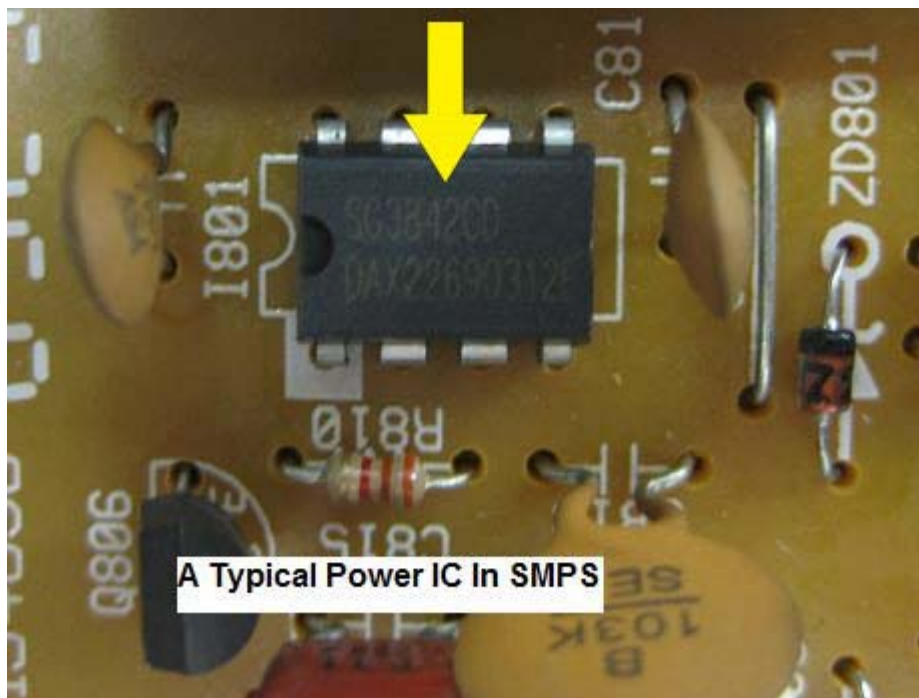


**Figure 5.16- A Silicon Controlled Rectifier**

SCR (board location marked as “Q”) can be found in many electronic circuits. Part numbers such as the FOR3G and MCR 100-6 are commonly used in Computer Monitor especially in the primary power side. The SCR can also be found in overvoltage protection circuit in secondary side of some SMPS. SCR consists of three pin of Gate (G), Anode (A) and Cathode (C). In order to identify the pin out, one must find it from semiconductor data book. The data book will list out the general specification of the SCR such as the volt and ampere.

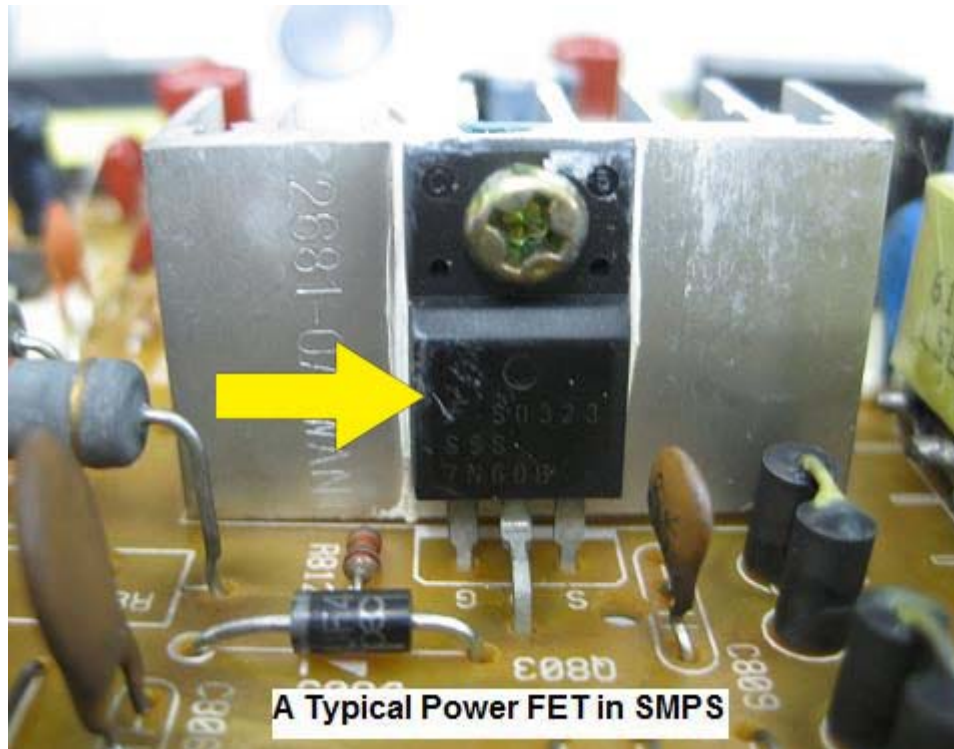
If you want to know more details about a particular SCR, you can always try to search from the Internet. You can usually download the full datasheet from the SCR manufacturers. When this component encounters a problem, it could cause no power, power blink and even power shutdown in power supply.

#### 14) Power IC



number it is, the main function is to generate an output waveform to drive transistor. In some power IC the transistor has already **integrated into the power IC itself**. The common Power IC failures are no output waveform, shorted, cracked and outer layer blown up by surge and etc.

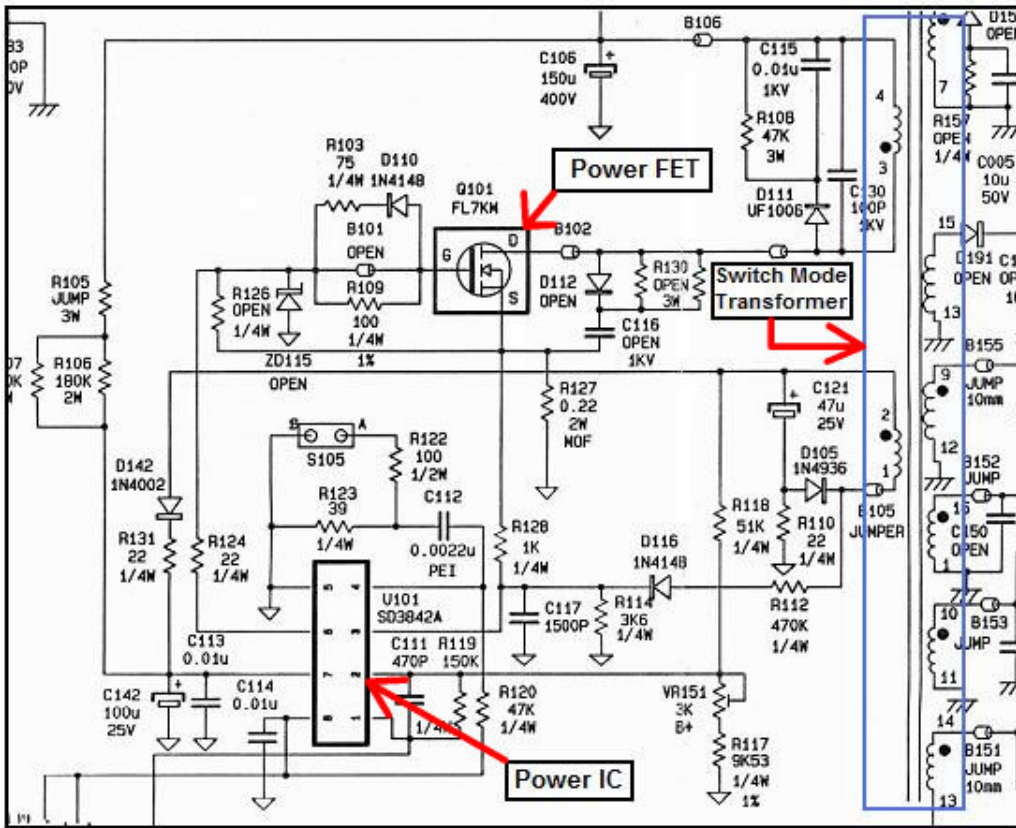
### 15) Power FET



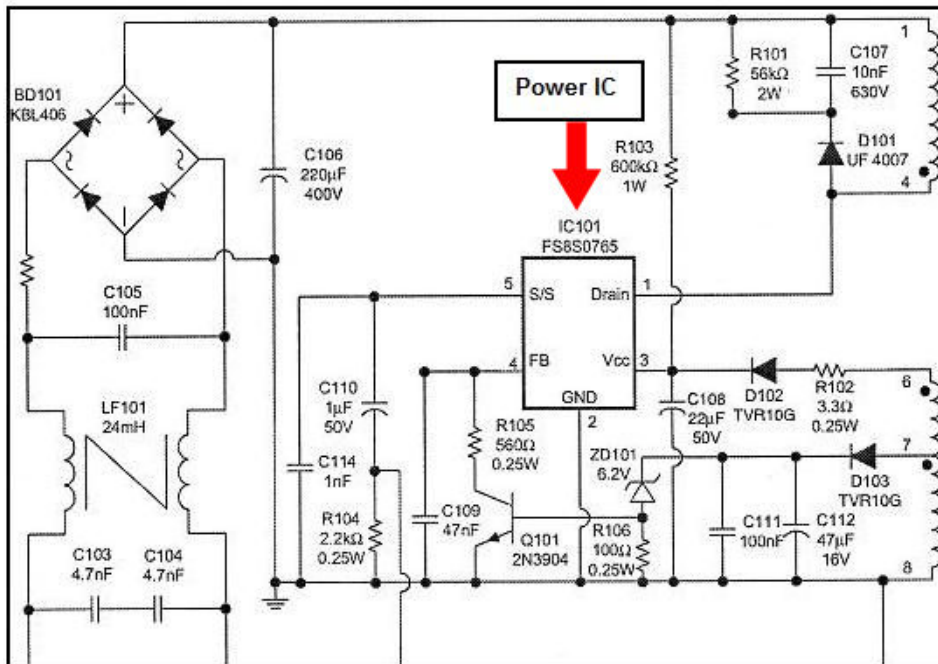
**Figure 5.18- A Typical Power FET**

Field effect transistor (FET) (**board location marked as “Q”**) – This FET transistor is used to switch the SMPS transformer when it gets the signal waveform from the power IC. It is usually the N-channel FET transistor and can be easily become defective whenever there is a surge in the power supply or some components have shorted in the corresponding circuit or in the secondary side. The common faults for this type of transistor are almost the same as power IC like short circuit, open circuit, cracked and even the outer layer coming off from its casing.

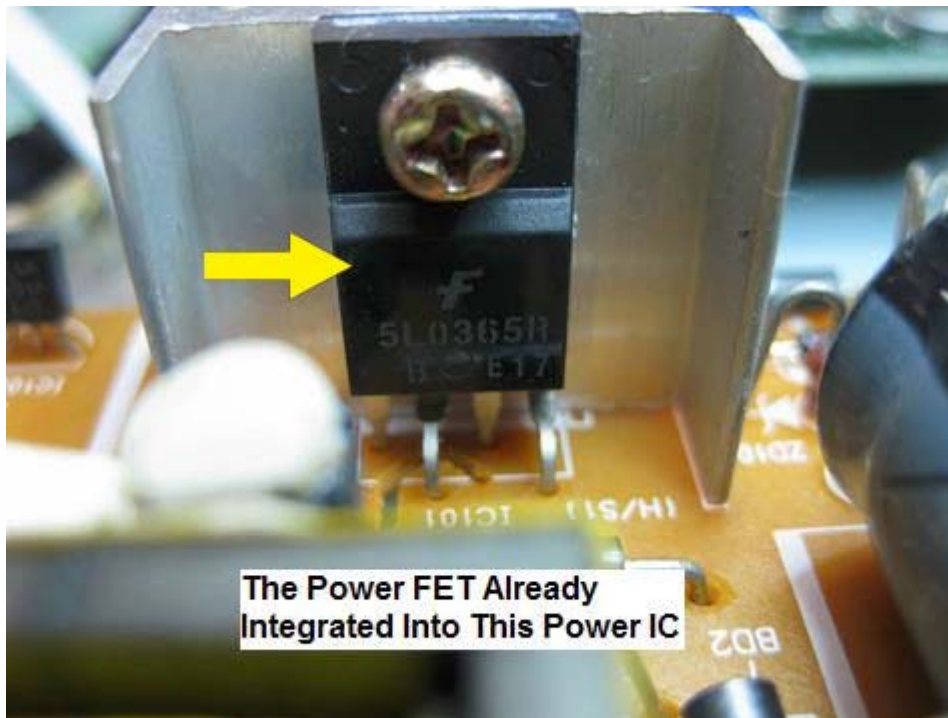
**Note:** Newer power supply may not use the power FET anymore because the FET has already integrated into the power IC as one single package. So do not waste your time searching for this FET in the newer power supply circuit. Please refer to figure 5.19 and 5.20.



**Figure 5.19- Schematic Diagram Showing A Power FET And A Power IC**

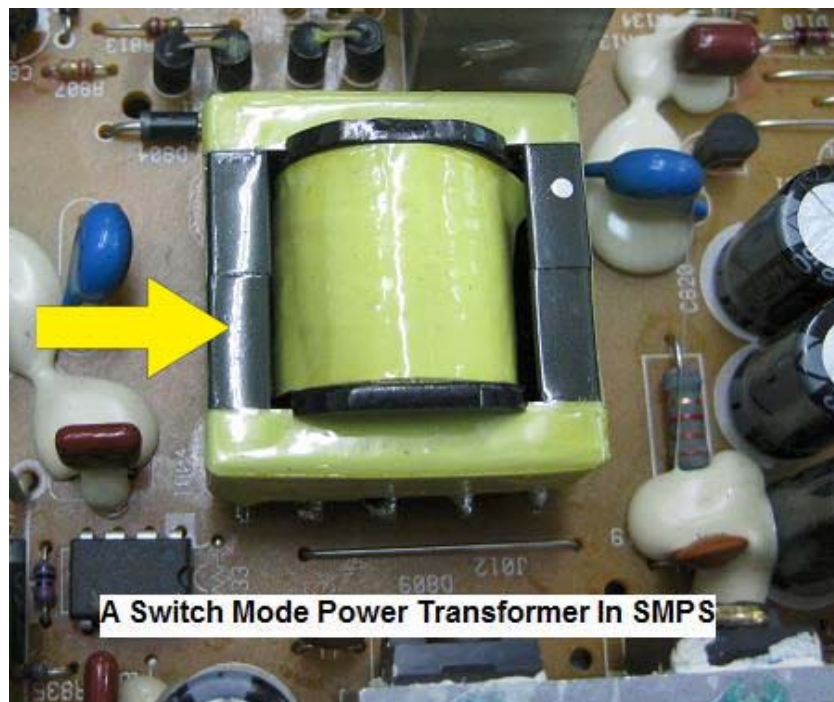


**Figure 5.20- Schematic Diagram Showing The Power FET Already Built Into The Power IC.**



**Figure 5.21- The Power FET Already Built Into The Power IC**  
**(Observe That It Has More Than 3 Legs)**

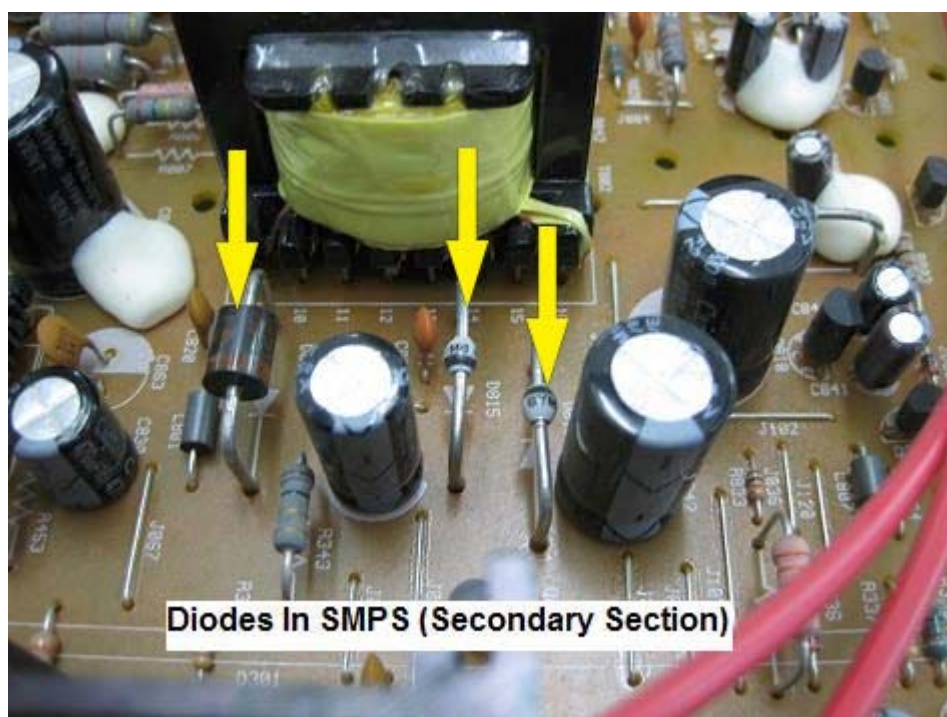
16) **Switch Mode Power Transformer**



**Figure 5.22- A Switch Mode Power Transformer**

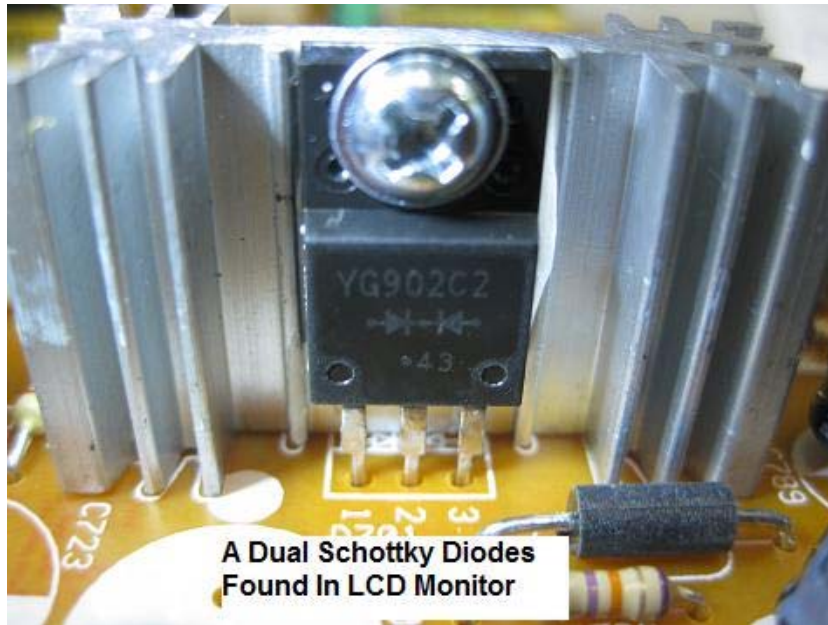
Switch mode power transformer (SMPT) (**board location marked as “T” an sometimes “TR”**) – The transformer function is to convert the AC input into another AC output of different voltages. SMPT rarely has problems but when it encounters problems, the main fuse will usually blow and the components in the primary side may be affected as well. A shorted turn in the primary winding is the main problem for SMPT. You have to use a coil tester (**Blue Ring Tester**) to test the primary winding. Secondary winding seldom gives problem and when it has problem, one or few of the output voltages will drop to half.

### 17) Secondary Output Diodes

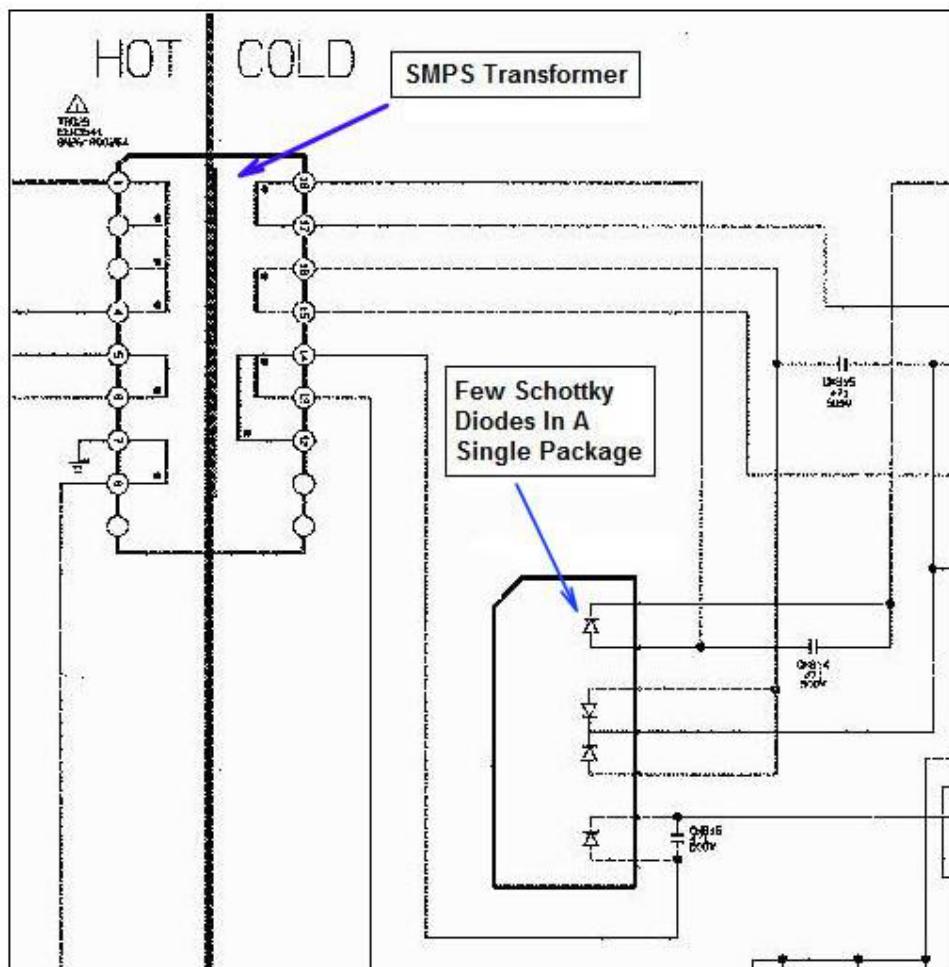


**Figure 5.23- Typical Output Diodes In The Secondary Side Of SMPS**

Secondary output diodes (**board location marked as “D”**) – These are ultra fast recovery diodes (high speed) and not ordinary diode and their job is to convert the high pulse AC signal voltage into DC output voltage. High speed diodes are used to handle the very fast switching action of the power supply. SMPS usually have two or more output DC voltages. Some design uses a Schottky diode or Dual Schottky diodes or even few Schottky diodes in a single package and can be found in LCD TV and LCD Monitor power supply. Refer to figure 5.24 and 5.25 in the next page.



**Figure 5.24- A Typical Dual Schottky Diode**

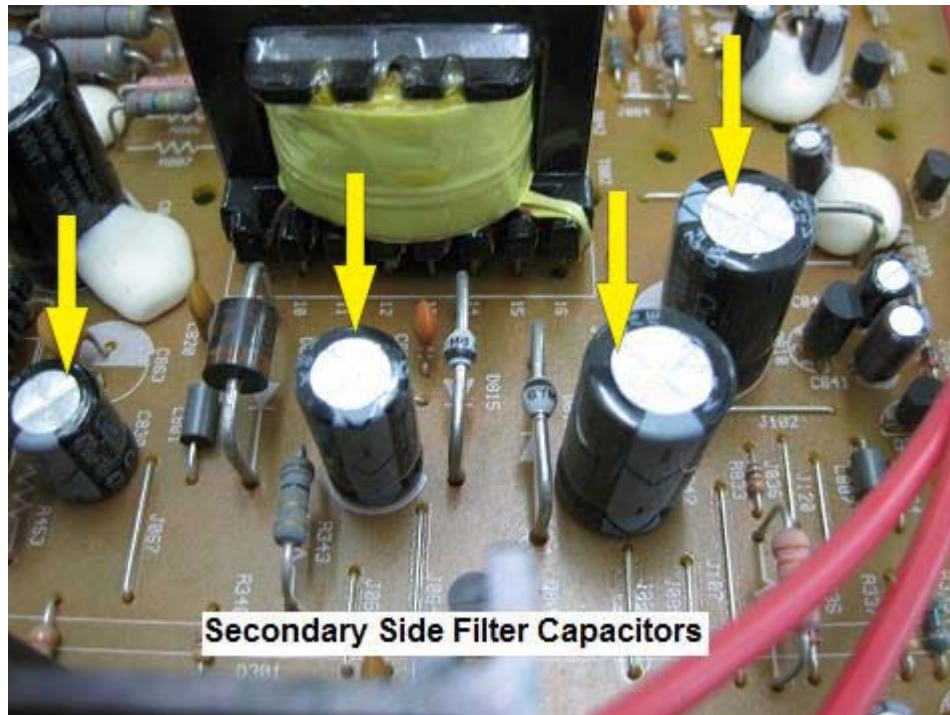


**Figure 5.25- Few Schottky Diodes In A Single Package Found In LCD Television**



The common faults for the diodes are short circuit, open circuit, leaking and cracked! You can test the **ultra fast recovery diode** using analogue meter set to X10 K ohm and it should have only one reading.

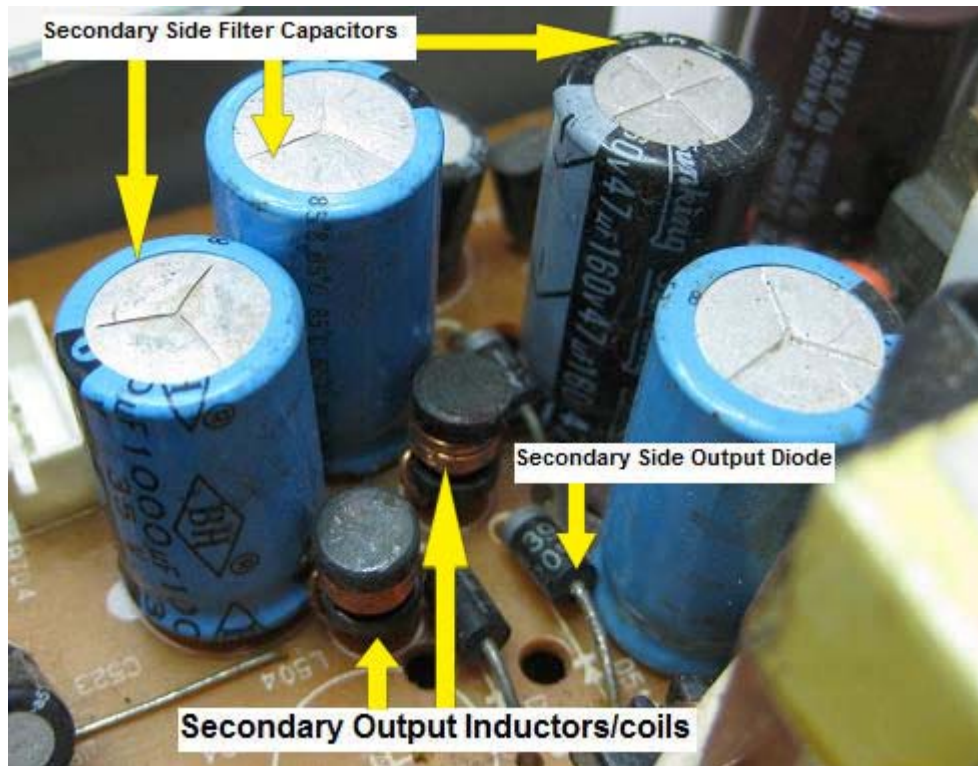
### 18) Secondary Filter Capacitors



**Figure 5.26- Filter Capacitors In Secondary Side Of SMPS**

Secondary output filter capacitors (**board location marked as “C”**) – Same explanation as in page 68 except that it is not as big as the big filter capacitor in the primary side.

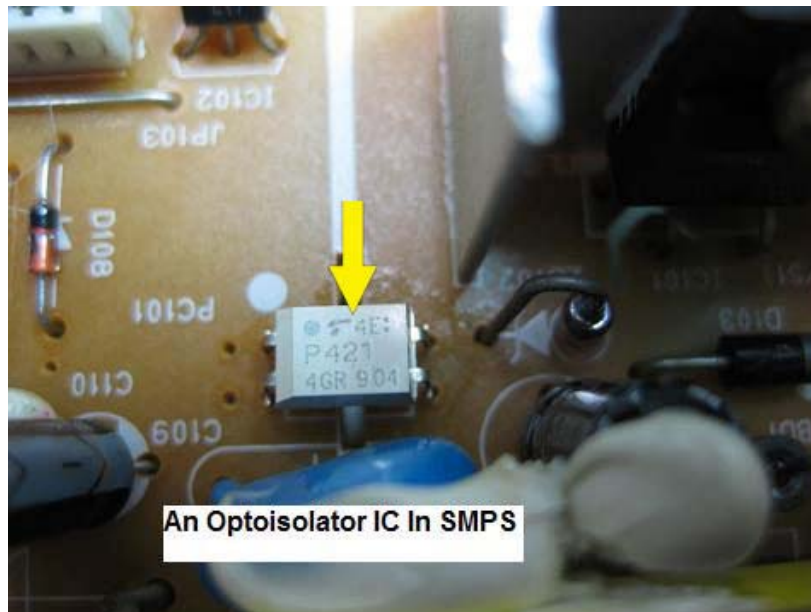
## 19) Secondary Output Inductors/Coils



**Figure 5.27- Inductors/Coils In Secondary Side Of SMPS**

Secondary output inductors/coils (**board location marked as “L”**) – The function is to filter any unwanted AC and let DC to pass through. These coils rarely have problem and if there were any problem, it would be the **decayed glue** that had eaten up the leads. Sometimes you can also find dry joints in these coils. If the coil was opened circuit, the DC voltage couldn't get through and the circuit area will be affected because no DC supply had entered the respective ICs and circuits. You can test these small coils using ohm meter and it should have low ohm reading.

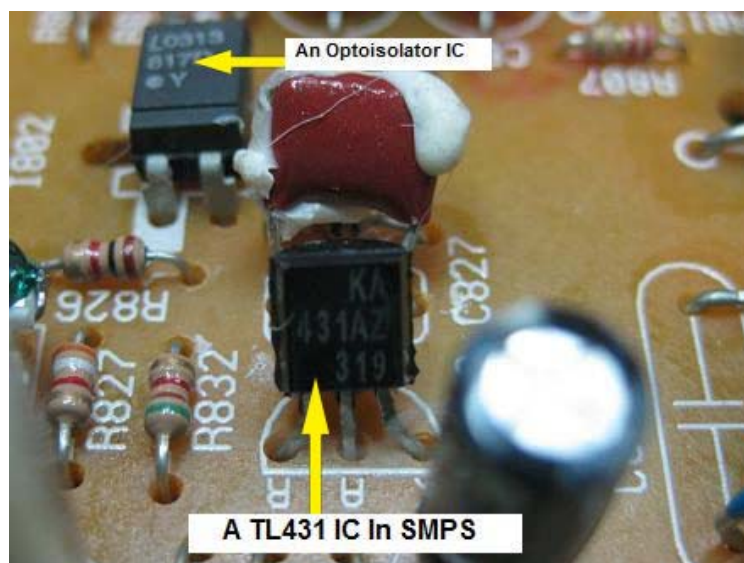
## 20) Optoisolator IC



**Figure 5.28- A Typical Optoisolator IC In SMPS**

Optoisolator IC or Optocoupler (**board location marked as “IC”**) – One of the main function of Optoisolator IC in SMPS is to monitor the output voltages so that the output voltages would not fluctuate if there was a slight change in the main input voltage. If the Optocoupler IC breakdown, it would cause the equipment to have low power, blink, no power, erratic power and even power shut down once the SMPS is switched “ON”.

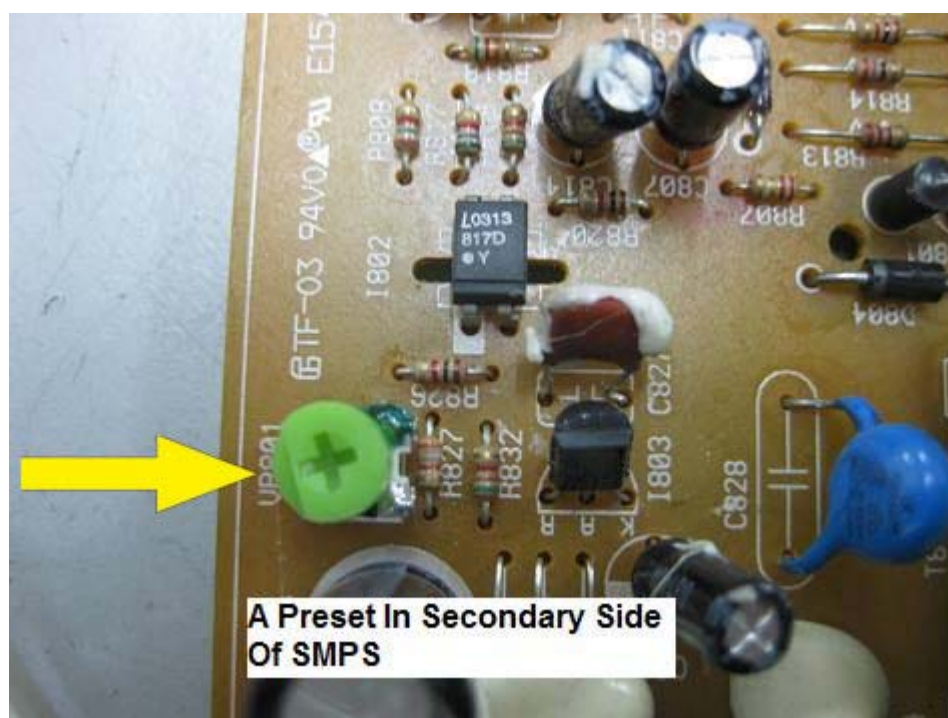
## 21) Adjustable Precision Shunt Regulator IC



**Figure 5.29- A TL431 IC In SMPS**

Adjustable Precision Shunt Regulator IC (**board location marked as “IC”**) If you repair the SMPS that have the Optoisolator IC connected between the primary and the secondary section, you would usually see a transistor like component. It is actually the **adjustable precision shunt regulator** with the part number of TL431 and it just like the shape of a C945 transistor. This component is quite cheap and can be easily obtained from those used/junk electronic boards especially boards that have the Optoisolator IC in it. What happens to the power supply if this component is shorted or leaked? It would cause power blinking/cycling, low power or even intermittent no power problem.

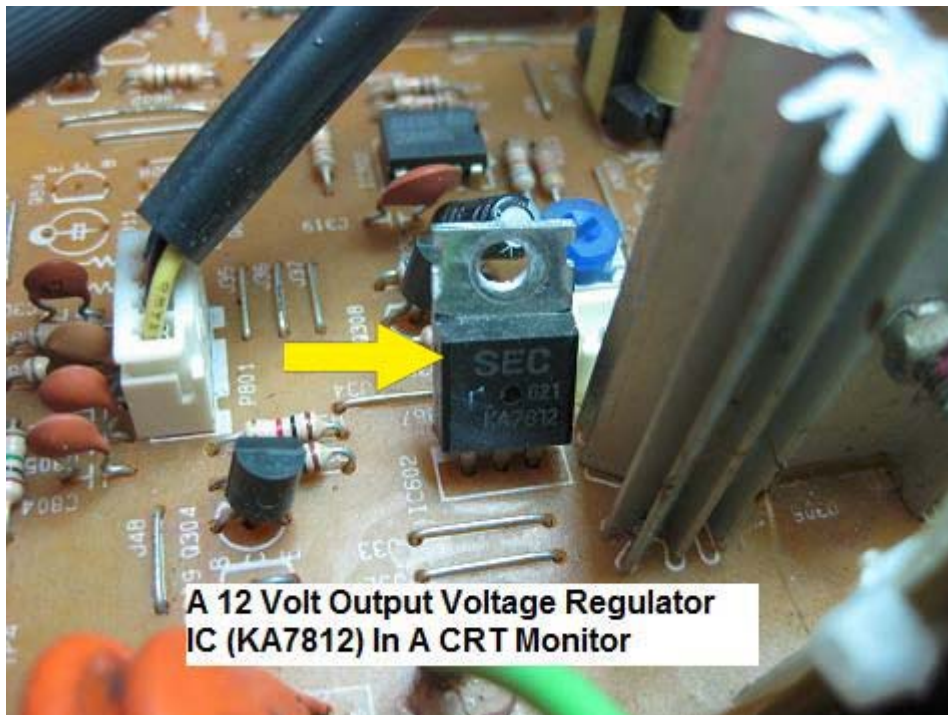
## 22) Small Preset



**Figure 5.30- A Preset In Secondary Side Of SMPS**

Small preset (potentiometer) (**board location marked as “VR”**)- The function is to control the overall output of the SMPS. They are mainly located at the secondary side near Optoisolator and TL431 IC but in some design you could see them at primary side. Some newer SMPS do not have the preset anymore and the manufacturers have to put in a **four or five colour bands resistors** as a replacement for the preset. The common faults for preset are open circuit and erratic problem and this could cause no power, power blinking/cycling and intermittent power problem.

## 23) Voltage Regulator



**Figure 5.31- A Voltage Regulator IC**

Voltage regulator (**board location marked as “IC”**) – The function of a voltage regulator is to keep the output voltage steady, **in spite of changes in the load**. For your information the input voltage must have at least two volts higher than the output voltage. That means, if you want to get a 5V output from a 7805 voltage regulator, the input voltage has to be at least 7V and above. Don't expect to use a 3V dc input to produce 5V output, this way it would not work! If this IC is bad, it would not produce any output (have input but with zero volt output) and also the output voltage may drop to a lower value.

Conclusion- Please note that although I have explained all of the possible problems in the electronic components used in the power supply, one has to know the fact that there are **many types of SMPS** in the market. Thus I want you to be flexible especially in repairing different kind of SMPS. Some may use Optoisolator IC and some may not, some may have signal diodes and some may not have, some have SCR transistor and some don't, some use surface mount device (SMD) in the circuit and etc. It all depends on the designers what he or she would prefer to use in the power supply circuit. What you need to do is to check and replace any shorted components; fix any cracked solder joints, reassemble and test the SMPS.

## **6) How to Find The Right Equivalent Components In SMPS Circuit**

Troubleshooting and repairing SMPS can be fun but you will get frustrated if you could not locate the spare parts. Sometimes the SMPS repair job can be done in a few minutes. However, when finding the original parts, you may end up spending more time to locate the parts than when you do the repair work on the SMPS. In order to make things easier, I will share with you how SMPS could still work even without the original part numbers and you have to take your own risk when you are following my methods. If you want to find some spare parts for SMPS, you may visit my blog at <http://www.JestineYong.com> under the category of “Electronic suppliers to get the components you want.

**Note: Always use original part numbers for replacement purposes!**

**Main Fuse**-Normally manufacturers installed a slow blow fuse with the fuse rating of 2 Ampere to several Ampere in SMPS. If the fuse rating is a 3 Ampere, you can always replace one with a higher Ampere like 3.15 Ampere and not 10 or 20 Ampere fuse. If possible get back the same ampere and volt rating of fuse. Please don't replace with a 3 Ampere **fast blow fuse** as it may not last long and please **do not put in a wire** as a replacement for the fuse as it **will cause fire!** For your information a slow blow fuse price is much more expensive than the fast blow fuse.

**Varistor**- Not all SMPS has Varistor in the circuit, assuming that you have come across one burnt or shorted Varistor. You have the option to replace with a new one or just remove the Varistor from the circuit. After the removal of the Varistor, the SMPS would still work except that the SMPS no longer has resistance toward surge in the days to come. These are the risks that you are going to take if you have decided not to put in a new Varistor. Probably you want to save cost or you just could not locate the original or equivalent part number for Varistor.

**RFI Filter**- This circuit consists of coils and capacitors. The capacitors seldom have problem except the coils. If there was a heavy surge, the coils might burn. Some coils could break and you can join back the wires with solder. You can also easily find a replacement from other junk electronic boards and if you really could not find one you could just directly solder a jumper across (a wire) the two connections and it should

work but of course this has defeated the purpose of the RFI filter circuit function.

**Negative Temperature Coefficient (NTC) Thermistor** – For your information not all SMPS uses the NTC. If it is bad and if you really can't get the part, the only choice you have is to replace it with a jumper wire. The consequence is the SMPS has no protection against high inrush current anymore. Before you send the SMPS back to your customer, you need to test (switch "On" and "Off") many times to really make sure the SMPS is stable and would not blow the fuse. Otherwise I guess you may need to put in the NTC to avoid the fuse blow problem.

**Bridge Rectifier** – Some SMPS designs use the package type while some use four individual diodes. Assuming you found one of the four individual's diode shorted you have to replace all of them together otherwise the other three somehow will fail later. As for the package type, you can easily get an original part number from any electronic suppliers. Now assuming that you can't get the original bridge rectifier, you can actually fabricate one, using four individual diode as shown from figure 6.1.



**Figure 6.1- Typical Example Of A Fabricated Bridge Rectifier From Four Individual Diodes.**

If you want to get the diodes, look for the specifications that have the same or higher rating in terms of Voltage (Peak Reverse Voltage-PRV)

and Ampere (A). These two part numbers are most commonly used in the consumer electronics SMPS ie; 1N4007 (for smaller size of equipment) and 1N5408 (for bigger size of equipment).

**Filter capacitor** – All of the SMPS must have at least a big filter capacitor to remove the ripple from the line. Depending on the application, their value ranges from 68 to 470 microfarad, 400 to 450 Volts. Now assuming you have found a bad filter capacitor with a 150 microfarad 400V, you can always use a replacement with a higher microfarad with the same or a higher working voltage like 220 microfarad with 400 or 450 Volt. This is also true for filter capacitor in the secondary output side. You may use a 1000uf capacitor to replace a 470uf capacitor but of course the working voltage has to be the same or higher.

**Please do not use any replacement that has smaller capacitance value and lower voltage than the original one. Otherwise the equipment may not work and in worst cases, it could blow up the capacitor.**

**Resistor** – In SMPS, resistor value has to be accurate as a small change in the resistor value could cause problem in the output. Let's take the current sense resistor as an example. The common value for current sense resistor in CRT Monitor SMPS is 0.33 Ohm. If you replace this resistor with a 0.47 Ohm resistor or higher, the output power would drop to half! **Replace the current sense resistor with only the same Ohm value and the same type of resistor.** Finding resistors is not a problem as many electronic suppliers do carry this part. Another questions like “Could I replace the resistor that have ½ Watt with a 1 Watt resistor?” The answer is **YES** but don't replace it with a 5 or 10 watt resistor as this is not economical and the SMPS may not work and also it doesn't look professional if the SMPS falls into the hands of other electronic repairers. You can replace the resistor with a Watt higher than the original one like 1 Watt with 2 Watt, 5 Watt with 7 Watt and etc.

**Non polarity capacitor-** Get back the same capacitance value as the original one and you could use other types and not necessary the same type of capacitor. If the capacitor was a resin type capacitor, you could replace it with a ceramic type but the value has to be the same.

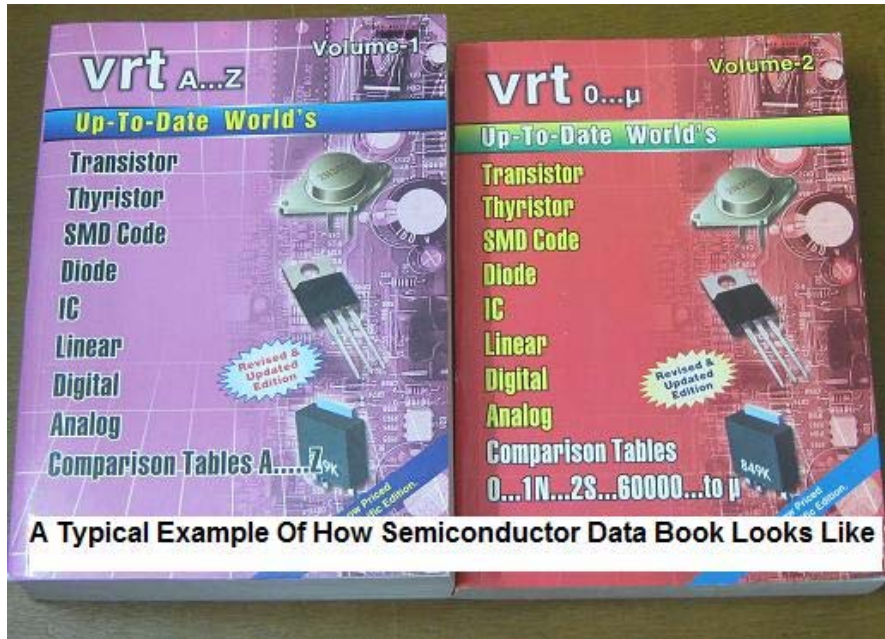
**Zener Diode** – Zener diodes can be easily obtained from any electronic suppliers. If possible get the same exact voltage rating but the Watt size can be the same or higher. If the original one is an 18V ½ Watt Zener diode then you can get an 18 Volt 1 Watt Zener diode as a replacement.



Don't use a lower Wattage Zener diode as replacement. Assuming you are in a hurry in getting the SMPS working again and you do not have a 5.1 Volt Zener diode in your spare part compartment, the only choice you have is to connect two Zener diodes series just like when you are connecting dry cell batteries. Connect a 2.4 Volt and a 2.7 Volt Zener Diode from cathode to anode will give you a value of 5.1 Volt!

**Diode-** This is the same as Zener diode where you can get the original parts from any electronic suppliers. **You can replace one with the same or higher Volts and ampere.** For example, a 1N4004 can be replaced with a 1N4007. Now, many technicians are confused about the part numbered 1N4007 (general purpose diode) and the UF4007 (Ultra fast recovery diode) and in fact many electronic suppliers labelled them as from the same type. Ultra fast recovery diode is different from general purpose diode because they are made to handle the very fast switching action of the power supply. If the original one was an ultra fast recovery diode and you replaced it with a general purpose diode, the moment you switch "On" the SMPS, the general purpose diode would immediately go shorted (due to their higher switching losses and subsequent thermal stress) or blow! Insist in getting the original part number from the electronic suppliers. By the way this explanation can also be applied if you want to find replacement part number for Schottky diodes used in ATX power supplies or in any other electronic equipment that have the SMPS in it.

**Bipolar transistor-** Common part numbers like C945 and A733 transistors can be easily found from any electronic suppliers. If you come across one that you can't find from any electronic suppliers then the only option you have is to use an equivalent part number.



**Figure 6.2- A Typical Semiconductor Data Book**

Please refer to any semiconductor data books to search for the replacement. In some data books, there would be suggestions as to which part numbers are suitable for replacement. This kind of data book is a must for any one who works in the electronic repair line. Apart from that, you could also find your own replacement by comparing the specification between the original and the replacement transistor. Always look for the replacement that has the same or higher specification in terms of Voltage, Ampere and Wattage.

Manu	Comparison Types
Say	2SC4891, 2SC5045, 2SC5252
Say	2SC5300, 2SC5516
n) Say	2SC4840, 2SC5091
n) Say	-
Mat	-
n) Rhm	-
n) Rhm	-
n)	<b>Comparison Types Means Replacement Part Number</b>
n) Hnm	-

**Figure 6.3- Comparison Part Numbers Found In The Semiconductor Data Book**

If you do not have the data book, you can always search the Internet and compare the original specification with the replacement one but of course this would take you more time

**IGBT/SCR-** As for these devices please refer to the bipolar transistor explanation on how to find the equivalent part number.

**Power IC-** Although it is always recommended to replace the power IC with the original part number, in fact if you carefully study the internal specification of the power IC (assuming if you have the datasheet downloaded from the internet), you could actually get a replacement. For example, the part number of DP104C can be replaced with a DP704C IC. I've done that many times in repairing SMPS in Samsung CRT Monitors. Another example was that I used UC3844 PWM IC to replace the original UC3842 PWM IC and it worked fine. But this replacement only can be done on certain type of brand of Monitor SMPS. I do not know what type of SMPS you are repairing but if you do your homework, I believe you may get the replacement for your type of SMPS.

Although there are some successes in finding a replacement of Power IC, I came across a problem with replacement of power IC as well. The original part number is TDA1504 and was replaced with TDA1504AP. Not only the SMPS did not have power, it blew up the power supply and burnt lots of components in it. With an additional of the word "AP" after the part number makes lots of difference.



**Figure 6.4- Insist on Getting The Same Part Number Especially The Power IC**

**Note: If possible please replace the Power IC with original part number to avoid power shutdown, no power, low power or even intermittent power problem.**

**Field Effect Transistor (FET)** – There are lots of different part number for FET's used in the SMPS. In fact every new model of SMPS in the market uses the latest part number. This has caused us the “repair” technicians sometimes to have difficulties in tracing the part specification. Many times you can't even get the FET information from the Internet because the part number is still new (latest version). Back in the early 90s most of the CRT Monitor used FET part number starting with K791, K792, K793 and etc but now it is common to see part number that starts with K2645 and higher. In fact some of the latest SMPS already used the part number that starts with K3000 series and higher. Due to the fact that sometimes it is quite hard to get the exact part number, the only choice we have is to find a replacement part number from semiconductor data book.

Do you know that one can always use a universal part number to substitute on some particular SMPS? I have used K1118 to substitute for all kinds of FET's part number found in any 14 and 15” CRT Monitor. For a 17” CRT Monitor I will use K2645 as a universal substitution. This part number can be used on all 15” till 19” LCD Monitors as well. First you have to understand the specification of the FET's used in your type of equipment (SMPS). Find out the Volt, Ampere, Wattage and the Ohm value and by referring to a semiconductor data book I'm sure you will get the right substitution part number that **can support your type of SMPS**. The specification ratings have to be the same or higher than the original part number except for the Ohm value spec where you need the same or lower Ohm value.

**Switch Mode Power Transformer (SMPT)** – There's no equivalent SMPT in the market because every SMPT are created unique in terms of windings. Some SMPT have two outputs while some have many outputs. Not only the total number of output differs, the volt and amps produced are also different. The only way you can get is through the equipment distributors and don't be surprise as some may not have the stock for SMPT. Some electronic distributors may keep some stock for SMPT but nowadays you can hardly find one. Another option is to send the SMPT for rewinding. Do compare the cost of the rewinding with the new unit of the SMPS and if the rewinding cost is too high then get a new unit of SMPS instead of rewinding.

**Secondary Output Diodes** – Output diodes are a common failure in the switch mode power supply. Please refer to page 89 for diode replacement.

**Secondary Output Filter Capacitors**- Output filter capacitors are a common failure in the switch mode power supply. Please refer to page 88 for filter capacitor replacement.

**Secondary Output Coils** – If the secondary coils are small, you can replace it with a jumper wire. However, if the secondary coils are big like the B+ coil in the CRT Monitor circuit, you have to get back the same inductance value. You can rewind your own coil by removing out the burnt wire. Measure the length and the diameter of the original wire then wind it back using new wire to its ferrite core.

**Optoisolator IC** – By referring to datasheet downloaded from the Internet; you can find equivalent part number for it. The famous 4N35 part number can be easily substituted by many other Optoisolator IC part number. This 4N35 IC is quite common and can be easily found from any electronic shops.

**Adjustable Precision Shunt Regulator**- You have to use back original part number as there is no replacement for this IC. The famous part number for this IC is TL431. Some come with other version of part number like S431, 431 and etc.

**Small preset**- Use back the same resistance value as it is easily available from any electronic suppliers.

**Voltage Regulator**- There are many manufacturers manufacturing this type of voltage regulator IC's, thus their part number may differs a little but it can be used anyway like 7805, L7805, LM7805, KA7805 and etc. These components are just like the small preset which you can easily get from any local electronic suppliers.

After reading this chapter I'm very sure that you are now ready for any SMPS troubleshooting and repairing job.

PART II

**Secret of SMPS  
Troubleshooting  
Techniques**

## **7) Recommended Tools and Test Equipment For Successful SMPS Repair**

In order to successfully repair any electronic equipment which include the SMPS, one must have the necessary tools and test equipment in their repair bench. By depending only on a multimeter, it would not be enough to solve your electronic problems. For your information, test equipment was designed to test on only a few specific components and not all components. Obviously you can use a multimeter to test a wide range of electronic components but do you know that some electronic components like electrolytic capacitor can be tested good using multimeter but failed when tested by a specialize test equipment like the Blue ESR meter?

If you wrongly judge an electronic component, the rest of your troubleshooting time **would be wasted**. Let's take this for example-if the problem in the SMPS was caused by a defective capacitor in the secondary section but your multimeter stated that all the secondary electrolytic capacitors were good that means **you will be wasting your time in finding fault in the primary section**. The problem is in secondary side and not in the primary side!

From my experience, if you want to be good in solving electronic problems (simple or complicated problems) you must get the tools and test equipment that I'm going to share to you afterward. Your investment on the tools and test equipment will **pay itself back** in a very short period, provided if you have lots of equipment (SMPS) for you to repair. The days are gone where one has to guess whether a component is good or bad. By using the right meter, you will surely know if the component is good or bad and you will also have the speed in solving things fast! In the next page you will find the tools and test equipment that you would need in order to repair SMPS.

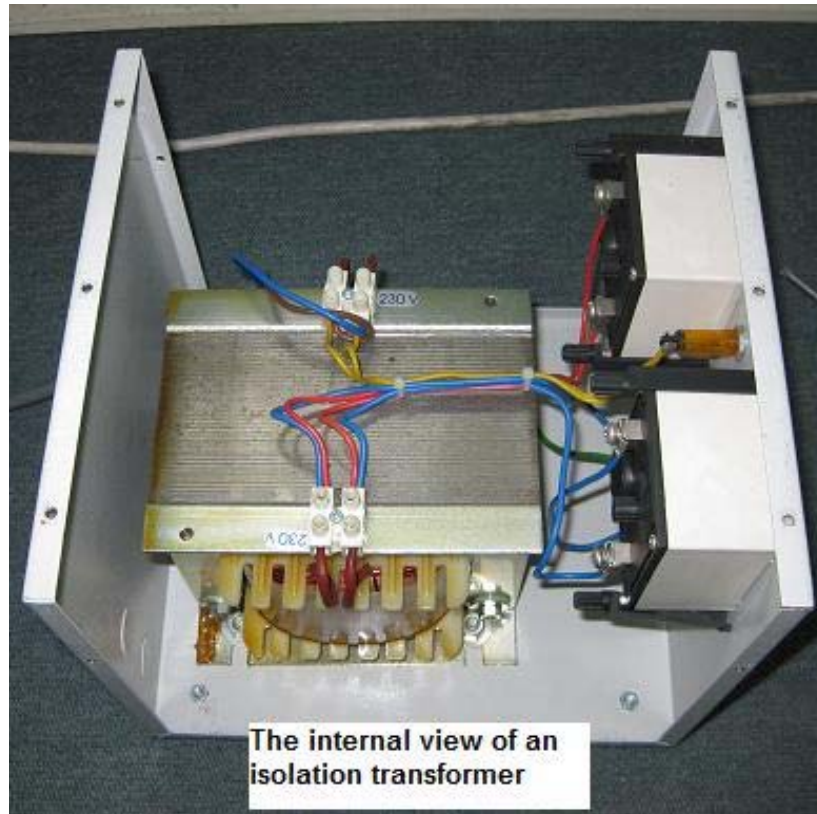
## 1 Isolation Transformer



**Figure 7.1- Isolation Transformer**

Be aware that the disadvantage of switching power supply is that they can be very dangerous to work on! This is because the hot side of the AC line essentially goes to all power supply components on the primary side of transformer. If you accidentally touch anything in this primary power side circuit and ground at the same time, there would be a path for electricity to flow through your body and you could receive a severe electrical shock.

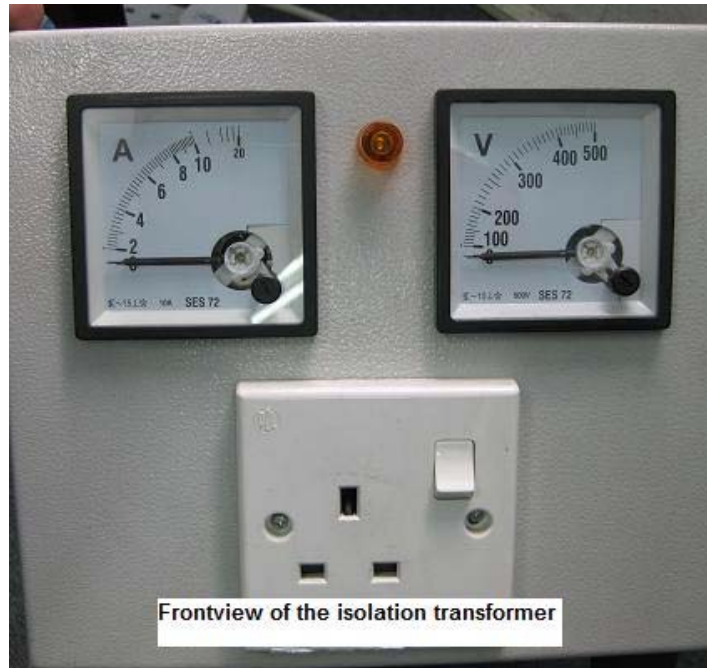




**Figure 7.2- Internal View Of Isolation Transformer**

When servicing any electronic equipment which includes the SMPS, always use an isolation transformer to protect yourself from an electrical shock. During servicing, the isolation transformer is connected between the equipment and ac power line. An isolation transformer is a transformer that has a 1:1 turn ratio to provide the standard line voltage at the secondary outlet. This means that it does not change the voltage. The transformer still produces 240V AC (or 120 VAC in USA and etc) at its outputs, but both sides of this AC lines are independent of ground.

That means there is no direct electrical connection between the primary and secondary windings. If you were to accidentally touch one of these outputs, you would be protected because there is no ground reference. The isolation transformer must be rated to handle the power of any equipment connected to it. Typical ratings are 250 to 500VA. You can also get an isolated variable transformer as seen in page 99.



**Figure 7.3- Front View Of Isolation Transformer**

## **2 Variable Transformer**



**Figure 7.4- A Typical Variable Transformer**

The variable transformer or Variac is one of the most versatile electrical control devices ever invented, providing essentially undistorted variation of AC voltage. I use the Variac to control the AC voltage to the SMPS for troubleshooting purposes. Some electronic problems could surface even at low voltage (20 TO 30 VAC) and not necessary you must apply the full AC voltage to the SMPS.

For your information, some Variac comes with a built in AC ammeter while some do not have. The one that I'm using does not have the AC ammeter and I have to connect the AC ammeter externally and the variable transformer that I had have the specification of 1 KVA with adjustable output voltage from 0 to 250 VAC. Please refer to page 100 (AC ammeter) on how variable transformer can help in troubleshooting and repairing SMPS.

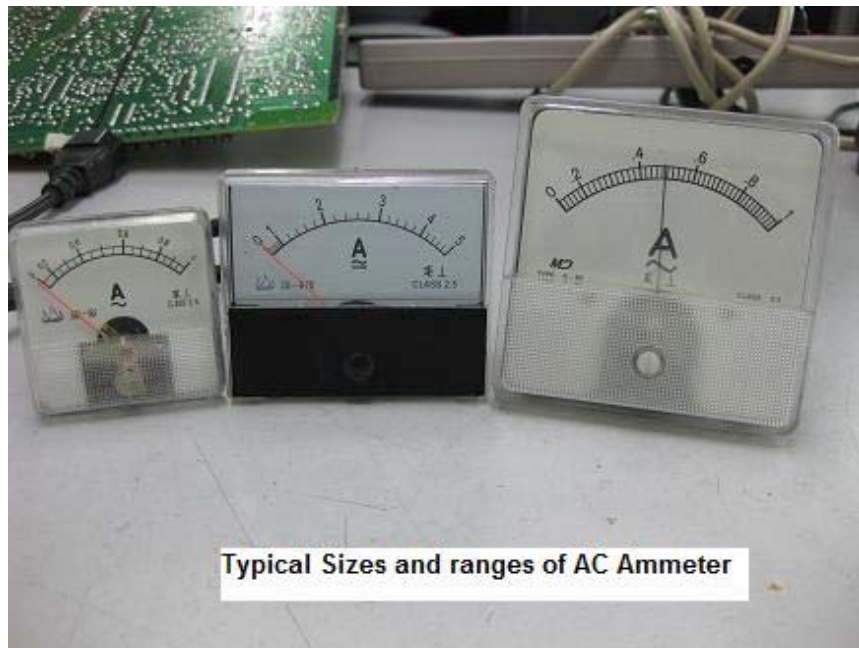
***Note: A variable transformer or variac is not an isolation transformer.***

However you may get an isolated Variac from Tenma dot com that have the built in panel voltage and ampere but the voltage range could only go up to maximum 145 VAC as seen from the photo below. This product is most suitable to the country that uses a 100 to 120 VAC in the Main line like the USA, JAPAN and etc.



**Figure 7.5- Tenma Isolated Variable AC Power Supply**

### 3 AC Ammeter



**Figure 7.6- Typical AC Ammeters**

The reason we need an AC Ammeter (analog or digital) is to find out if the substitution part that we have replaced is problematic or not.

Assuming you have replaced the secondary diode with another part number and you do not know if the replacement diode can last or not, you can use AC Ammeter to monitor the current. If the pointer of the 1 AMP AC Ammeter slowly moves up, you will know that the replacement diode is not suitable to use.

If the pointer stays at a certain range (usually at low scale) and does not move up even after many hours, this indicates that the replacement diode can be used for substitution. This would surely save your time as otherwise the customer may call you back after awhile by telling you that the repaired SMPS is faulty again. Your reputation and your profits might be affected.



**Figure 7.7- One Ampere AC Ammeter**

Besides using the AC ammeter to monitor the current drawn, you may also use it as a **troubleshooting tool** to locate a shorted component. How? Let's assume that a customer complains that a SMPS has no power symptom. You found out that the main fuse and the bridge rectifier are faulty. When you replaced both the components and thought the SMPS would work again but the FUSE immediately blow upon being switched "On". In order to avoid this problem you can in fact **slowly bring up the AC voltage to the SMPS by using the variable transformer**. If there is a shorted component in the power supply circuit, the AC ammeter pointer would begin to increase very fast indicating there's a problem.

After bringing up the AC voltage to about 20 to 30 volts, stop the adjuster of the variable transformer and wait for a few minutes and then remove the AC cord from the SMPS and quickly place your finger on the power supply area. **If you noticed any electronic components that are very hot, then that component is the cause of why the fuse blow-isn't this a great tool for troubleshooting SMPS?**

**Note: I would like to repeat that do make sure the AC supply is not connected to the SMPS when you want to put your hand on the parts! By the way you don't need to discharge the big capacitor because you have increase the AC voltage to about 20 to 30 Volts only. However, if you feel that you want to discharge the big capacitor before you touch on the components, you may do so. Please**

refer to chapter 17 for more information on how to use the AC ammeter.

#### 4 Analog and Digital Multimeter

There are two types of multimeters in the market; namely one is the analogue while the other is the digital. Some people call them multimeters or just meters, while others might refer to them as volt ohm meters (VOMs) or multitesters. Regardless of which name you choose to call them, multimeters are the handiest and most versatile piece of test equipment that you will ever use.



**Figure 7.8- An Analogue Multimeter**

The analogue meter can measure ac and dc voltage, current, and resistance. A digital multimeter (DMM) performs the same functions, but it produces a digital display. DMM are ranked by the number of digits they display. A “3½ digit” DMM will indicate three numbers for each reading. The “half digit” is reserved for character like “+1” or “-1”. The more sophisticated meters automatically choose the correct voltage or resistance range. This feature is called “auto-ranging”. DMM are easier to read, more tolerant of operator error, and more precise than their analogue multimeters.



**Figure 7.9- A Digital MultiMeter**

A good DMM also includes features like a capacitance checker, frequency meter, continuity checker and transistor checker. The diode setting is used for checking all solid state devices such as diodes, transistors, SCRs and so forth.

I would not touch more on this topic because I assume that you already know how to use multimeter and test electronic components. However if you want to become better in using multimeter to test electronic components you may visit my website at <http://www.TestingElectronicComponents.com>

## 5 Digital Capacitance Meter



**Figure 7.10- Digital Capacitance Meter**

Without a capacitance meter, it is difficult to determine a capacitor's value. Choose a capacitance meter that accurately measures the value of any capacitor between 0.1PF to 20,000UF. Capacitance meter will usually display capacitance in microfarad (uf), Nano farad (nf) or Pico farad (pf). As long as your reading is within the tolerance of the capacitor's marked value, you know the part is good. It is best used to check fixed capacitor (ceramic, Mylar, etc). **For electrolytic type of capacitor, a Blue ESR meter is preferred.** Some DMM are also equipped with a built-in capacitor checker. Always discharge a capacitor before testing.



## 6 Blue ESR Meter



**Figure 7.11- A Blue ESR Meter**

Almost all electrolytic capacitor failures are due to high ESR (Equivalent Series Resistance). The high internal resistance reduces the capacitor's rate of charge and discharge effectively, making it an "open" capacitor. High ESR is usually a result of dehydration of the electrolyte due to equipment heat, old age, corrosion, defective rubber seal and high ripple current.

High ESR in electrolytic capacitors causes various problems. In power section of any electronic equipment, they can cause no power problems or even power blink. In the color or video circuits of Monitor or Television, they cause intermittent or missing colors.

The job of finding any high ESR in electrolytic capacitor is done by the ESR meters. **Note that ESR cannot be measured by a digital capacitance meter or a multimeter.** It has to be measured by the ESR meter. ESR meters come in all shapes, sizes and brand. We found that a unit called Blue ESR meter designed by Bob Parker to be the best value for our repair shop. Blue ESR meter is a powerful ESR meter, user friendly, robust, versatile and capable in locating bad or shorted electrolytic capacitor while still in the circuit. Please visit the link at page 106 to find out the capabilities of using Blue ESR meter to test on other

components besides electrolytic capacitors  
<http://www.electronicrepairguide.com/esr-meter.html>

This meter is a “**must**” if you are serious in doing the electronic repair work.

## 7 Blue Ring Tester



**Figure 7.12- A Blue Ring Tester**

Using an ohmmeter (analogue or digital multimeter) or even an inductance meter to test a coil/winding will give you an inaccurate result. Why? Because both meters (ohmmeter and inductance meter) could misled you into believing that the coil/winding is good where in fact the coil/winding is shorted internally between windings! Your precious time will be wasted because you could not effectively locate the bad component (which is the coils). Now thanks to this simple yet a powerful tester to really test out the coils/windings that have shorted turns especially the **primary winding of switch mode power supply**.

This Blue ring tester is an inexpensive yet effective way to test any high Q inductive component. It is especially useful for doing a quick check on **SMPS Transformer, Flyback Transformers, Monitor B+ coil, Ballast**

**Choke and other high frequency inductive components like deflection yoke windings.**

Another good reason you should get this blue ring tester is that it has the **capability to perform in circuit test.** If you are familiar with the equipment you are repairing and this will surely save your time without having to remove coils from the circuit. Otherwise, you may need to solder out one leg to test the coil. The test leads are non-polarized-that means you can test the coils using either way from the test probes.

Please read chapter 14 **“The Five Methods That I Use to Troubleshoot and Repair SMPS”** to see how I use the Blue Ring Tester in troubleshooting power supply. For more information about Blue Ring Tester you may visit <http://www.electronicrepairguide.com/blue-ring-tester.html>

## **8 Oscilloscope**



**Figure 7.13- An Analogue Oscilloscope**

Oscilloscopes offer a tremendous advantage over multimeters. An oscilloscope or “scope” can give you a “picture” of a changing electronic signal. Instead of reading signals in numbers or lighted indicators, an oscilloscope will show voltage versus time on a graphical display. Not only can you observe ac and dc voltages, but they are also very helpful for checking the “shape” of an electronic signal. If you know what kind of signal to expect, and the scope shows you a different signal, you know something is wrong. The scope can be used to check the operating characteristics of parts like transistors and capacitors. Oscilloscopes have been used for many years to troubleshoot power supply, amplifiers, and other analogue devices.



**Figure 7.14- A Digital Oscilloscope**

Don't get the idea that you will need an oscilloscope for every repair. For example, you need to check the presence of output waveform of a power IC. It is also useful in checking the secondary output lines to see if there are any ripples or not.

Without an oscilloscope, it is difficult or almost impossible to trace those important signals in SMPS. The higher the frequency of the scope the more expensive it is. Oscilloscope of 50 to 100 megahertz (MHz) bandwidth will serve you well. Some "dual trace" scopes can display two signals at once. This allows you to compare the timing relationship of two related signal. If you have used an oscilloscope before, then you probably know just how useful they can be.

For more information about using oscilloscope for troubleshooting purposes, please go to chapter 12 on "How to Use Oscilloscope to Test SMPS Circuit waveforms".

## 8) Safety Guidelines



**Figure 8.1- A Danger Sign**

Whenever you're working on the SMPS, your own safety has to come first. Every electronic technician must always take safety precautions before he or she starts work. Electricity must be handled properly, or else it can injure or cause fatalities. Here are some basic steps that show you how to avoid accidents from occurring.

### 1. Electrical Shock

Once you open up the SMPS cover, you're actually exposing yourself to the threat of electric shock. Always keep in mind that safety has to come first. A serious shock may stop your heart and if a large amount of electric current flows through your body, you will receive serious burns. Here are some rules, which should help you to avoid electricity hazards.

- a) Always turn off the SMPS and unplug it before you begin to work.
- b) If you have to run tests while the equipment is operating, turn the equipment on, make your test carefully, and then turn the equipment off again.
- c) Wear rubber bottom shoes or sneakers.
- d) Try to do the work with one hand, while keeping the other in your pocket. That keeps the possible current paths away from the heart.
- e) Don't attempt repair work when you are tired or rushed.
- f) Always assume that all the parts in the power supply are "**HOT**".
- g) Use only plastic screwdriver for shock protection during service operation.

## **2. Discharging Switch Mode Power Supply (SMPS) Capacitors**

Most SMPS have a resistor to drain the charge in the main filter capacitor. But some resistors may fail and the capacitor can hold this charge even after you have turned off the equipment. This capacitor has a range of about 150uf to 330uf at 200 to 450 working voltage.

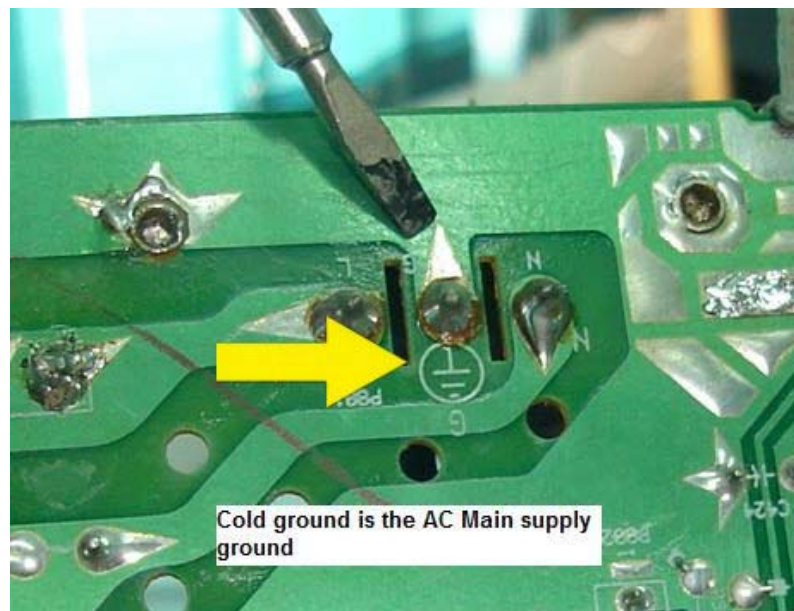
Before you start to work on a power supply, always turn off the power and discharge the capacitor. You can do this by placing a resistor across the two legs of the capacitor. The resistor value can be around 1.8 to 2.2 kilo ohms 10watt. It takes only a few seconds to fully discharge a capacitor. Double-check the capacitor with a voltmeter after every discharge.

### ***NOTE / WARNING:***

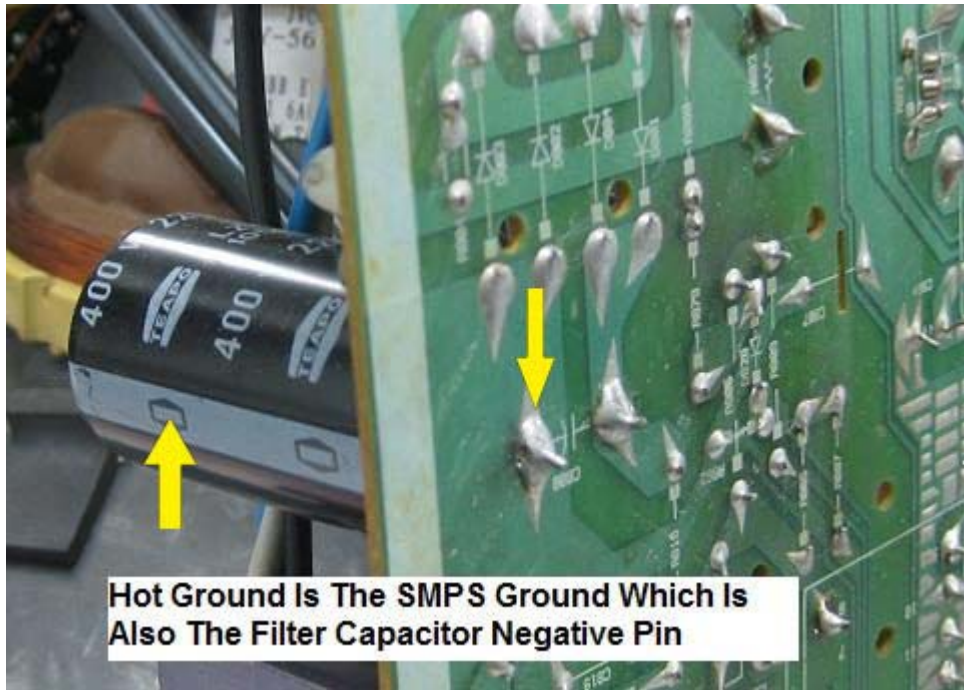
Do not discharge capacitor with screwdriver because: -

- i. It may melt the tip of the screwdriver.
- ii. It will damage the capacitor and its terminal.
- iii. If we are too near to the point of discharge, the heavy spark generated may cause injury to our eyes.

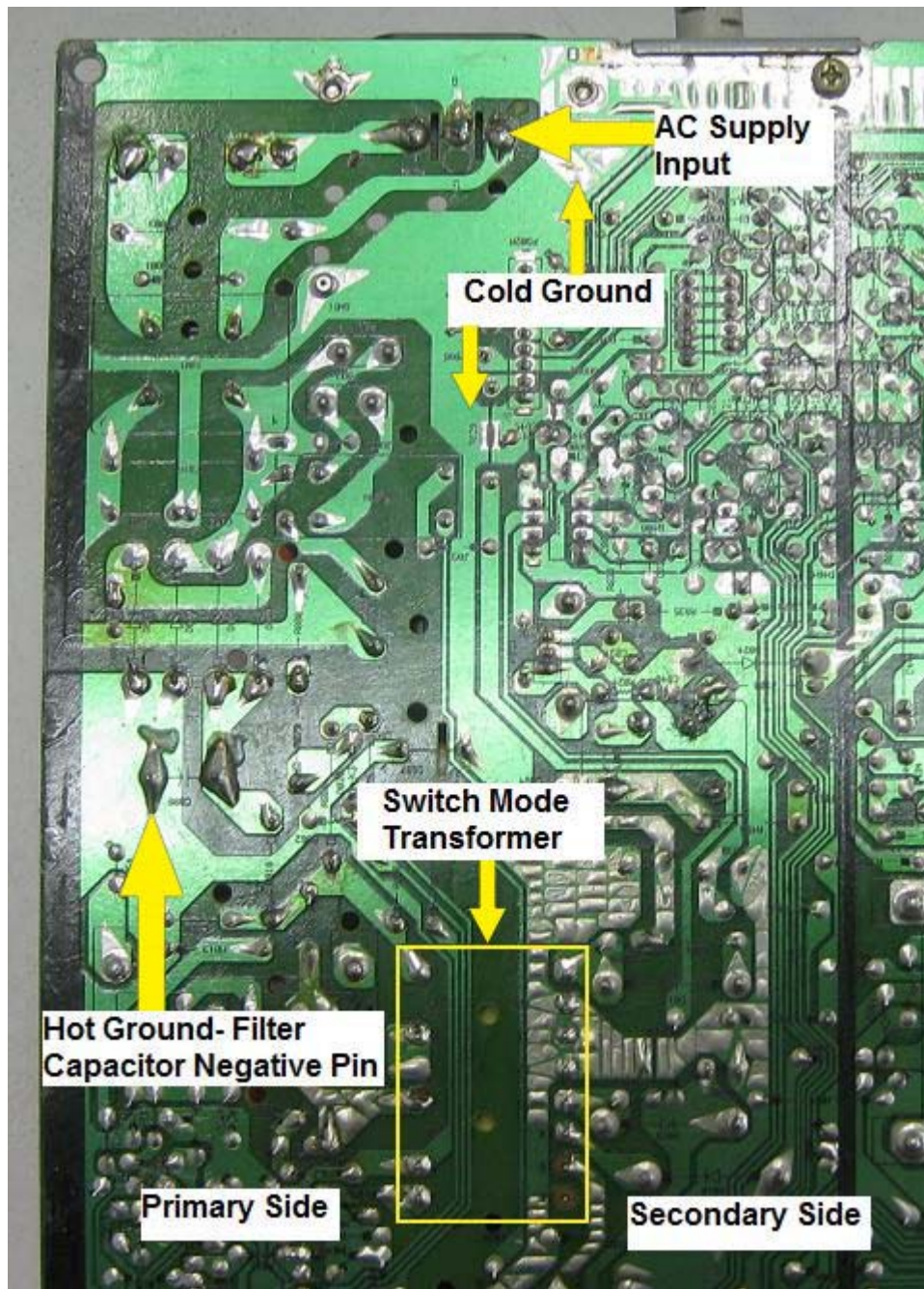
## **3. Hot Ground Problem**



**Figure 8.2- Identifying Cold Ground In Circuit Board**



**Figure 8.3- Identifying Hot Ground In Circuit Board**



**Figure 8.4- The Difference Location Of Hot And Cold Ground In Electronic Circuit Board**

SMPS consists of two grounds, one of which is a “hot” ground while the other is a “cold” ground. Hot ground is in the primary side of a switch mode power supply while the cold ground is the equipment ground and located mostly at the secondary side.

Be careful when taking voltage measurements around these grounds. **For example, if you want to check the primary circuit of a power supply with power on, always ground your meter (black probe) or scope to**



**the hot ground, while checking the secondary side then you have to connect the black probe to cold ground.**

If you want to test the primary side of SMPS and you accidentally connect the black probe to cold ground, the voltage measurement might not be correct and sometimes it may destroy your meter. One way to prevent this is to use an “isolation transformer”.

#### **4. Isolation Transformer**



**Figure 8.5- An Isolation Transformer**

The use of isolation transformer can be found at page 96.

## 5. Electrostatically Sensitive Devices (ESD)



**Figure 8.6- A Wrist Strap**

Integrated circuits (IC) & some field-effect transistors are examples of ESD devices. These components can be easily damaged by static electricity. There are several techniques which can reduce the incidence of component damage, caused by static electricity.

- a) Immediately before handling any ESD devices, drain the electrostatic charge from your body by touching a known earth ground.
- b) Store ESD devices in conductive foam pad until installation in circuit.
- c) Wear a grounding strap and attached to your wrist.
- d) Use only a grounded tip soldering iron to solder or desolder ESD devices. (Some suggest using a battery powered soldering iron when working on ESD circuits).

## 6. Fire

Before returning the equipment to the user, every reasonable precaution is taken to avoid fire hazards. Be sure to use only direct replacements and not one that defeats some safety measure. For example, the fuse in your equipment is carefully designed and it **must be replaced only with the same size, type and ratings**. Should you install a fuse that is too large than the original rating, chances are that the equipment will be flammable.

## **9) Understand The Six Common Problems Found In SMPS**

No matter what type of power supply you are repairing, I can say that almost all of the power supplies problems fall into these six categories:

1. No power
2. Low output voltage
3. High output voltage
4. Power Cycling/Blinking
5. Power Shutdown and
6. Intermittent Power Problem

Once you have understood the common problems in SMPS, you then can use the necessary steps to isolate, troubleshoot and repair the SMPS. For a successful repair you must first test the power supply with power “On”. Look at the problem carefully before you start any troubleshooting work. I don’t want you to waste unnecessary time by repairing the SMPS when the actual fault is intermittent power problem and you treat it as no power problem! In other words-**please don’t misdiagnosed!** Even if it takes you a longer time to inspect the faulty SMPS-the time will be well spent! Ask your customer what is the problem with the SMPS. Once you got the picture, you will easily diagnose the fault based on the tips that I’m going to share with you in this topic. Let’s begin:

### **1. No power**

No power in SMPS tends to fall into these two categories:

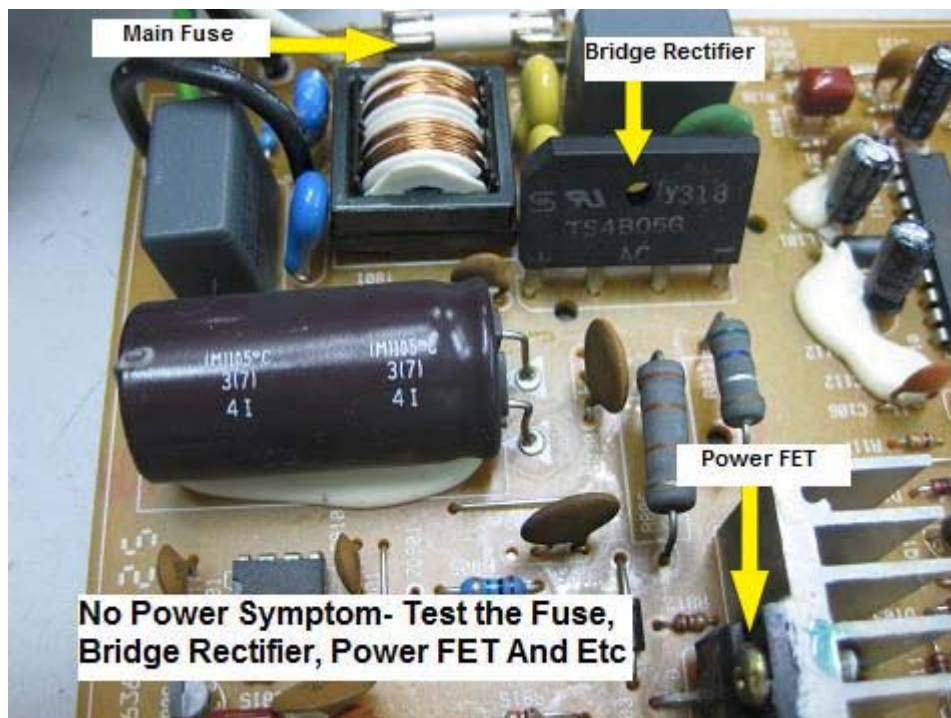
- a) **Dead and silent with fuse blown**
- b) **Dead and silent with fuse good**

It is very easy to identify the no power problem. Switch “On” the equipment or SMPS (make sure that the AC power cord is properly connected) and look at the power LED light indicator in the front side of the equipment. If there is no light and does not have any rushing sound (normally for a TV or Monitor you could hear a sound upon switched “On”) chances are high the equipment has a no power symptom.



**Figure 9.1- The LED Act As A Power Indicator**

Open up the cover and first look at the fuse and test it with your ohmmeter. If it is bad (**dead and silent with fuse blown**) then go further to test the bridge rectifier, power FET, Secondary diodes etc to see if the components have developed any short circuit or not.



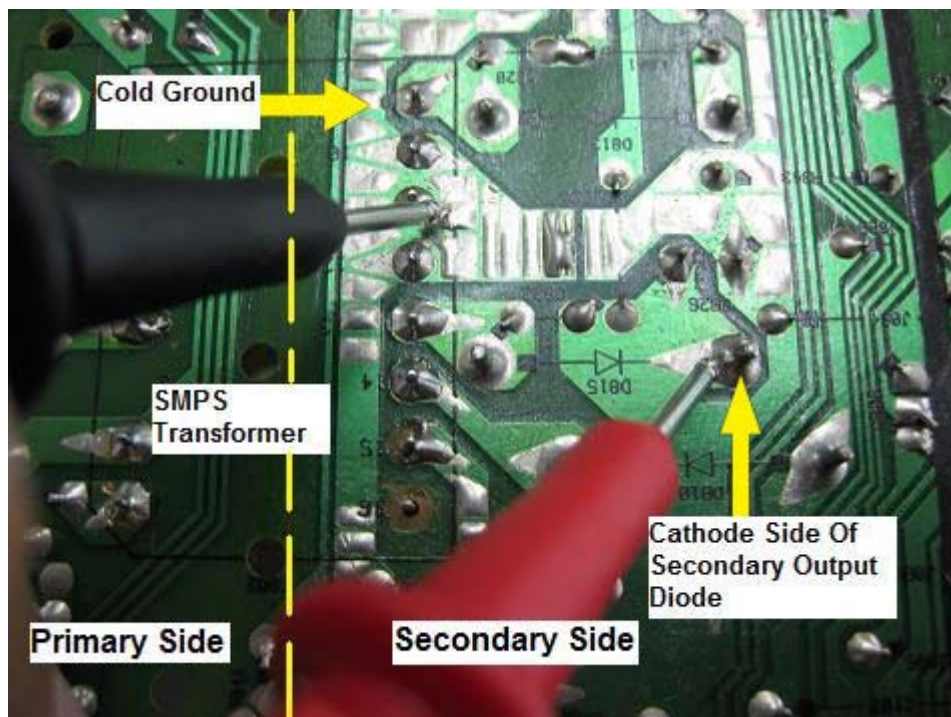
**Figure 9.2- Basic Way Of Fault Finding**

**Note: Sometimes the fuse can blow by itself due its life span. Please refer to fuse topic on chapter 5 “Electronic Components Found In SMPS and Possible Causes” for more information.**

Sometimes the fuse can be tested okay (**dead and silent with fuse good**) and the problem could be in the On/Off switch and you can use an ohmmeter to test it out. If the fuse and the On/off switch are tested okay, then I suggest that you go to chapter 11 on “**How to Easily Perform Voltage Testing On SMPS Circuit**” as voltage testing is one of the best ways to solve the “**Dead and silent with fuse good**” problem fast.

## 2. Low output voltage

It is easy to determine the low output voltage problem. If you did not measure the output voltages of the power supply you may have thought it was a no power symptom. Furthermore, a low voltage output problem could cause the power LED not to light up. The procedure of voltage testing can be found in chapter 11- place the red probe to one of the cathode in the secondary side and the black probe to the equipment ground and power “On”.



**Figure 9.3- The Right Way To Place Your Test Probes**

If the voltage measured is lowered than the specification, then it is confirmed that it has low output voltage problem. You may ask **whether the output voltages are within specification or not?”**

Let's take this for example. If you are a seasoned Monitor repairer you would have know that the voltage supplied to the CRT heater/filament would be 6.3 Volt. If you measure the output voltage to the heater circuit and you got only 2 to 3 volts, this clearly indicated that the line have problem.

In other words, if you have 4 output lines and all of the output voltages dropped to half, then this proved that the problem is due to the low output voltage problem. If only one of the output lines has problem while the others are okay, then this shows along the faulty output line there must be some components that are faulty that pulled down the output voltage. Most of the time, it was the bad filter capacitor along the line that causes the voltage to drop.

Once you have identified that it was the low output voltage problem in the SMPS, then you can use the isolation method in chapter 14 to find out whether is the SMPS itself is faulty or the secondary side components problem that had caused the SMPS to produce low output.

### 3. **High output voltage**

Instead of producing the correct output voltages at the secondary side, all of the output voltages have increased in value. This is very common in ATX power supply where the 12 volts output may increase to 14 volts; the 5 volts output increase to 6 volts and so on. If the high output voltage problem happens in the Monitor or TV circuit, the SMPS will go into shutdown mode. You can test the output voltage with your meter to confirm the reading. Please refer also to power shutdown problem in page 121 as both of the high output voltage and power shutdown problems are quite similar.

### 4. **Power Cycling/Blinking/Chirping**

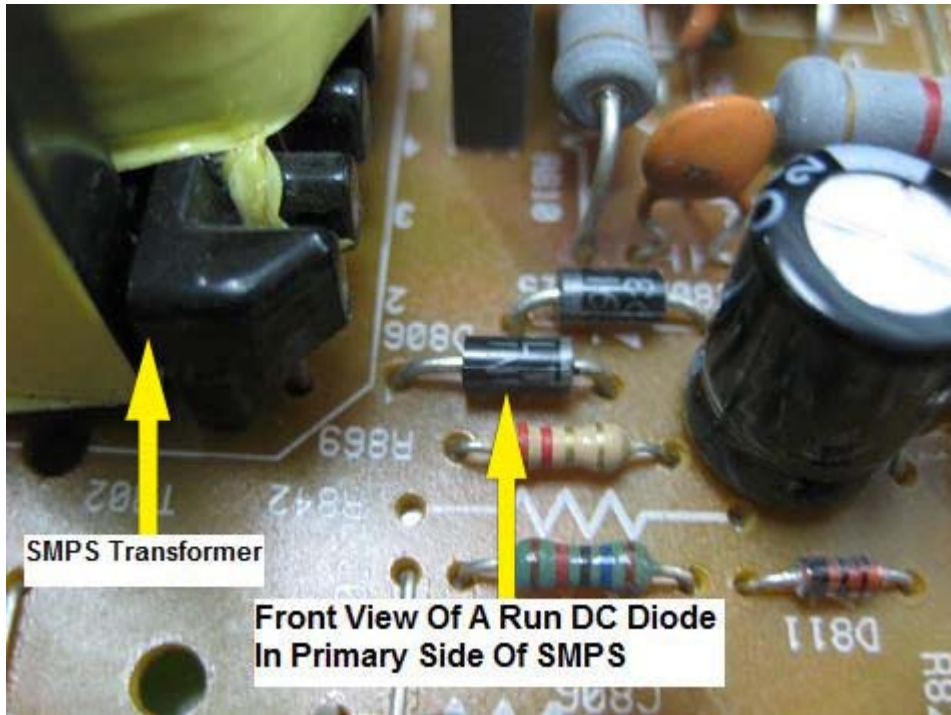
It is very easy to identify power cycling/blinking/chirping problem. Some technicians refer to it as **power pulsating problem**. Look at the power LED of the equipment and if it blinks, then it is a power blinking problem. If the SMPS does not have the LED power indicator (stand alone type of power supply), then you can place an analogue

meter red probe to the output diodes at the secondary section and black probe to cold ground (**voltage testing method**). The cycling problem will cause the meter's needle/pointer move up and down within the meter's scale. The SMPS tries to start up but because there are some components failures either at the primary or the secondary section, the power went down again and the cycle goes on.

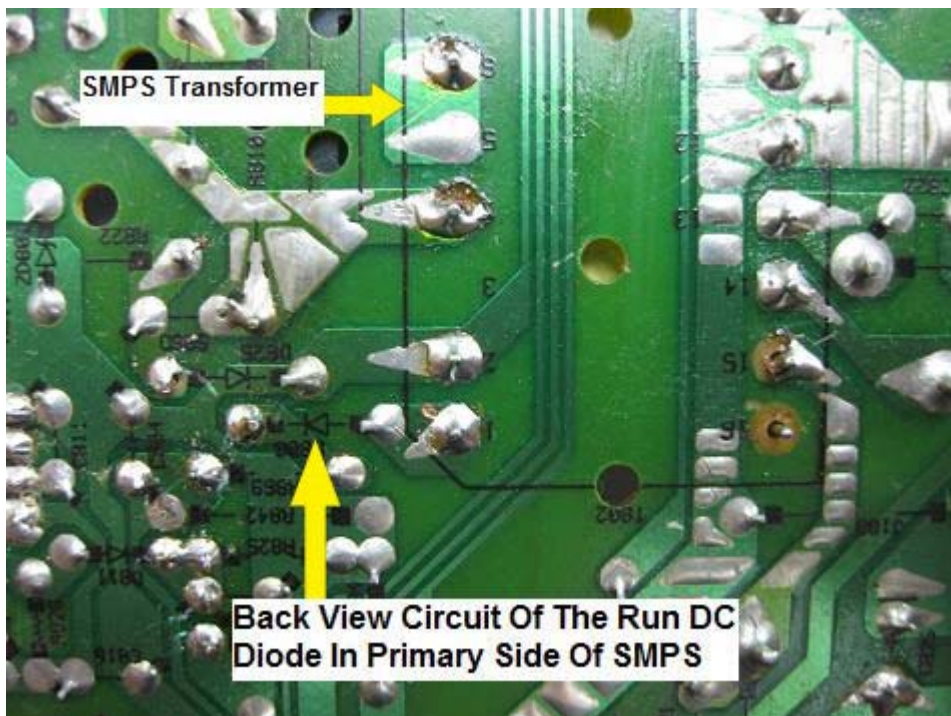
**Note: In some electronic equipment like the LCD TV's and LCD Monitors, LED blinks does not necessary have to be power problem. The blinking power LED signal that comes from the Micro Controller Unit (MCU) could indicate problem in the MCU IC itself or from bad circuits or corresponding components that causes the MCU to send an error signal through the power LED. The best way to confirm the power cycling problem is to use the voltage testing method.**

From experience, over 90% of power cycling problem was caused by bad components in the secondary section. It could be a shorted secondary diode, bad filter capacitors, and faulty components in the regulation circuits i.e. Sampling, Error Detection and Feedback Optoisolator IC (refer to page 38 and 39).

However I have come across the Run DC circuit diode breakdown when under load in the primary side causing the power supply to cycle. It took me many hours to locate such fault. So in the future, if all of the secondary side components are tested good, I guess your next step would be to directly replace the Run DC circuit diode and retest the power supply even though the diode tested good with your ohmmeter



**Figure 9.4- A Run DC Circuit Diode In Primary Side Of SMPS**



**Figure 9.5- The Location Of Run DC Circuit Diode In SMPS**



## 5. Power Shutdown

Normally, whenever a SMPS circuit has problem such as producing a too high voltage output the SMPS itself will shutdown. That means if you place your analogue meter red probe to one of the output diode and the output is a 15 volts line, you could see that the analogue meter needle will quickly kick up to more than 15 volts say 25 volts and then drop back to zero. This is called power shutdown problem. The reason for it to shutdown was to protect the SMPS from continuous producing high output voltage that can burn the equipment or other electronic circuitry. Please refer to page 40 under the topic of **“Protection Circuit”** to read how the SMPS can shutdown by itself.

## 6. Intermittent power problem

Intermittent power problem means that the SMPS sometimes can work and sometimes don't. It is quite frustrating too because when you want to test out the problem, the SMPS works perfectly okay and when you let the SMPS runs, it starts to break down after few minutes or hours later! In order to deal with this kind of problem, you need to use the **“handle of the screw driver”** to gently knock on the power supply casing or the board while the SMPS is running to see if there is any dry joints problem. If it stopped once you hit the board, then you can conclude that it has intermittent problem. Loose connection and dry joints contribute more than 90% intermittent fault in the SMPS.

**Sometimes an open start up resistor in the primary power side could cause similar problem too and you need to test the start up resistor with your meter. Refer to page 29 on the function of start up resistor.**

Now you have understood the six common problems in SMPS and I believe you should have no problem in identifying SMPS fault when a broken SMPS is sent in for repair!

## 10) How To Easily Discharge The Main Capacitor in SMPS



**Figure 10.1- Filter Capacitors In LCD Television SMPS**

The first thing you should do as an electronic repairer is to discharge the capacitor before touching the power supply section (after removal of the AC power cord). The large filter capacitor in the power supply section can hold dangerous high voltage even if the unit has been switched off for a few days. It is advisable to discharge the filter capacitor first before you start to troubleshoot in order to protect yourself from being electrocuted.

**Note: Many power supplies have the bleeder resistors across them to discharge the capacitor voltage after the Main power is Switched Off but others do NOT have. A High DC voltage from the filter capacitor makes your muscles contract and if you touch it, you might find yourself unable to let go. Thus it is necessary to take the proper precautions.**

Though the capacitor current stored in the capacitor can't kill you but it is enough to burn your hand, fingers and your skin when you accidentally touch it. The worst scenario is while you're carrying the Monitor or TV, you might just throw off the equipment when you received a shock from

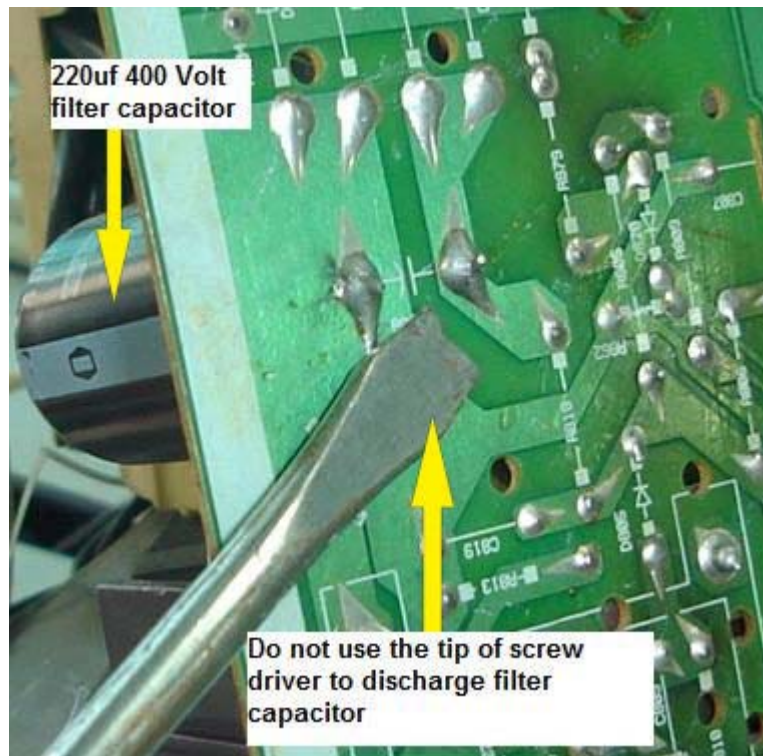
the filter capacitor. The cathode ray tube monitor may break and cause the flying glasses to hit your body or eyes.

Just be cautious when handling the power supply area. You can always use a meter to confirm whether there is still charged in the capacitor. Place your meter's black probe to the capacitor negative pin (you can see the negative marking at the sleeve of the capacitor) and the red probe to another pin. If there is a high voltage registered in your meter, then you have to discharge the capacitor. Otherwise you may proceed to repair the equipment. A typical value for this type of filter capacitor is 220 to 470 microfarad with a 200 to 450 voltage rating.



**Figure 10.2- A Large Filter Capacitor In CRT Monitor Power Supply Section**

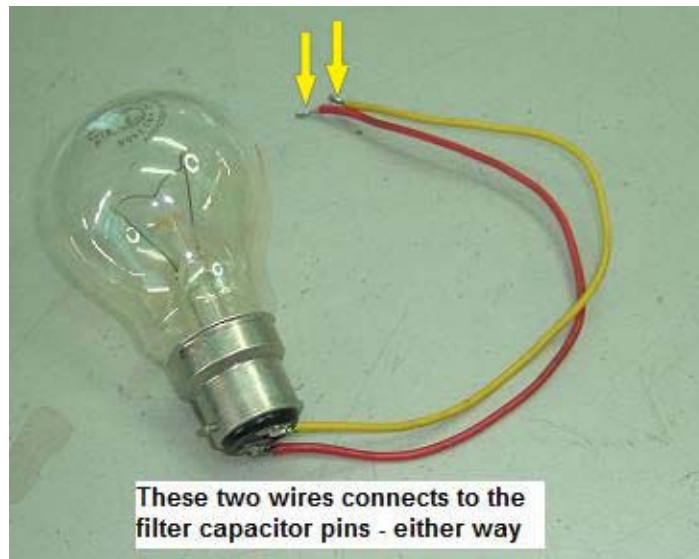
There are three ways to discharge the large filter capacitor in a switch mode power supplies.



**Figure 10.3- Please Do Not Use This Method To Discharge Filter Capacitor**

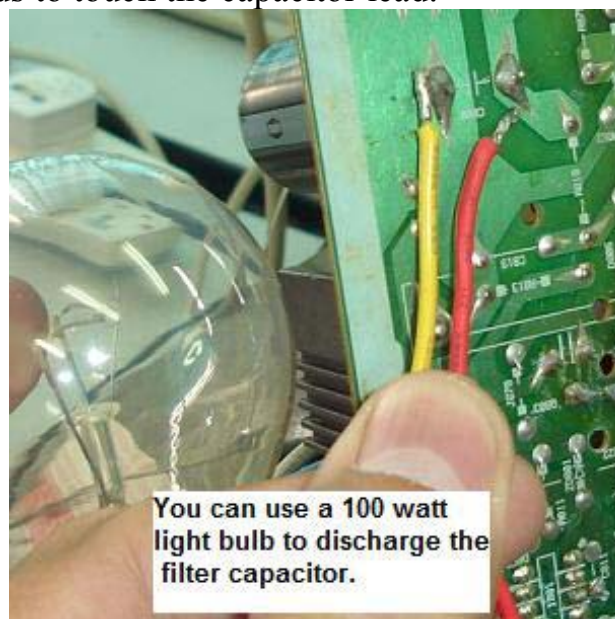
Discharging the capacitor with a screw driver is not recommended. The reason for not using the screw driver to discharge a capacitor is because the printed circuit board or circuitry can be damaged due to the spark generated while discharging the high voltage in the capacitor. I once had blown the power area using this method. However, if you know that the capacitor stored voltage is not too large after having confirmed it with a meter, you can easily discharge it with a small screw driver.

Just place the screw driver tip to touch the two pins of the capacitor and within seconds the charge will be gone. If the capacitor holds a heavier charge of electricity, then discharging the capacitor with a screw driver may melt the tip of the screw driver and the copper on the printed circuit board. Sometimes a big spark may cause small disintegrated solder lead or copper to fly out from the circuit board and might injured your eyes or body.

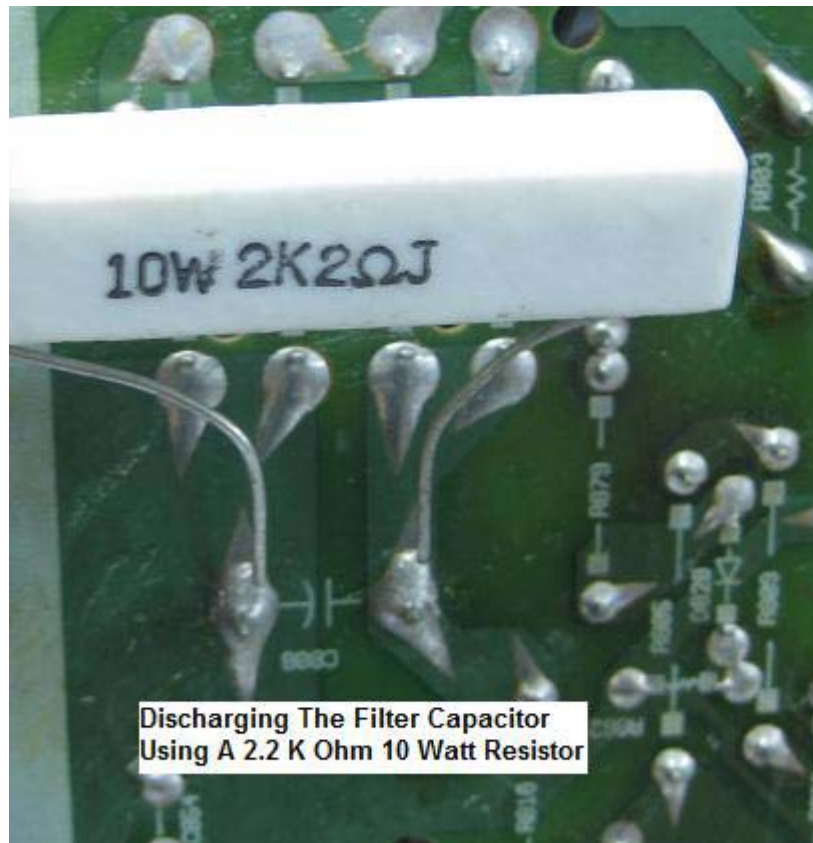


**Figure 10.4- A 100 Watt Bulb Is Used To Discharge Filter Capacitor**

Another method is that you can use a socketed 100 watt electric light bulb and touch the two wires coming out from the light bulb on the leads of the capacitor. This method had been used by many electronic repairers around the world for the light bulb will act as an indicator to see if the capacitor still holds the charge. If there is a charge, the light bulb will light and after discharging the light bulb will go off. In many cases, you would not be able to see the light due to the current being drained off too fast. I still prefer the third method because in the second method you have to use both hands to touch the capacitor lead.



**Figure 10.5- The Right Way To Discharge Capacitor With Light Bulb**



**Figure 10.6- Use A Resistor To Discharge The Capacitor Leads**

The third method and also my favourite method is to place the leads of a high wattage resistor on the leads (pins) of the capacitors you want to discharge. You can use either a **1.8 k or a 2.2 kilo ohm 5 to 10 watt** resistor to discharge the high voltage capacitor in a switch mode power supply. It is very simple to use and very effective too. It takes only a couple of seconds to fully discharge the capacitor. **Please do not hold the two ends of the resistor with your finger, only hold the body of the resistor.** Otherwise your fingers/hand may get discharge from the capacitor! Use only one hand to do the job while the other hand you can still hold on to the solder gun.

**Warning:** I highly recommend to those who are using the screw driver to discharge a capacitor in power supply to consider the second and third method as these are the safest methods. It not only protects the circuit but it also protects you. If you have discharged the capacitor and you are still not sure or have no confidence whether the charge is already gone, you can always use a meter to test and confirm it. Once the charge is gone, you are now free to touch on the power supply section and begin troubleshooting.

# **11) How to Easily Perform Voltage Testing On SMPS**

Checking the voltages in the SMPS is one of the best ways to repair SMPS problem. With just a simple voltage test on certain components or area in the SMPS, you can easily conclude whether the component or the circuit section is faulty or not. Do you know that there are many experienced electronic repairers performing voltage test in electronic equipment in order for them to solve a problem fast? They use the voltage testing method on all kinds of electronic circuit which includes the SMPS circuit. If you want to join them and be good in voltage testing, then grab this opportunity to learn from this topic as I will be guiding you step by step on how to easily perform voltage test in SMPS.

**Warning** - Before you begin the voltage test, make sure the AC Voltage from the Main is from an isolation transformer otherwise **quit this test**. I don't want you to get any severe electrical shock if you accidentally touch the hot side of the power supply and ground. If you have the AC voltage coming from an isolation transformer then let us begins with the test!

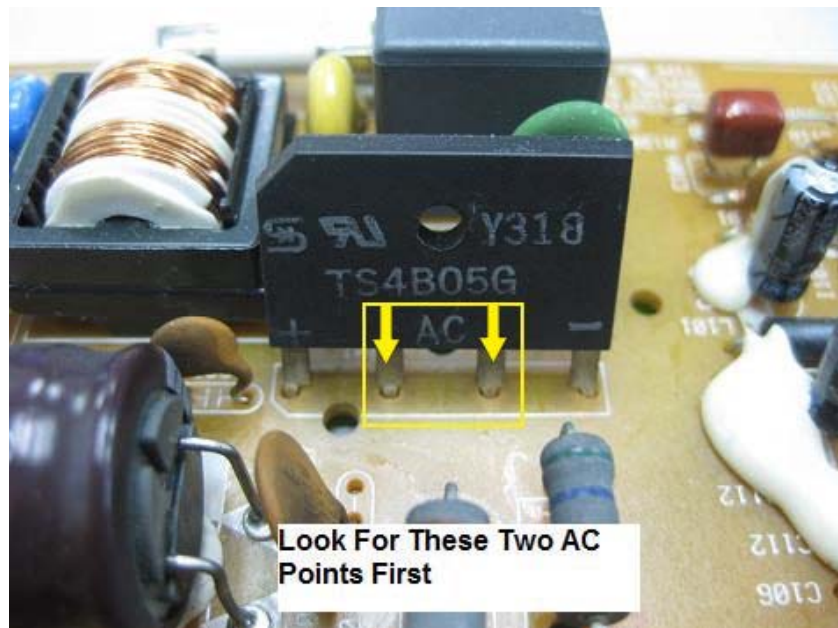
There are four points in SMPS where you can perform the test. The points are:

- 1) The AC input
- 2) The Filter Capacitor
- 3) The Supply Voltage of Power IC
- 4) The Secondary Output Voltages

These are the four critical test points that one should test in order to know where the SMPS problem is.

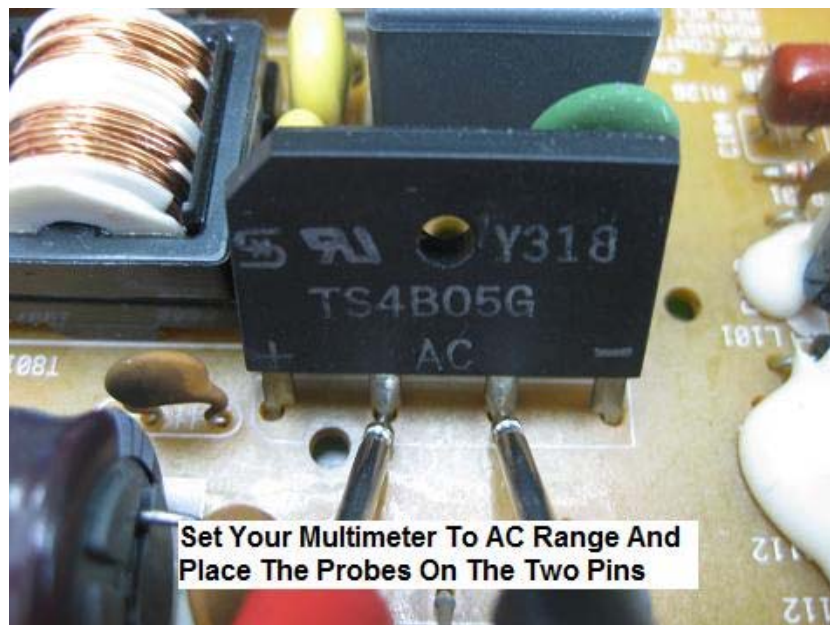
## **1 The AC Input Point**

The best point to test the AC supply input is at the two pins (two AC inputs) of the bridge rectifier. Testing this point will quickly let you know if the AC input is present or not. Do follow the pictures shown in the next page on how to perform the voltage test on bridge rectifier.



**Figure 11.1- Determine the Two AC Pins Of Bridge Rectifier**

Place the test probes either ways (AC voltage does not have polarity) to the two AC input pins of bridge rectifier. Hold the test probes tightly so that it won't slip away and touch on other pins. Otherwise it can blow the Main fuse and may create a loud "bang" that can scare you away.



**Figure 11.2- Place Your Test Probes To The Right Points**



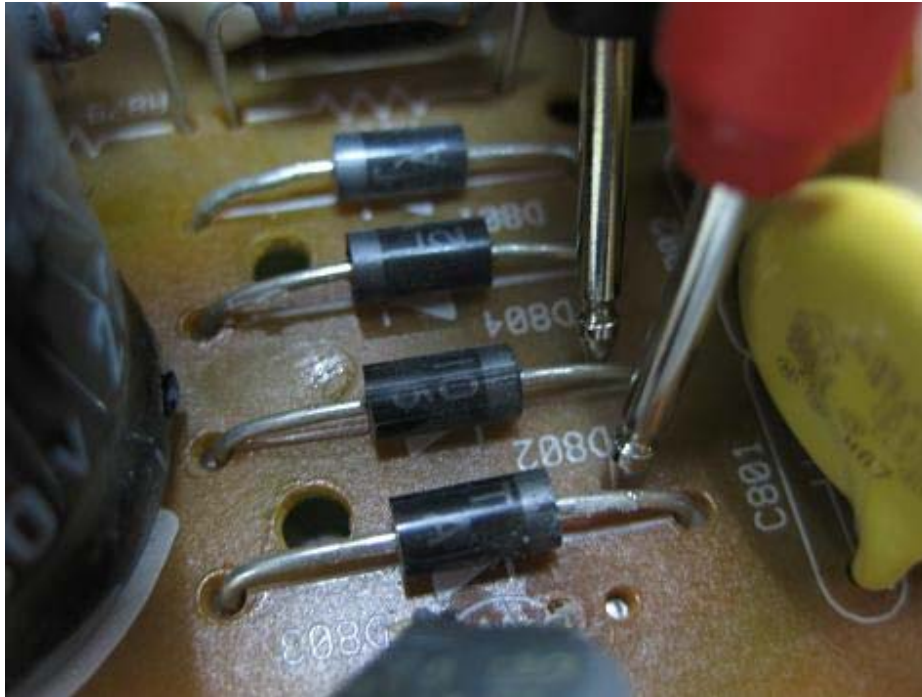


**Figure 11.3- The Test Result**

If you get a reading of about 230 Volts AC (in USA is 110 Volts) then this proved the AC voltage is good from the AC outlet. If you get zero voltage (or very less voltage) then you have to **check the circuit before the bridge rectifier**. Suspect these problems if there is no AC input to the bridge rectifier:

- a) The Main AC outlet Switch is not “On.”
- b) The On/Off switch of the SMPS is not “On” or have problem.
- c) The AC power cable has broken internally.
- d) Main fuse open circuit or loosen.
- e) Circuit track opens or have dry joints.
- f) The EMI coil may have open circuit.

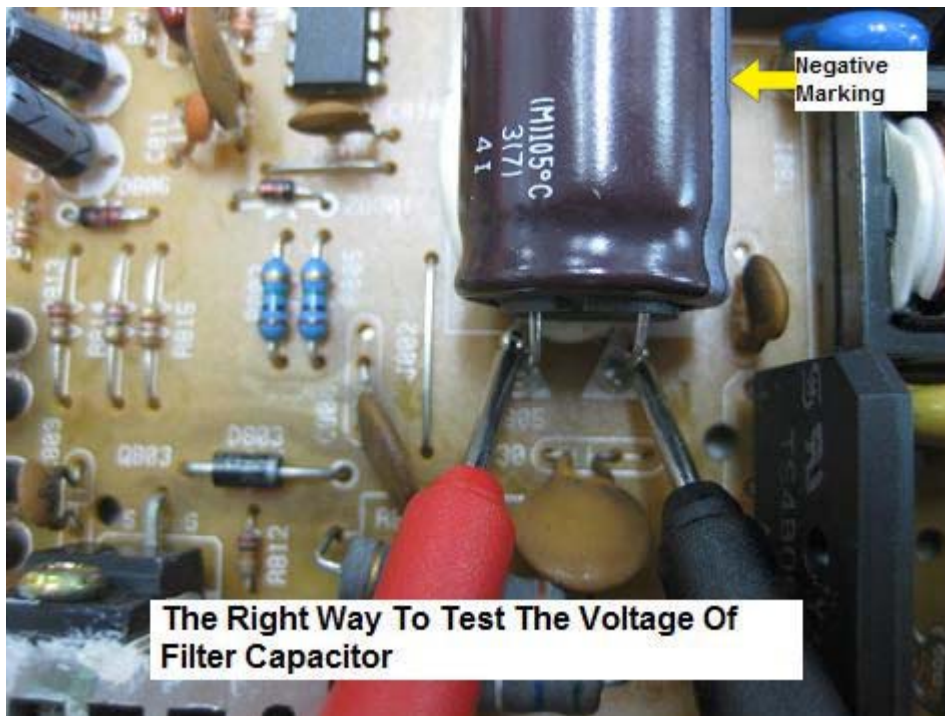
**Note: Not all SMPS have the same sizes of bridge rectifier and not all use a single package of bridge rectifier. If the designs have four individual diodes that form the bridge rectifier then place your test probes as seen in figure 11.4 in next page.**



**Figure 11.4- How To Place Test Probes On Bridge Rectifier That Have Four Individual Diodes**

## **2 The Filter Capacitor Point**

Once you have confirmed that the bridge rectifier has AC supply input, you should now expect about 300 Volts DC present (for USA about 150 Volts DC) at the positive pin of the filter capacitor. In order to test the voltage at the filter capacitor, **the black probe has to be at the negative pin side and the red probe to positive side** as shown in figure 11.5 in the next page.



**Figure 11.5- Testing Voltage At The Filter Capacitor Pins**

Remember to set your multimeter to DC volt range because the bridge rectifier has already converted the AC supply into DC output. If you get the expected DC voltage, then move on to perform another test which is the testing voltage at the input pin of the power IC which I'm going to explain to you in the next section.

If you get zero volts when measuring the filter capacitor then troubleshoot the area to locate if there is any problem with the circuit like dry joints, broken track and etc. If the DC voltage measured is lower than it should be, a high chance that the filter capacitor may have problem and you have to test it off board with a Blue ESR meter or a digital capacitance meter to check on the capacitance value.

**Note: Please discharge the big filter capacitor before you remove it and test it with the meters otherwise if the capacitor has charge in it, it will blow the meter!**

**Warning: Please make sure you hold tight to your test probes and carefully touch on the capacitor pins (meter's red test probe to positive pin and black probe to negative pin of filter capacitor). If you accidentally slip either one of the test probes and it touches on the other pin, a great spark would develop and blow the Main fuse**

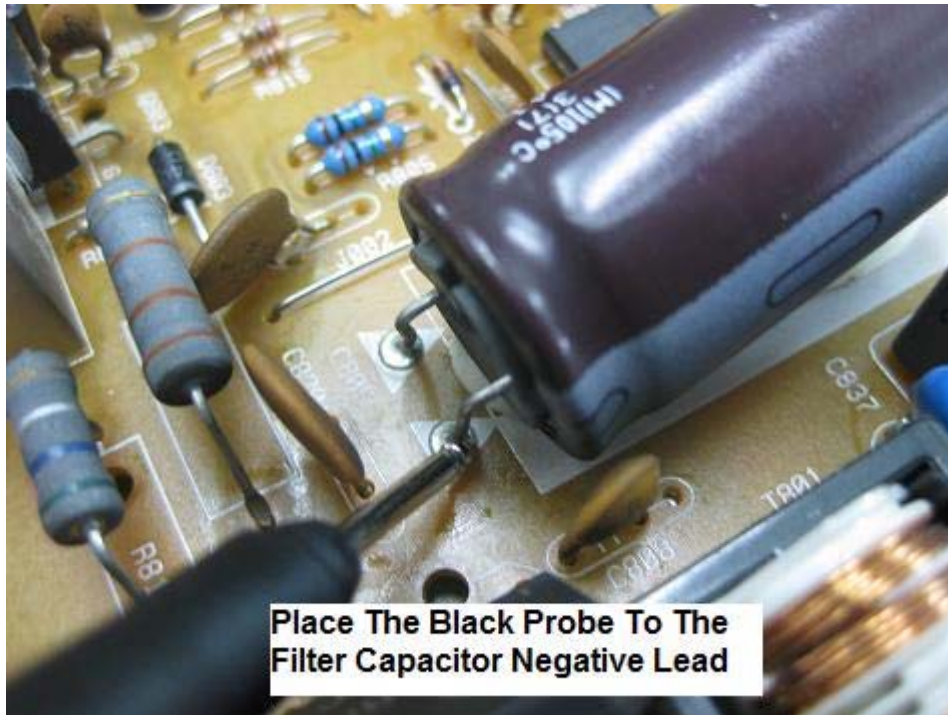
and sometimes destroy the primary section components too. Skip this test if you don't have the confidence to do it.

### **3 The Supply Voltage (VCC) of Power IC**

First, find the part number of the power IC from the schematic diagram, data book or from the Internet search and locate the VCC pin of the power IC. Once you have found the VCC pin, place the red probe of the meter to the VCC pin (remember to set your meter to DC volt range) and the black probe to HOT ground (primary filter capacitor negative pin) as seen in figure 11.7 and switch "On" the power. You should get a DC volt reading and the voltage depends on the SMPS designs. In figure 11.6, the DC voltage that I got was 16 Volts.



**Figure 11.6- Testing Supply Voltage At The Power IC Pin**



**Figure 11.7- The Right Way To Place The Black Probe**

Checking the supply voltage of the power IC could reveal many things in power supply. Here are three possible results that you can expect from the supply voltage test:

- 1) If the voltage measured is according to the specification of the power IC, this means that the bridge rectifier, filter capacitor and the start up resistors are working. You should now perform the next test which is the secondary output test (refer to page 144). Don't waste unnecessary time changing the bridge rectifier, filter capacitor or even checking the resistance value of start up resistor.
- 2) If you get zero volts and the filter capacitor has the full voltage, then suspect either the start up resistor has open circuit or the power IC shorted that pulled down the supply voltage.
- 3) If you get half of the required voltage (if the filter capacitor has the full voltage), then suspect the start up resistor has gone high in Ohm value, leaky power IC and bad corresponding components at the power IC like capacitors, diode, transistors and zener diode.

**Note: If the power IC has pins that are too close with each other (like SMD power IC legs) then I suggest that you place your red probe along the supply voltage soldering pad and not on the supply voltage**

**pin (VCC pin). This is because the red probe would not accidentally touch on the other pins and blow the power supply. I have blown few of them before so I don't want you to make the same mistakes as I did.**

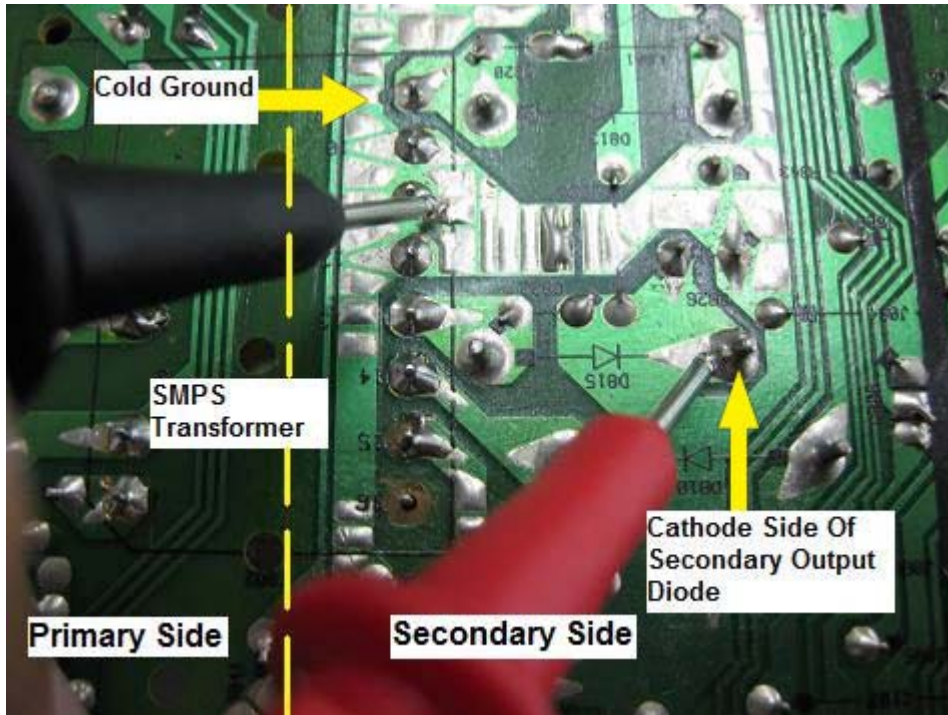
#### **4) The Secondary Output Voltages**

Among all the tests, this is considered the safest as this test is located in the secondary side and not in the primary side (hot side). Therefore there is no chance for you to accidentally touch on the hot side section.

However, be extra careful too even though you knew that the secondary side is not as dangerous as compare to the primary side. Some SMPS have two outputs while some have more than 5 outputs. Generally the testing method is the same regardless of how many outputs the SMPS has.

Before you start checking on the output voltages you should know what the expected output voltages are, so that you can compare the result of the testing with what you are expecting. That means if the expected voltage is 12 Volt and you get only 3 Volts then suspect that the SMPS have problem.

Let's begin to test! Place the red probe at one of the secondary output diode cathode side and the black probe to cold ground (the chassis ground) and power "On". You should get a **positive DC voltage** reading from the test and also from all the other secondary output diodes if the test probes touches on the cathode of other secondary output diodes. You can measure it from behind the board or from directly on top of the secondary output diode as seen from the photos in the next page.

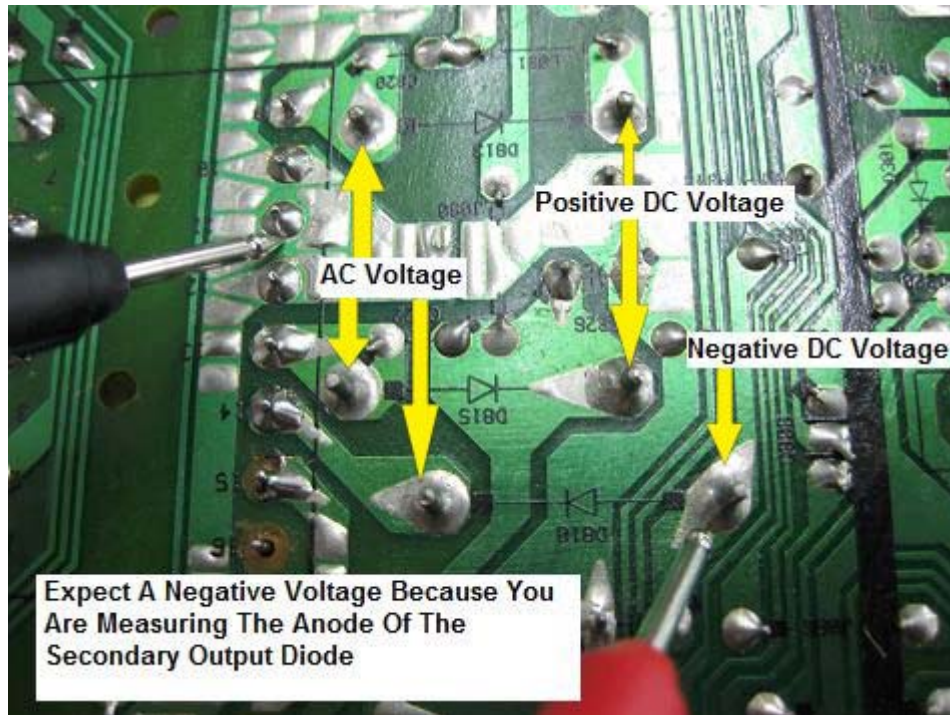


**Figure 11.8- The Right Way To Measure DC Voltage At The Secondary Side Of SMPS**



**Figure 11.9- The Right Way To Place The Red Probe To Check Positive Output Voltage Of SMPS**

**Note:** If the output diode is connected the other way round, then place your red test probe on the anode side and the black probe still in the cold ground and **expect a negative voltage** as seen in figure 11.10. **Please do not place your red probe at the cathode side of the diode under test because the cathode side now is on high pulse AC voltage produced by the SMPS transformer.**

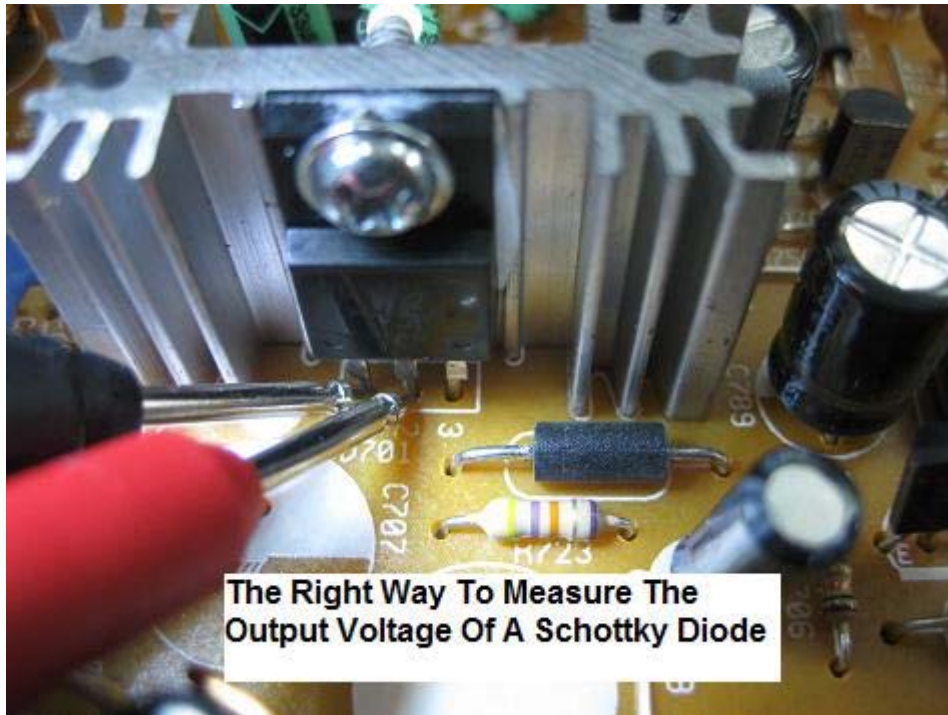


**Figure 11.10- The Right Way To Measure The Negative Voltage Of Secondary Output**

For your information some electronic circuits need negative voltage to function like the vertical IC in vertical section of a CRT Monitor and the Computer Motherboard (needs negative 12 volt).

Nowadays, many SMPS used dual Schottky diodes as seen in figure 11.1 as secondary output diode. The test method is quite the same. Simply place the red test probe to the centre pin (where the two Schottky diodes symbol face each other) and the black probe to cold ground and measure the output voltage.

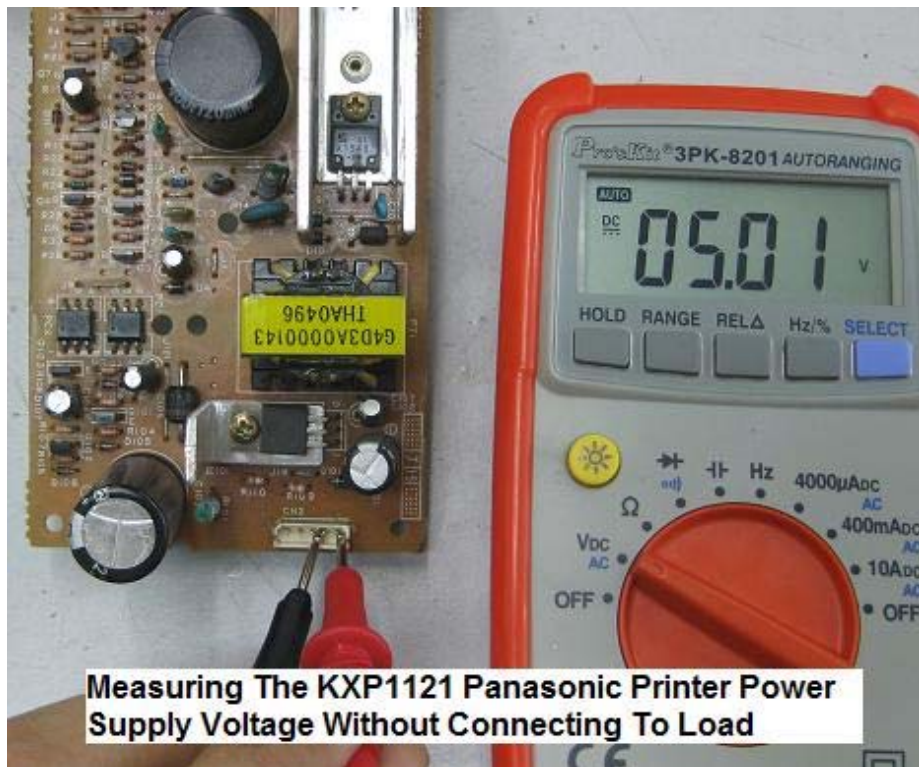




**Figure 11.11- The Right Way To Measure The Output Voltage Of A Schottky Diode**

**Note: When testing a SMPS makes sure there is a load.** If you are measuring output voltages of SMPS in equipment like TV, Monitor and etc then this means the output of the SMPS is already connected to loads (like the color circuit, high voltage circuit, vertical circuit and etc) and you need not worry of connecting another load to it. However for some SMPS like the computer PC SMPS and the **Stand Alone type SMPS**, you need a load to test the output voltages otherwise the SMPS may go into shutdown mode.

For your information, I had came across some dot matrix printer supply that **does not need a load** (motherboard) in order to function. You can straight away plug in the AC supply and expect voltages to be present at the output. If you are not sure whether one needs to connect a load when measuring the output voltages of SMPS, you just connect it to remove the guessing game. Once you have repaired many SMPS, you will know from your experience whether a SMPS should need a load or not.



**Figure 11.12- Testing A Power Supply Output Voltage Without Connecting To Load**

There are six conditions that could occur when you test the output voltages of the SMPS.

- 1) **Correct output voltages-** This means the SMPS is good and you should concentrate to locate faults in other areas like in the Main board or the load. If you continue to spend your time finding bad components in the SMPS even though you have already got the correct output voltages, you will be **wasting your time**. That's why there is a good advantage of performing the voltage testing to confirm which section is faulty i.e. the SMPS or the load.
- 2) **Zero Output Voltages-** This clearly indicates that the SMPS is faulty or something in the load has a severe short circuit that prevents the SMPS from starting. Please refer to chapter 14 "**The Five Methods That I Use To Troubleshoot and Repair SMPS**" on how to solve this problem.
- 3) **Low output voltages-** Bad components in either primary or secondary side could cause such problem. From experience, the current sense resistor that had change in resistance value and high ESR value in secondary filter capacitor could also contribute to

such problem. Do not overlook that the load problem can also pull down the output voltages. Please refer to chapter 14 **“The Five Methods That I Use To Troubleshoot and Repair SMPS”** on how to solve this problem.

- 4) **Higher output voltages-** All of the output voltages are slightly higher and if it too high it would cause the SMPS to shutdown. This problem could be caused by an open resistor or resistor that had turned into high Ohm in the feedback area. Check the Optoisolator IC and the corresponding components as well. If only one of the output lines has increased in voltage, suspect a bad inductor in the output line or dry joints in the load area of that line.
- 5) **Output Power Cycling-** The readout from the meter scale (assuming you are using an analogue meter to test the output voltage) shows that the pointer/needle moving up and down and up again and then down, this process is continuous. This could be the cause in primary, secondary, feedback circuit (Optoisolator circuit) and also in the load (slight leakage in the load components). Please refer to chapter 14 **“The Five Methods That I Use To Troubleshoot and Repair SMPS”** on how to solve this problem.
- 6) **Output Power Shutdown-** The readout from the meter scale (assuming you are using an analogue meter to test the output voltage) shows that the pointer/needle kicks up and then drops back again. When you switched off the power supply and switched “On”, the same situation happens again. This is most probably due to the problem in the primary, secondary, feedback circuit (Optoisolator circuit) and also in the load too. Please refer to chapter 14 **“The Five Methods That I Use To Troubleshoot and Repair SMPS”** on how to solve this problem.

**Carefully go through this chapter again as the voltage testing method is one of the fastest way to locate fault in SMPS and in any other electronic equipment circuit.**

## **12) How To Use Oscilloscope To Test SMPS Waveforms**

Multimeters have a disadvantage which is they can't be used to check a waveform or signal. Normally, technicians use an oscilloscope to check for the right waveform (input or output waveforms) in a particular IC or circuit to determine if the IC or the particular section is working or not. He could quickly summarize if the SMPS is faulty or not just by placing the scope probe onto certain test points in SMPS.

For your information, I don't always use oscilloscope to check for waveform in every repair. It depends on the complaint of the SMPS. If there is no output voltages at the secondary side (and the Main fuse and power components didn't blow in the primary side) or the output voltages fluctuate, I may need to use the oscilloscope to see if the right waveforms is present or not in a particular test point. Otherwise I will just use the method in chapter 14 **“The Five Methods That I Use To Troubleshoot And Repair SMPS”** to find out the fault.

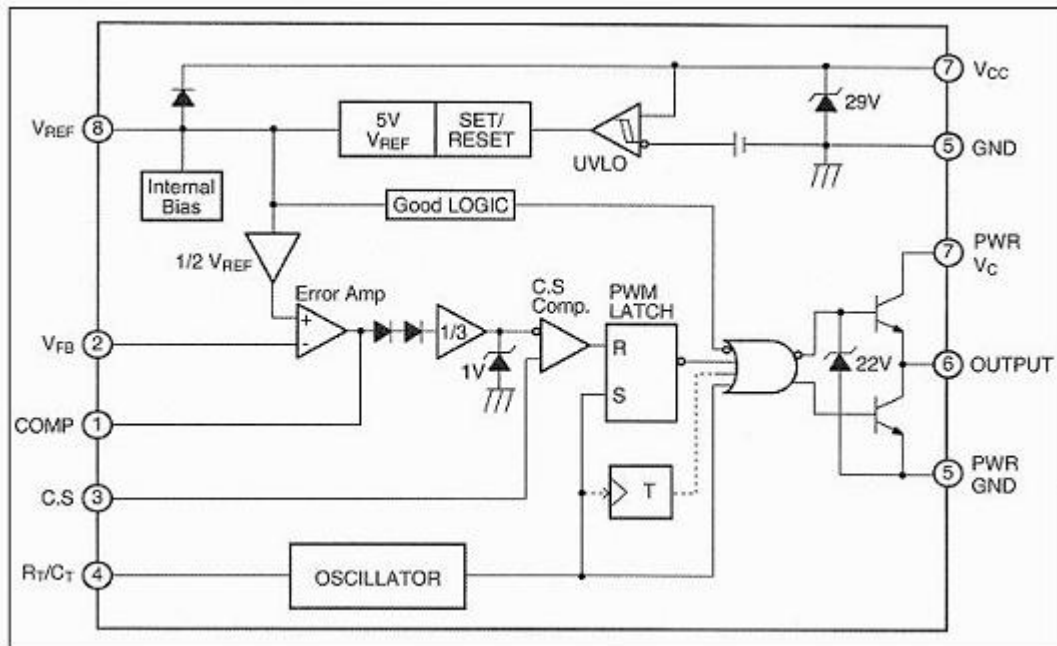
There are actually two critical test points in any SMPS. The first would be the output waveform from Power IC and the second one would be the DC output waveform from all the secondary output diodes. Let's start with the first one.

### **1 Waveform Test Point at Output Pin of Power IC**

First, read the part number printed on the Power IC and then search for its data sheet from data book, schematic diagram or from the Internet. Searching from the Internet would give you the latest information on many IC data. Let say the part number is UC3842, go to Google dot com and key in one of these keywords as shown below to look up for the data:

UC3842 datasheet (or data sheet)  
UC3842 pdf (or pdf files)  
UC3842 diagram  
UC3842 marking  
UC3842 code  
UC3842 coding  
UC3842 circuit  
UC3842 spec (or specification)

Try using these keywords provided to apply on any IC or semiconductor part number that you want to search from the Internet in the future. Once you found the datasheet of the Power IC, look for the diagram to see which pin is the output. Then you can place the oscilloscope probe at the pin and see the output waveform (This test requires you to “On” the equipment). In the example given below, pin 6 is the output because it goes to the gate pin of power FET.



**Figure 12.1- The UC3842 PWM IC Pinout**



**Figure 12.2- The Right Way To Place Scope Probe On Power IC Pin**

**Warning:** Just before you begin to place the scope probe to the testing point, make sure the AC supply is from the isolation transformer. Otherwise by connecting the scope ground to the hot ground (negative side of big filter capacitor) it could cause the ELCB of your workplace/house/building to **trip!**

The oscilloscope ground (black colour probe of the oscilloscope) has to be connected to the primary power supply ground (HOT ground). The best location is to clip the probe at the negative pin of filter capacitor as shown in figure 12.3 in the next page.



**Figure 12.3- Connecting The Oscilloscope Ground Lead To The Negative Side Of Filter Capacitor In Primary Side**

**Note:** If you want to check the secondary side then clip the probe at the cold ground.

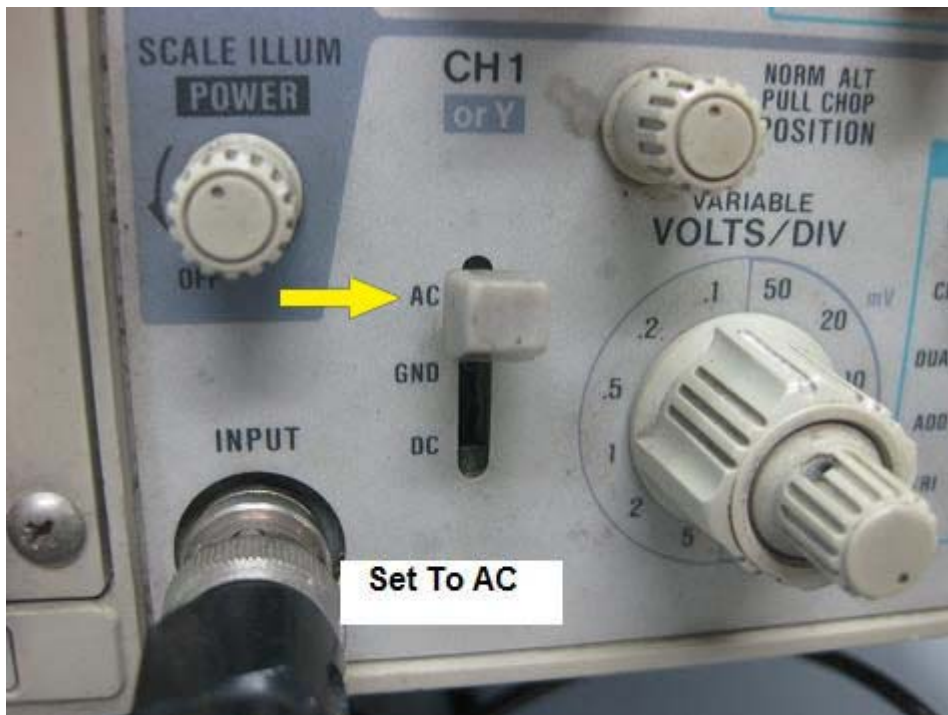


**Figure 12.4- Connect The Scope Ground To Cold Ground If You Want To Check The Secondary Side**



**Figure 12.5- A Typical Analog Scope**

Set your scope setting to AC and adjust the voltage per division and the time base setting as seen from the photo until you get the waveform.



**Figure 12.6- Set To AC Range**



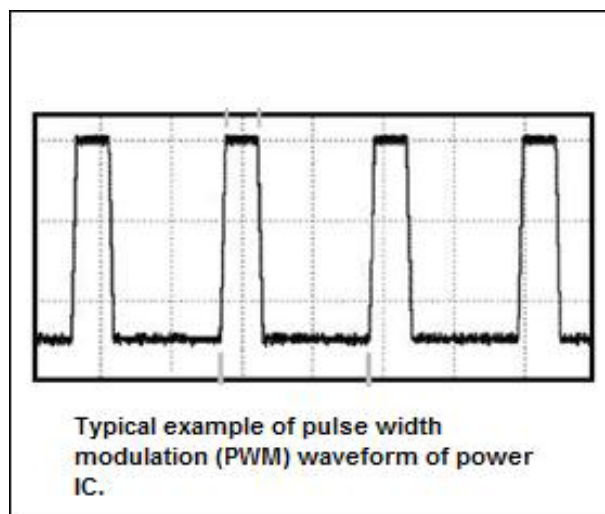
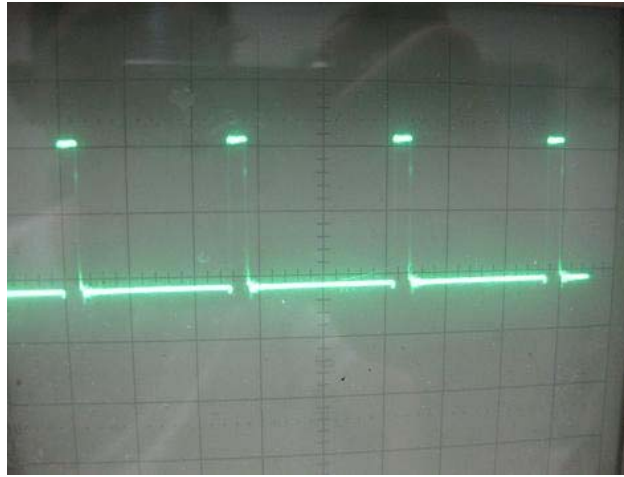


**Figure 12.7- Set The Time Per Division**



**Figure 12.8- Set The Right Voltage**

The example of waveform you will get when measuring the output of power IC is shown in figure 12.9. **Of course some power supply designs may have a slightly different waveform but it has to be a pulse square wave.**



**Figure 12.9- Typical Example Of Pulse Width Modulation Waveform Of Power IC**

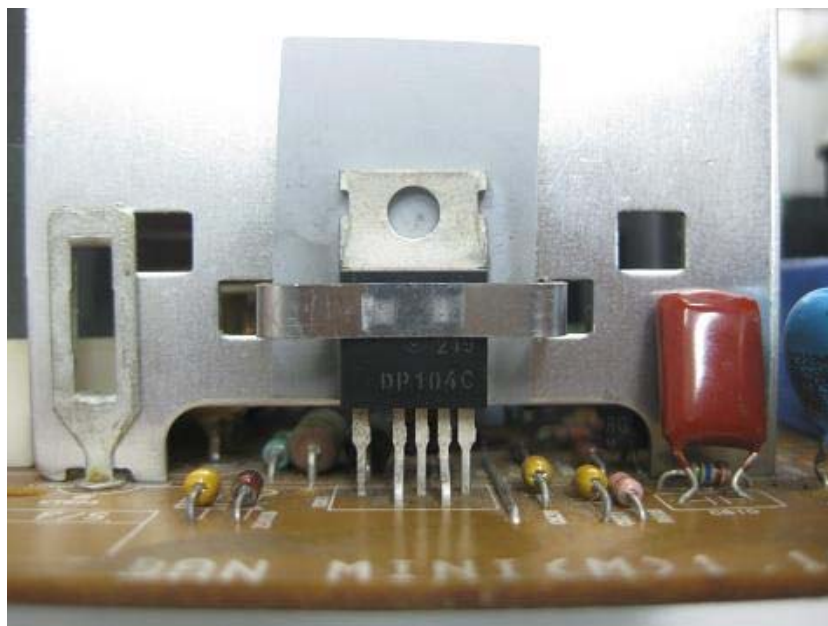
Note: **Hot ground and Cold ground is different!**

**There is one question- why should we measure this output waveform of power IC and not other waveform in the primary side of the SMPS?**

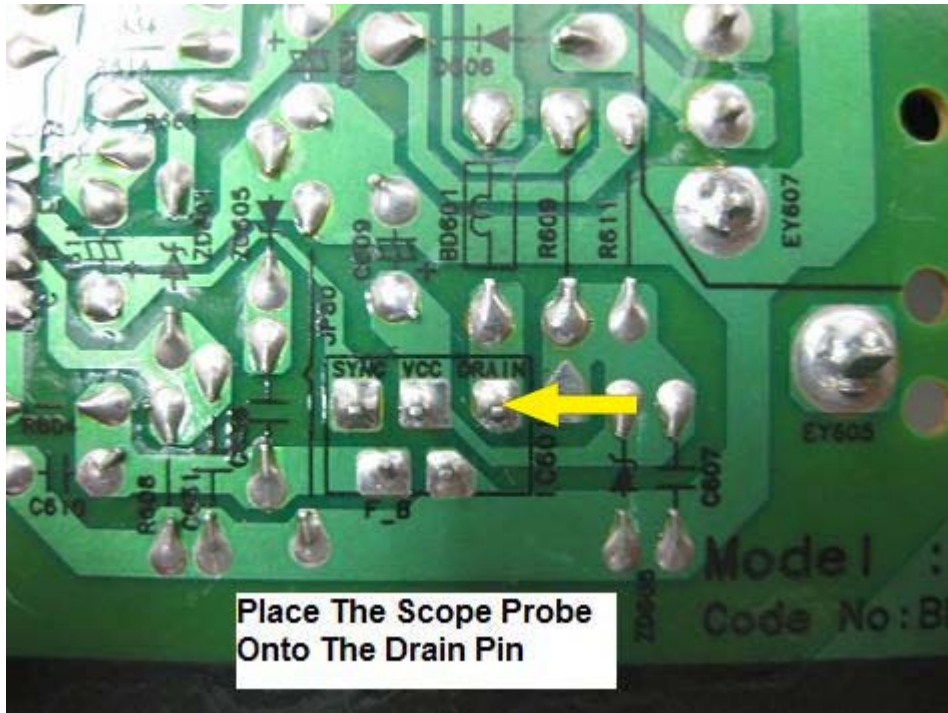
It is because the output waveform test result could tell us if the SMPS is fully working or not. This means if you got a good output waveform, it indicates that the Power IC is receiving the correct supply voltage and also the corresponding components are working fine. Your next step would be to locate faults in some other areas like in the secondary section. Sometimes dry joints or track broken between the output pin of the power IC to the gate pin of power FET could cause the power FET to stop switching and the result will be no power.

If there is **no waveform or improper waveform output** but with good supply input (VCC), then it could be caused by many factors. It might be a defective power IC itself, shorted power FET (or power transistor) that dragged down the output waveform, dry joints, faulty corresponding components, shorted primary winding in the power transformer, shorted components in secondary side that shutdown the power IC through feedback circuit and etc.

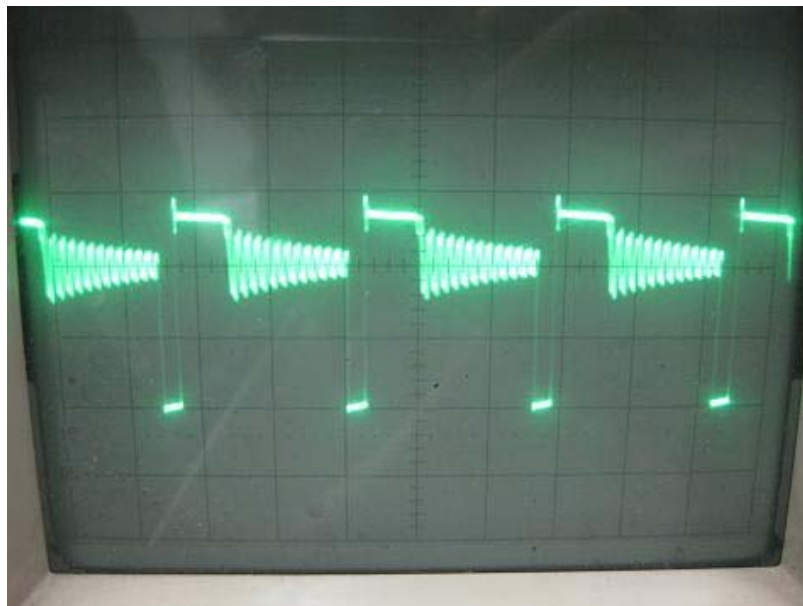
**Note: In many modern SMPS, the power FET is integrated into the power IC as seen in the photo below. What you should do now is to place the scope probe onto the drain pin of the power IC as seen in figure 12.10 and the expected waveform is at figure 12.12**



**Figure 12.10- Power IC With Built In Power FET**

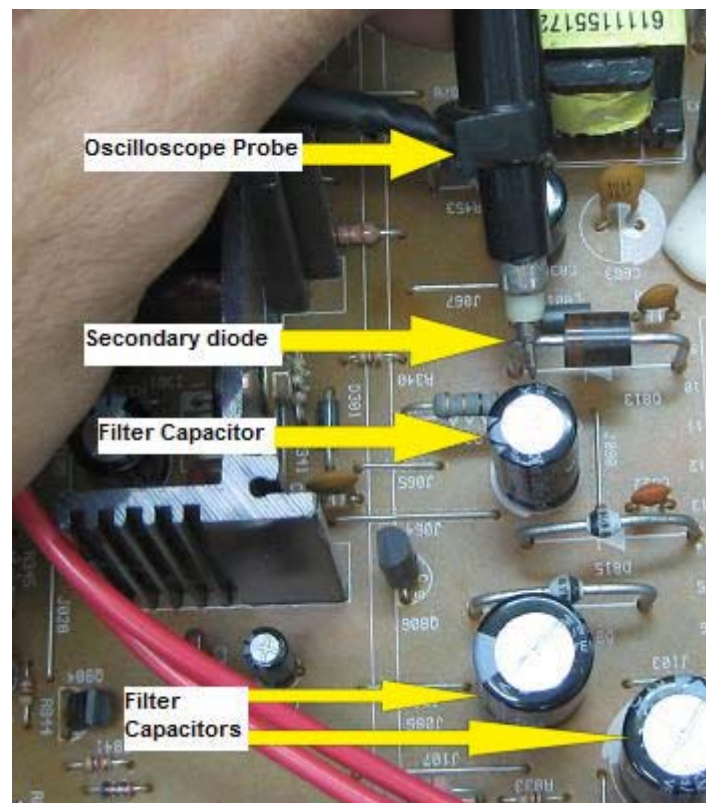


**Figure 12.11- The Right Way To Test The Power IC Drain Pin Waveform With Scope**

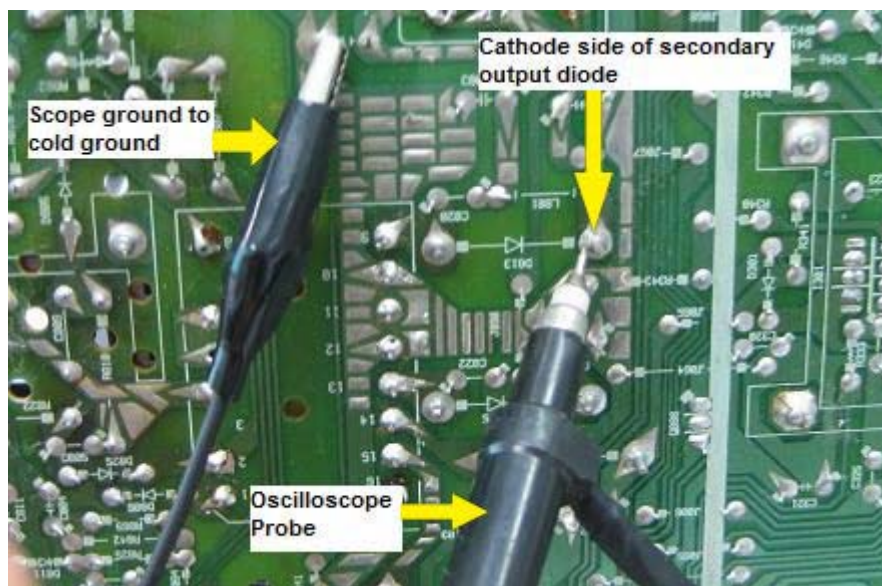


**Figure 12.12 –A Typical Waveform Found In The Drain Pin Of Power IC or Power FET**

## 2 Secondary Output Waveforms Test Point



**Figure 12.13- The Right Way To Place The Scope Probe On Secondary Output Diode**



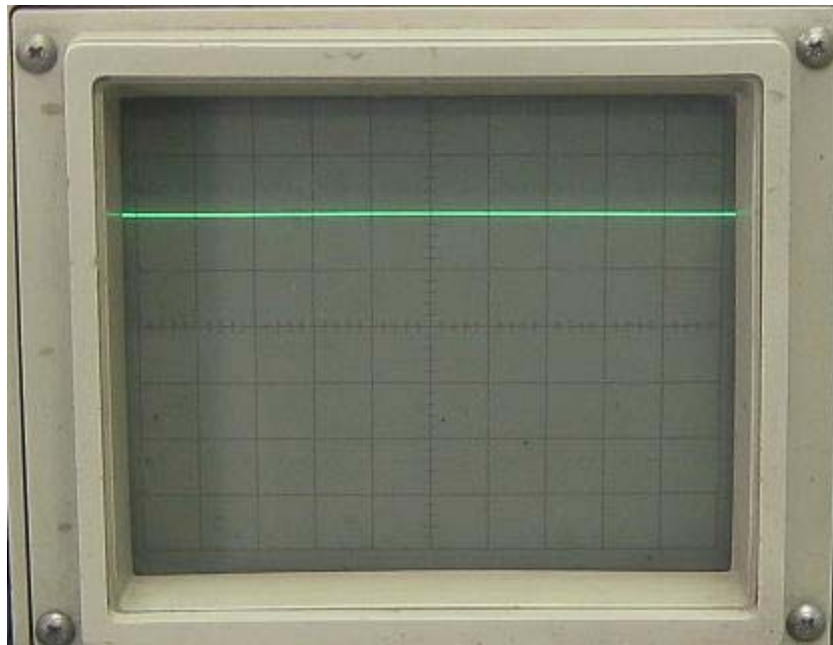
**Figure 12.14- You Can Place The Scope Probe Behind The Board**

All good SMPS should produce output voltages that have clean DC. What does this clean DC mean? Just place your scope probe onto one of the

output diode (cathode side) and the black probe to cold ground and see the waveform-of course you have to test it with the power switched “On” and set the oscilloscope to DC setting.

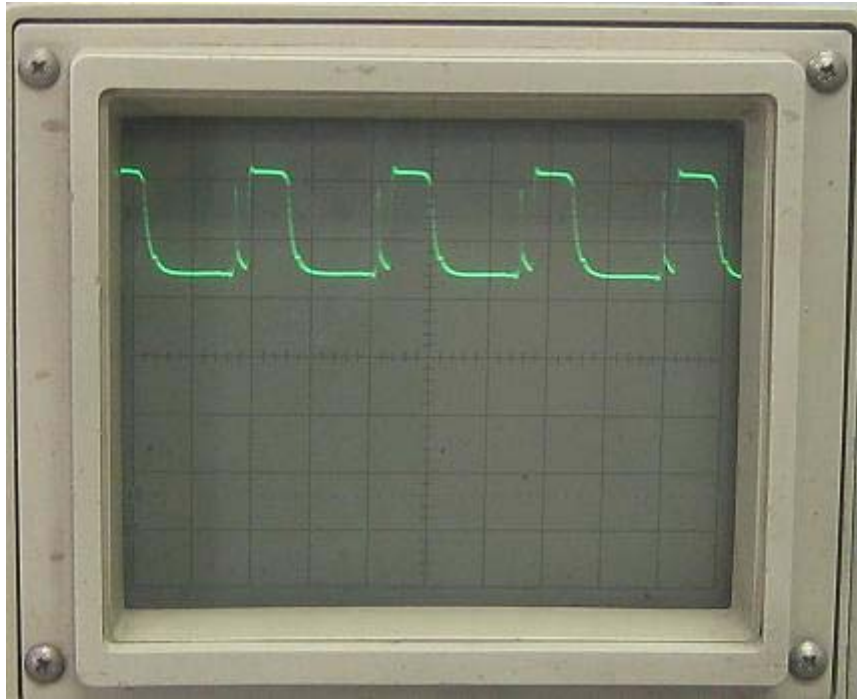
The waveform should have one horizontal line without any distortion or ripple. This indicates a clean DC output as seen in the below photo. Just before you perform this test, make sure the scope **setting is set to DC** and not AC otherwise you would not get the result as you would expect. Select the voltage per division to get the desire output waveform.

Once you got this kind of clean DC waveform you will immediately know that the primary filter capacitor and the secondary filter capacitors are working fine.



**Figure 12.15- A Good DC Output Waveform Of SMPS**

If you get this type of waveform as seen from figure 12.16, you will know that the ripple is present and you need to check on the filter capacitors with the Blue ESR meter.



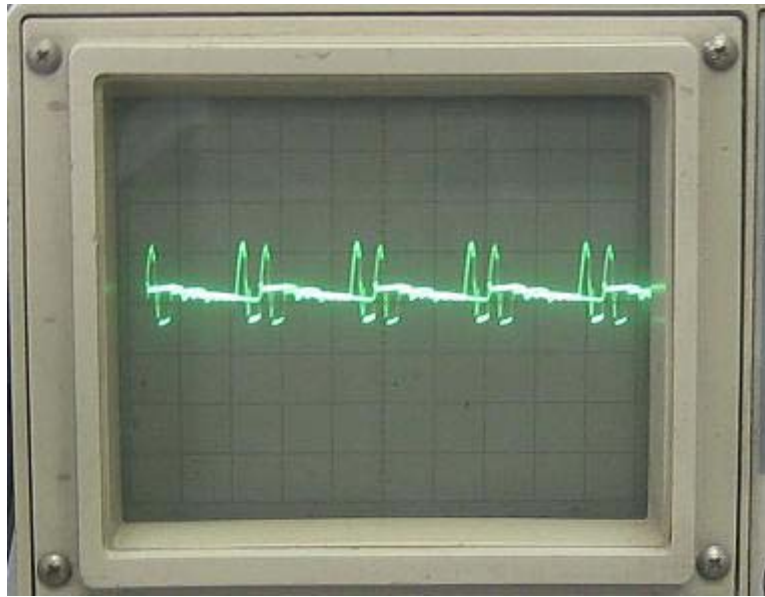
**Figure 12.16- A Typical Example Of Ripple Waveform**

### **Frequency Test**



**Figure 12.17- Placing The Scope Probe On Switch Mode Transformer**

By placing the scope probe on top of the SMPS transformer you could see a waveform at your oscilloscope.



**Figure 12.18- A Typical Example Of Waveform Taken From A Working CRT Monitor**

The scope could pick up the frequency and this shows that the transformer is working. If the SMPS section is not working due to faults in power IC, bad components, faulty SMPS or etc your oscilloscope will only show a one horizontal line.

**Note: Different SMPS may produce different types of waveform and the above waveform is just for reference purposes.**

You could also place the probe of a Multimeter that has the frequency range on top of the power transformer to test the frequency and to see if the SMPS is working or not. Please refer to figure 12.19 in the next page.





**Figure 12.19- The Right Way To Place Your Test Probe On The SMPS Transformer**

If you haven't invest in an oscilloscope, I strongly suggest you to get one as with an oscilloscope it can cut short your troubleshooting and repair time and no more guessing game. You will surely know if a particular IC or electronic circuit is working or not with the help of an oscilloscope. If you are on a tight budget, you can always buy a used analogue oscilloscope from Ebay dot com. This is much cheaper than buying a new one. If you have the budget you may get a more sophisticated one like the digital oscilloscope. The oscilloscope that I'm using in my repair workshop has already paid itself back many times the investment. With all these waveforms test given I believe troubleshooting SMPS would be much easier and faster for you.

## **13) Find Out How Useful Is The Series Light Bulb Trick In SMPS Repair**

I still could recall during my early days working as a technician in a computer firm fixing lots of computer power supply. Whenever I test a SMPS (after repaired), I have to stay quite far away with my ear closed before I switched “On” the power supply. The reason for it was to avoid the loud “bang” from the power supply and to avoid any flying pieces of components just in case if I didn’t fix the power supply properly. Can you imagine after replacing the power semiconductors in the power supply I have to act that way every time before I switched “On” the power supply?

Not only that and if the power supply components blow again, I have to recheck the power circuit and replace the blown components and retest it. For your information all these testing and checking are a waste of time and money if the power supply components blow again. Are we going to recheck it until we found the cause of the problem? There must be a better way of dealing with this kind of problem. Now I don’t need to close my ears and stay far from the power supply anymore thanks to the series light bulb trick! **The series light bulb trick for testing repaired power supply had saved me thousands of dollars in parts because the new replacement parts would not blow even if there are still components shorted in the power supply!**

Question 1- What is the reason for using the series light bulb in the power circuit?

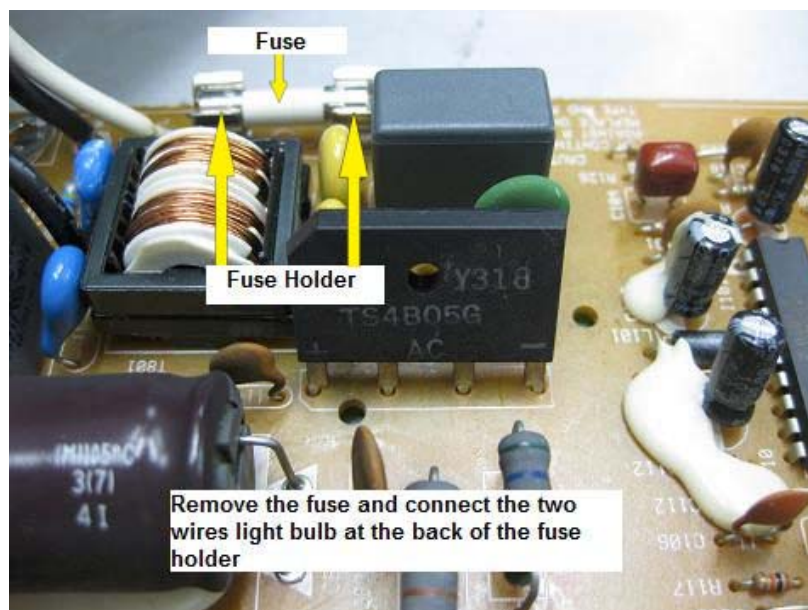
The reason is simple- to **limit the current** to power semiconductors in power supply such as bridge rectifier, power FET or transistor, power IC, and diodes (primary or secondary diodes) so that the components would not blow. Without it and if there's still a problem in the power supply, the semiconductors would surely get hot and blow again if there is short circuit somewhere in the SMPS.

Questions 2- What is the light bulb wattage used and how do I connect the light bulb in the circuit?



**Figure 13.1- A 100 Watt Bulb**

The wattage of the light bulb is generally 100 watt. If you want to troubleshoot a bigger set of equipment such as a big amplifier and projection TV you may use the light bulb from 150 to 200 watt. The connection has to be in series with the AC line. Assuming you have replaced the bad components in the SMPS, now connect the two wires across the two side of the fuse holder as shown in figure 13.2. You may solder the two wires of the light bulb behind the board as seen in figure 13.3.

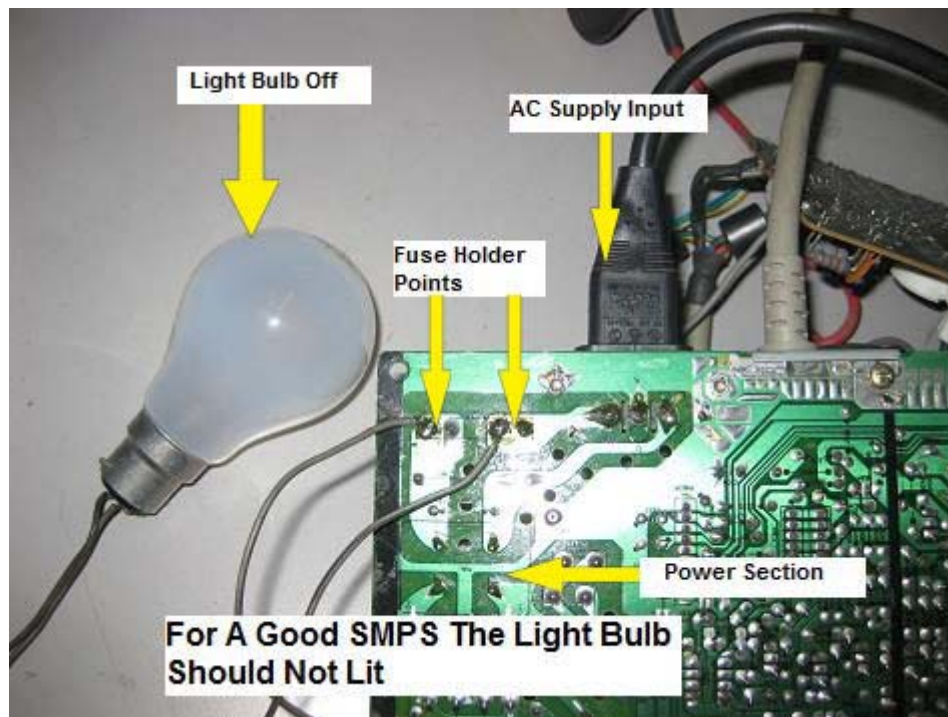


**Figure 13.2- First Remove The Fuse**

Question 3- What do I expect from the light bulb when I power up the SMPS or equipment?

There are three possibilities that can happen to the light bulb when you power “On” the repaired SMPS or equipment:

### 1. Light Bulb Off



**Figure 13.3- How To Connect A 100 Watt Light Bulb**

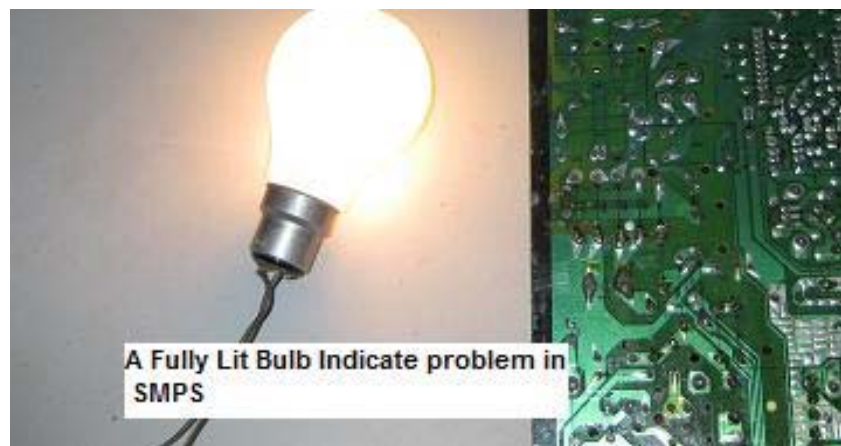
The light bulb will initially become bright but then settles at reduced brightness and eventually turns off. The reason for it was because at first it charges up the filter capacitor rapidly and then gradually slows causing the light bulb to go dim and turns off. This is the result (light bulb off) that we are expecting if the SMPS is working fine.

Please bear in mind that with the light bulb off, this doesn't mean that the power supply is 100% working but **at least it will not blow the power components again**. If it still does not function even with the light bulb is turn off, then it could be some other components in the power supply that you did not check. You may have to recheck the power supply again for bad components like an open resistor, bad capacitor and etc.

Note: Some electronic equipment like Monitors and Televisions can't operate even though the light bulb is **already off**. This is most probably

due to the Microcontroller IC (MCU) sensing the drop in the input voltage (or voltage not stable) to the MCU and thus shutting down the SMPS through Optoisolator circuit. Please refer to page 39 for more information about feedback circuit. In this case, the only choice you have is to place the fuse and power “On” the set and see the result. At least now you are **very sure** that the SMPS would not blow the fuse because in the earlier test, the light bulb was off.

## 2. Light Bulb Very Bright

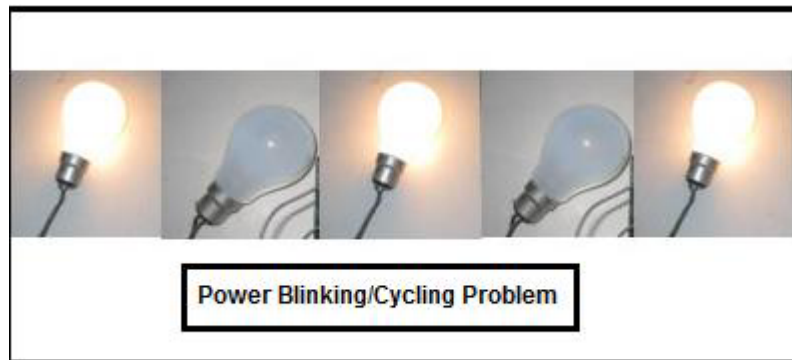


**Figure 13.4- Light Bulb Very Bright**

The light bulb is very bright even after you have waited for a couple of minutes. This indicates there is still problem with the SMPS and you need to switch off the AC main. Discharge the big filter capacitor and begin to troubleshoot until you have found the shorted component. It could be a shorted Bridge Rectifier, Power IC, Power FET and etc.

**Note: A shorted SMPS transformer primary winding could cause the light bulb to glow very bright and you need to use the Blue Ring Tester to test the primary winding.**

### 3. Light Bulb Pulsating/Blinking/Cycling (Slow or Fast)



**Figure 13.5- Showing How The Light Bulb Pulsate**

The light bulb could pulsate/blink very fast or in some cases it could pulsate very slowly. The power supply is actually trying to come up but is shutting down most probably due to the light bulb wattage which may be too small for the equipment (not enough current flowing to the SMPS).

Question- If the power supply blinks, can I put the fuse back and “On” the power supply?

Before you put in the fuse, there is one test that you should make. Place the red probe of your analogue meter to one of the secondary side diode (output diode) and the black probe to cold ground (**please refer to chapter 11 on how you can connect the test probes for voltage testing**). Now, power “On” the SMPS or equipment and assuming the light bulb is pulsating/blinking, and you get to see the meter’s pointer/needle kicking up and down (**this shows that the secondary side have output**). You can conclude that the power supply is actually working. The reason why the bulb pulsates is because the power supply is not getting enough of current. In this case you can remove the light bulb and put in the fuse and retest the SMPS or equipment without worrying that it will blow the components because the secondary output voltages are already present in the secondary side.

If you get **very little voltage or no voltage** at all in the secondary side, I guess you might need to troubleshoot the SMPS again until you locate the faulty parts.

## How To Find Shorted Components Using The Series Light Bulb Tricks

If the bulb light brightly and did not go off, then by using the method below will help you to locate the shorted component fast.

Once you see that the bulb did not go off even **after a few minutes** (indicating short circuit in power supply) what you need to do is to turn off the power and pull out the AC plug and quickly discharge the big filter capacitor in the power primary section. Once you have done that then, place your finger on the semiconductors, SMPS transformer or any suspected component in power supply. The **hottest component** in the power supply is the one that had caused the bulb to light brightly because the shorted component consumes more current! Generally, components would only run warm and not hot. Replace the bad component (hottest) and retest it and I'm sure now the bulb would go dim/off.

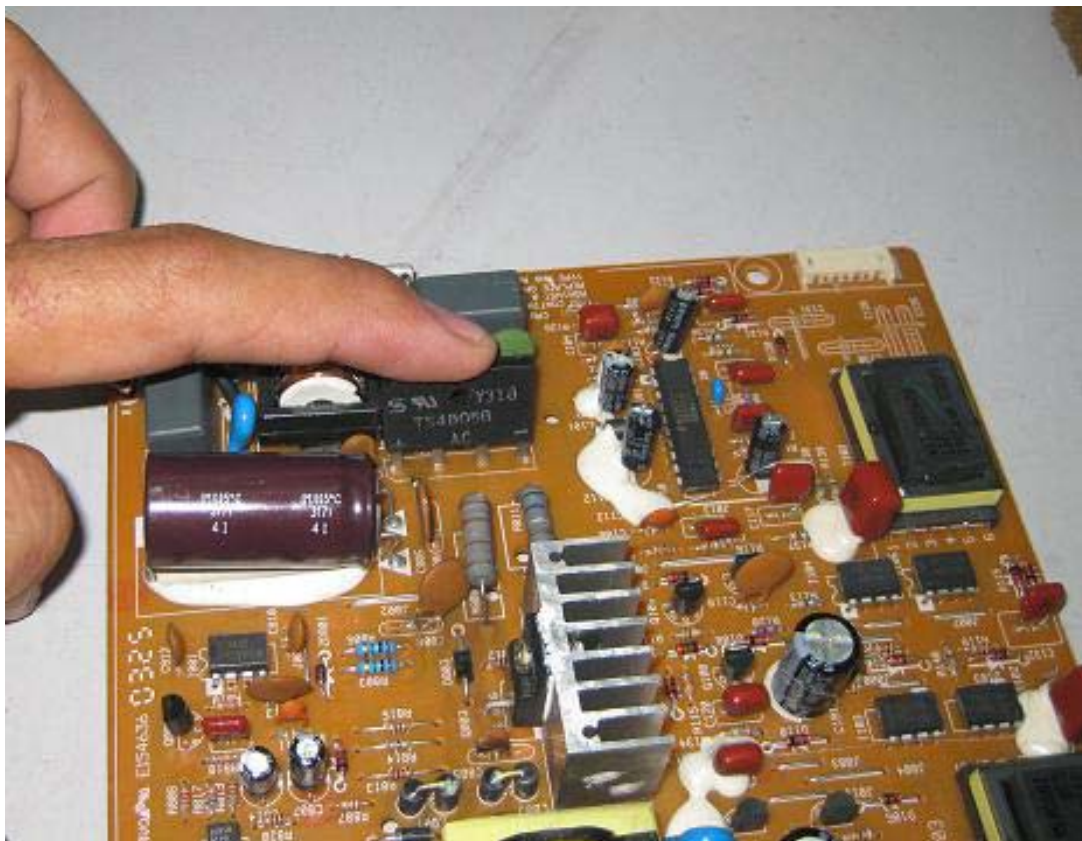
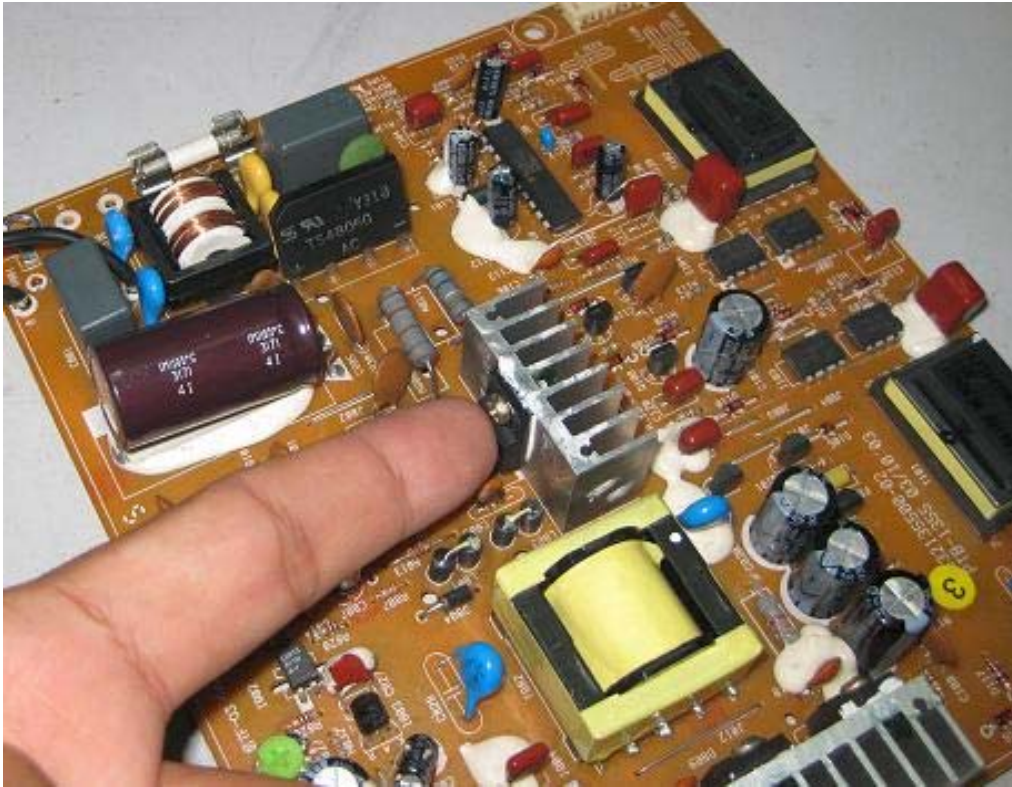


Figure 13.6- Touching The Bridge Rectifier



**Figure 13.7- Touching The Power Fet**



## **14) The Five Methods That I Use To Troubleshoot and Repair SMPS**

Everyone has his or her own way of repairing SMPS. I do not know about others but after so many years of being involved in the electronic troubleshooting line, I could conclude that the 5 methods that I had used for repairing SMPS were very effective in identifying fault in the power supply section.

If you repair a SMPS and found the following problems namely: the electrolytic capacitors bulged, dry joints, cable loose connection, diode breaks into two, resistor burnt (or dark in color), decayed glue all over the board, Varistor and power FET split open, fuse glass and power IC cracked and etc you can easily conclude where to check for the problem because all these are physical failure where you can **see** it! That means if you see that the Varistor split opened, you can conclude that only that area is faulty and chances are very slim for the secondary side to be faulty. Your next step would be to concentrate in finding bad components in the corresponding area (Varistor circuit area). After you have replaced the bad components, you will begin to retest the power supply-**am I right?**

The problem now is after opening up the SMPS cover or the equipment cover, you **did not see any physical signs** of component failure and you do not know where to begin to check. The fault could be in the primary section, secondary section or could even be in **both sections!** If you don't know which section is giving the problem, then you will have a **hard time** to find out the bad components.

The five methods that I have used could help narrow down your search and you can conclude at which section is the cause of the problem. From there you can use your **testing electronic components knowledge** to locate the faulty components!

### **1 Using The Blue Ring Tester Method**

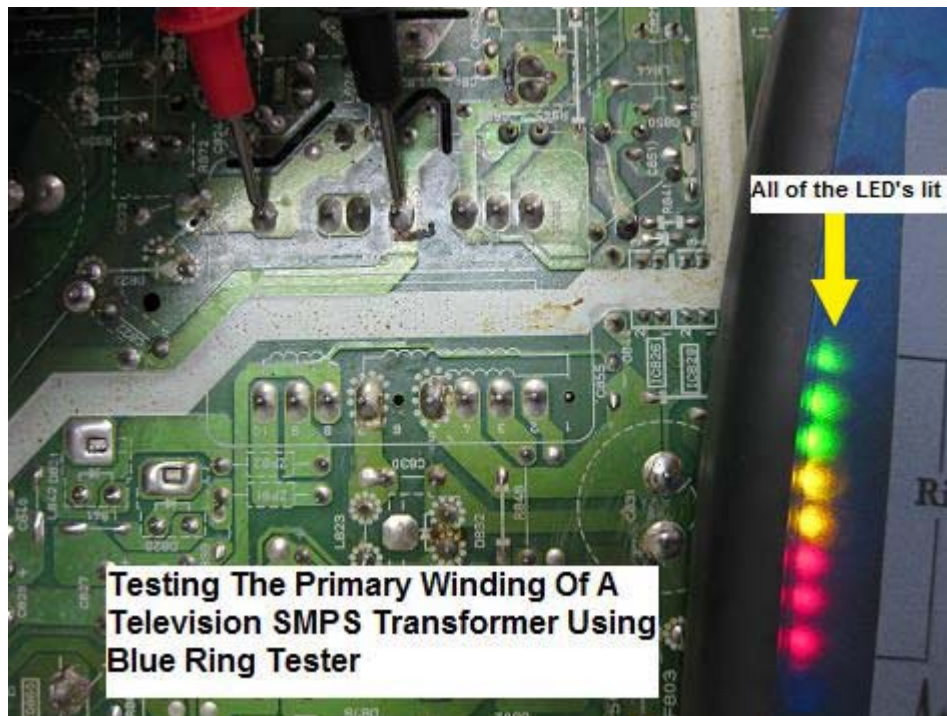
The switch mode power supply repair and troubleshooting are the most exciting circuits for a repair technician or engineer. It consists of primary and secondary section and has different types of components in it to make the power supply to work. If any components in either one of the section is found faulty (primary or secondary), it may cause the power to blink, no power, power shutdown or low power problem.

When problems occur in a power supply section, an electronic repairer must know how to troubleshoot it. There are many types of power supplies designed by different manufacturers and due to this; it is sometimes quite difficult for us to repair the power supply if you don't have the schematic diagram. Understanding switch mode power supply theory, tutorial or operation will make us better in repairing the unit. In this first method, I will show you a way to troubleshoot switch mode power supplies even faster.



**Figure 14.1- A Blue Ring Tester**

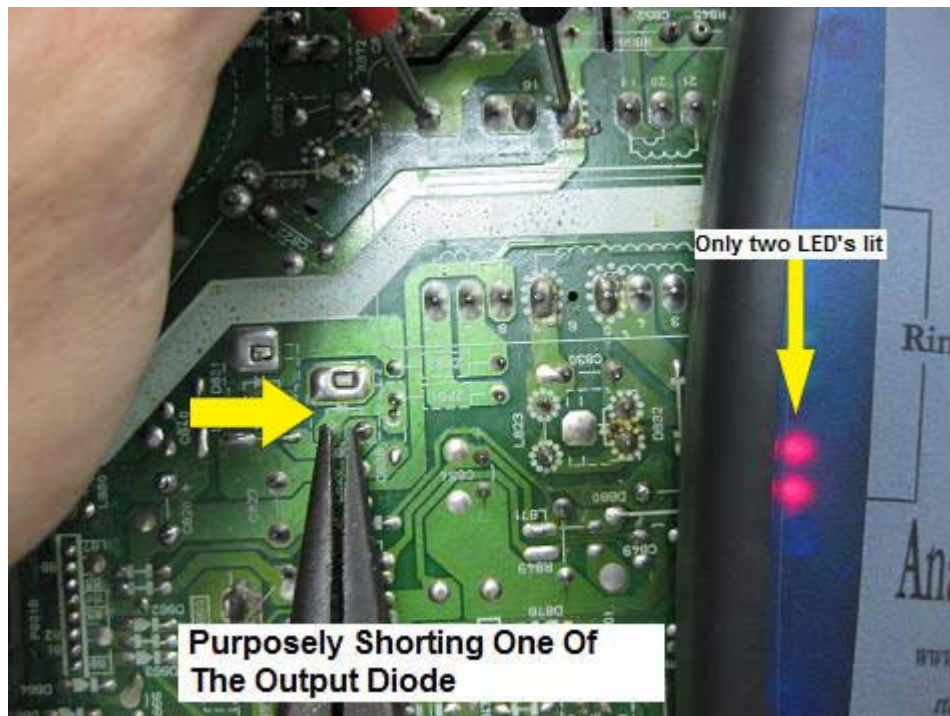
Normally, when an electronic repairer wants to confirm whether the secondary output diodes are working or not, he or she must desolder one lead of the diode and test it in order to get an accurate reading. Testing diode in circuit usually doesn't produce accurate result. By using the Blue Ring Tester, you can test the secondary output **diodes without lifting the diode from the circuit**. The Blue Ring Tester is very handy and versatile when it comes to finding fault in the primary and secondary section of a switch mode power supply.



**Figure 14.2- Full LED Lit From The Blue Ring Tester Indicates The Primary Winding And The Secondary Output Diodes Are Good.**

By placing the Blue Ring tester probes to the primary winding of the switch mode power transformer, a good measurement will usually indicate between 4-8 LED lights up. If it indicates only one or two LED or the tester LED goes off (no light), this prove that there are problems in the power supply. **The primary winding, Power FET and secondary output diode could have been shorted.** Make sure you have **discharge the large filter capacitor** and unplug the ac before placing the test probes. It is very simple to locate the primary winding of the switch mode power transformer. Connect one probe to the drain (centre pin) of the field effect transistor (power FET) with the other probe to the positive side of the large filter capacitor. If you carefully trace the drain and the positive pin of the filter capacitor, it will eventually bring you **to the two pins of the switch mode power transformer.** These two pins is the primary winding of the switch mode power transformer.

A good primary winding will have 4 to 8 LED lights up. If you use a long nose plier to purposely short across one of the secondary diode at the secondary section of the power supply, you will see that the Blue Ring Tester LED will drop to very low (one or two LED lights up only) and sometimes all the LED's may even go off. Please refer to page 164.



**Figure 14.3- Fabricate The Short Circuit By Shorting One Of the Secondary Diode To See The Result Of The Blue Ring Tester**

With this simple test, I believe you get the ideas of how this tester works. That means when testing the primary winding of the power supply and if you notice that the LED goes off-then suspect one of the diode in the secondary side may have shorted. If you get a 4- 8 LED lights up (depends on the power supply design) then you can conclude that all of the secondary output diodes, SMPS primary winding, Power FET and Power IC are not shorted. With this testing method, it can save you lots of time.

**Note: For CRT TV and Monitor repairers**

This **troubleshooting** method can also be used to test the primary winding of a flyback transformer. Sometimes a small secondary diode can go shorted at the secondary section of the flyback transformer (G1 or Vcc supply circuit). It can cause the switch mode power supply to blink, shut down when power on and low output power. It is important to check on all secondary output diodes and primary winding first before checking on other components. Troubleshooting and repairing switch mode power supply can be frustrating if you do not know the right way. If you do not have the Blue Ring tester, make sure you get one in order to speed up the repair. This section only explains one part of the way to repair switch mode power supply. Please keep on reading on the next four methods.

You may get the Blue Ring Tester from this website:

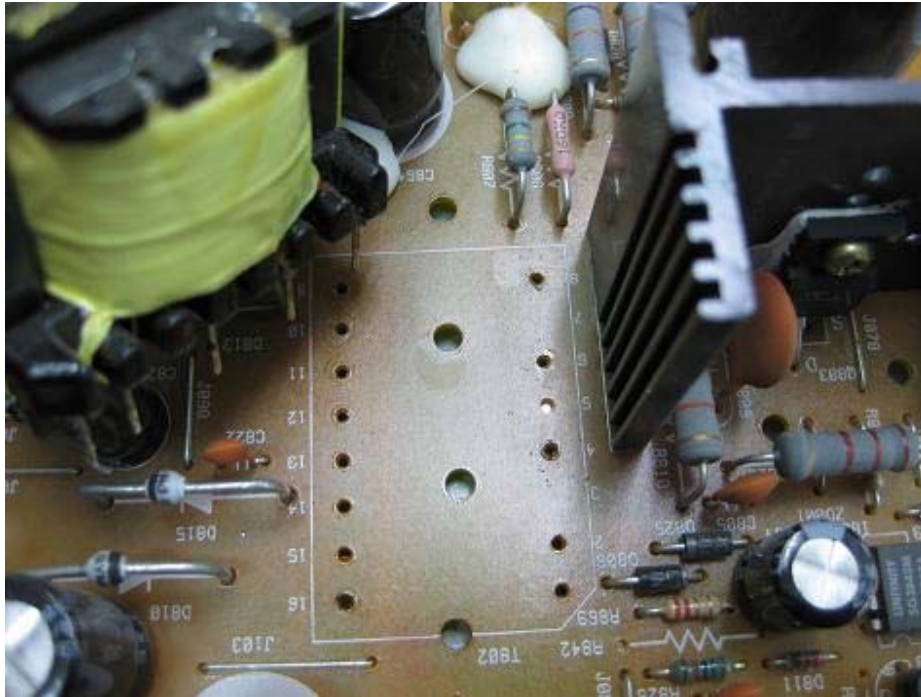
<http://www.electronicrepairguide.com/blue-ring-tester.html>

## **2 Flickering Method**

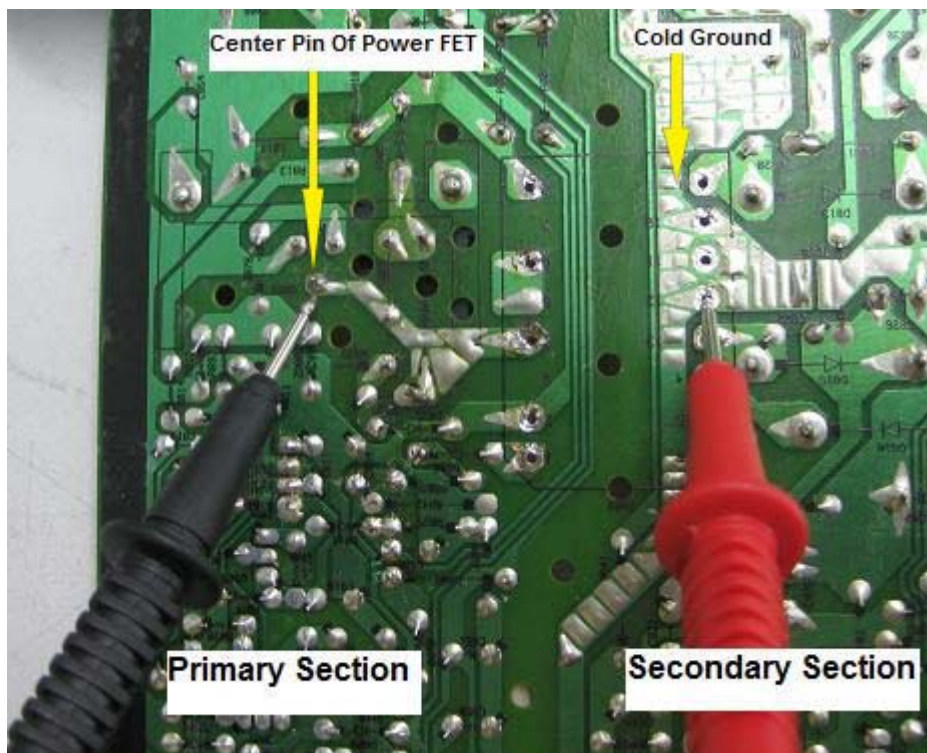
This method is used to find out whether the primary or the secondary section is the cause of the problem. Sometimes in SMPS repair, you just don't know where the problem lies. You might have checked many of the major components like power FET, secondary output diodes, Horizontal output transistor (HOT), FLYBACK, Yoke coils, B+ coils and etc and all seemed to be good. You need an absolute way to find out which section is actually given you the problem. Once you know which section is having problem then it will be easy for you to spend all your time on that section so that **you can easily nailed down the culprit.**

The first thing that you need to do is to follow the steps below:

- 1 Remove the SMPS transformer from the circuit (refer to figure 14.4)
- 2 Set the analogue multimeter to 50 VDC
- 3 Place the red probe to cold ground and the black probe to the point where the line is connected to the DRAIN pin (usually is the middle pin) of power FET (refer to figure 14.5). For those SMPS that do not have power FET, you can place the black probe to the drain pin of the power IC. You can find out the power IC drain pin from datasheet downloaded from the Internet. Sometimes the word "Drain" is written on the power circuit board.
- 4 Switch On the power and check to see if the needle/pointer of the analogue meter would flick or not (refer to figure 14.5).
- 5 If the pointer flicks then 95 % the primary side is good. If it doesn't flick at all (no movement) then suspect the primary side to be faulty



**Figure 14.4- Remove The Power Transformer**



**Figure 14.5- The Right Way To Place The Test Probes**



**Figure 14.6- Expect The Pointer Of The Analogue Meter To Flick**

**Note:** Not all SMPS will flick and some will flick higher than others. You need to test the result on different SMPS in order to familiarize with the flicking. In other words, the flicking is fully dependent on each of the design of the SMPS, be it in the CRT/LCD Monitor, TV, Stand Alone SMPS or etc.

If you have confirmed that the primary side is the cause of the problem then check all of the components in this area. Once you have located the bad components, replace it and retest to see if it flicks or not. If it is flicking, do switch off the power, discharge the big filter capacitor and reinstall the SMPS transformer and power on the equipment again.

**Note:** You can only power “ON” the SMPS after you have confirmed that the secondary side components have tested good especially the secondary diodes, and filter capacitors.

### **3 Resistance Test Method**

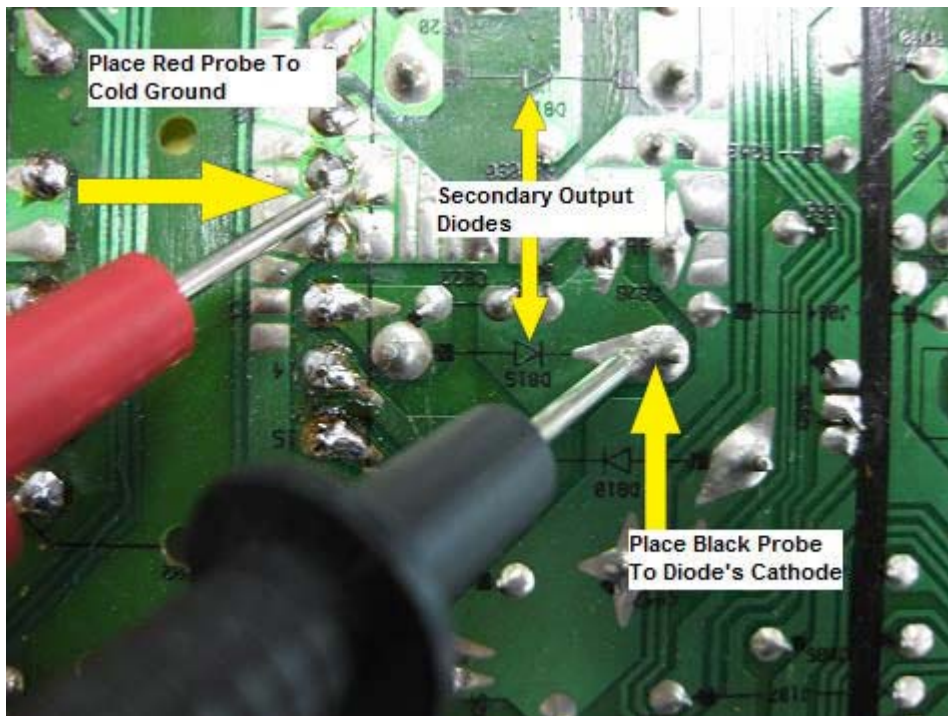
In troubleshooting and repairing SMPS, sometimes it can be easy and in other times it can be difficult to repair. The power supply faults can be caused by only one bad start up resistor and it can also be cause by more than ten bad components (heavy lightning strike). In this section I'm going to explain to you the power supply problems that are caused by defective components at secondary side. Sometimes a no power, power blink and low output power symptoms are due to the problems in the main circuit board (load). It is not necessary the power problem must come from the primary power section and shorted secondary output diodes.

The fault can be **further down** the secondary output line which is in the main board. If you have measured all the components in the power supply section and could not find the defective component, then try troubleshooting components **beyond the power supply section**. For your information a shorted small ceramic capacitor in the main board can cause the whole power supply to malfunction.

All SMPS have outputs at the secondary section. Some designs have four outputs, others five and so on. Each of the output is connected to an individual circuit. For instance, a 6.3 volt output supply is sent to the picture tube so that it could light up and heat the cathode gun. A 5 volt supply will usually enter into microprocessor and EEPROM IC as VCC supply, 45 to 100 Volts to B+ pin of flyback transformers and so forth. If one of the components or circuit develops a short circuit, it will draw lots of current causing the power supply to shut down, fluctuate; produce low output power or even no power at all. You must know how to isolate and repair the problem otherwise you will be **wasting your time finding bad components in the power supply section**.

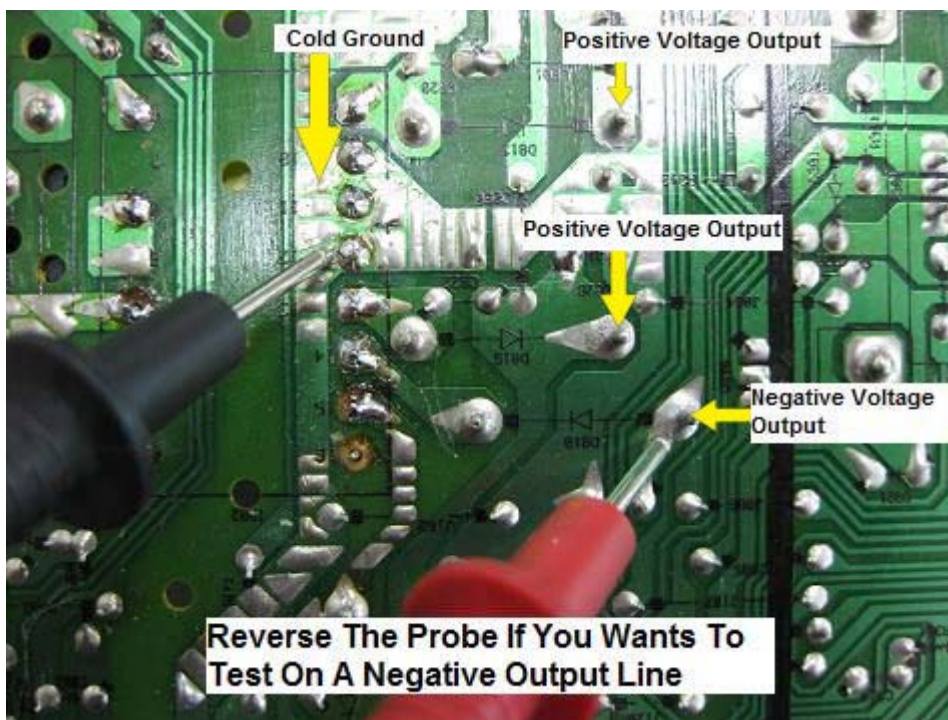
Set your analogue meter to times 1 Ohm range and check all the secondary output (after the secondary output diodes) between cold ground and **all the output voltage line**. Put your red probe to the cold ground and the black probe to each of the outputs of secondary diodes as seen in figure 14.7. It should have no reading or very high ohm reading and sometimes the pointer will kick up a little bit. **This is a normal reading for a good output voltage line**. The reason the pointer kicks up a little bit is due to the circuit board resistance and some undischarged voltage from the secondary output filter capacitor.





**Figure 14.7- The Right Way To Place The Test Probes**

If you are checking the negative output of the SMPS, then you have to reverse the meter's probe as shown in figure 14.8.



**Figure 14.8- Reverse The Probe If You Want To Test On A Negative Output Line**

**If any of the output voltage lines shows two same reading (low ohms readout), then suspect that there is a problem in that output line.**

Carefully follow the suspected output voltage line and gently remove components one by one at a time to isolate the short circuit. From my experience it is usually caused by a shorted IC, a transistor, a diode or even a resin type ceramic capacitor. If you are repairing a CRT Monitor SMPS, and if one of the output voltage lines shows two readings, please do not think that the line is having a problem. The reason you received two readings was because you are checking the filament (heater) circuit. The line goes to the picture tube's filament which is connected to cold ground. That is why you have two readings.

**Note:** Please don't set your analogue meter to times 10 Kilo ohm range or otherwise all the readings that you have measured will show two readings which are not accurate. The X10 K Ohm range is just too sensitive for this kind of test!

#### **4 Isolation Method**

Do you know that whenever an equipment has the following problems; namely such as no power, power blinks, low output power and etc, it was not really caused by the SMPS itself? Yes, there is also a possibility of the load problem that has drawn too much current that had caused the SMPS to have problem. In other words, it is the external factor problem that prevents the SMPS from functioning properly. If you did not perform the isolation test you may be wasting your precious time in finding the fault in the SMPS because the fault is actually **in the load**.

One of the important steps in troubleshooting SMPS problems is to **separate** the SMPS output from the rest of the circuit. This would surely help you to determine if the SMPS problem is due to the SMPS itself or caused by the load problem.

Let's take the dot-matrix printer for example. The dot matrix has a power board and a main board. If the complaint was no power (power LED doesn't light up) and you got zero voltages measured at the secondary output, the next thing you should do is to remove the connector between the power and the Main board. This **will separate** the connection between the power and the Main board. Now, retest the power supply output with your digital voltmeter and if you got back all of the output voltages then we can conclude that the Main board had dragged down the output voltages (possibly some direct short circuit components in the Main

board). If the output still remains zero volts, then suspect the problem in the power supply board.

Note: In some SMPS design, a SMPS would not run without a load (Main board)! The SMPS will shutdown immediately upon detection of no load. If in this case, you could use an analogue meter and place the red probe to one of the output line of the SMPS and the black probe to cold ground and power On. If you could see the movement of the pointer moving up and then go back to infinity again. Here we can conclude that the power supply is trying to come up but because of no load condition, the power supply shuts itself off. Chances are high the power supply is good. If there is **not a single movement** from the pointer, we can conclude that the power supply is the problem. Remember, you have to practice on a few tests on different power supplies before you could come to any conclusion.

For a printer, it is easy to separate the boards but what about Monitors, TV's and other electronic equipment? Here I will show you how to separate the Monitor power supply from the load and how you can use this method to **apply to any of the electronic equipment** you are repairing. You have to be creative in **finding a suitable load** for the power supply you are repairing.

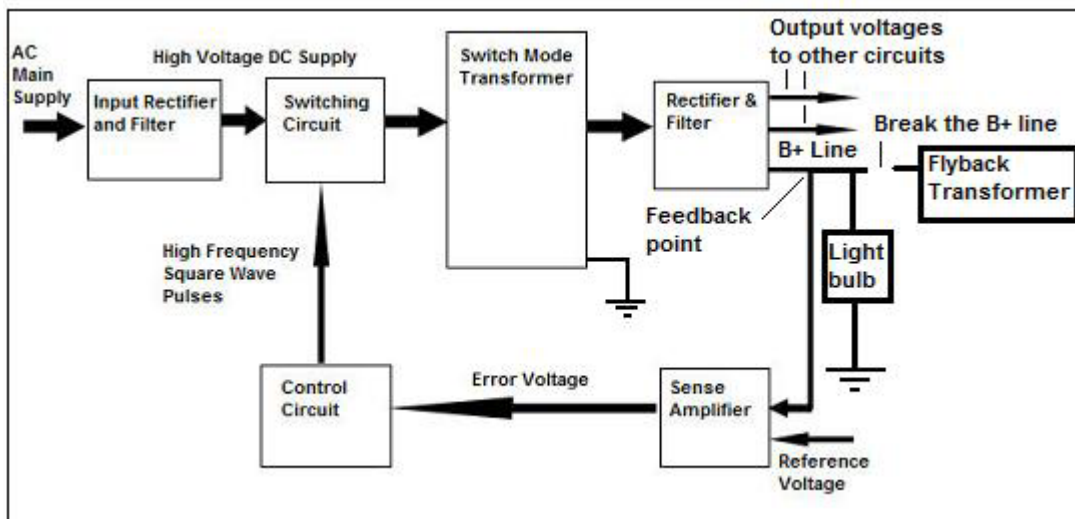
In repairing CRT Monitor, I have come across power problems where I have to separate the circuit so that I know where the problem was coming from. That is whether from the power supply itself or from the load (high voltage section).

- 1) First, identify the B+ line (about 45 to 100 over volts, depending whether it is a boost or buck circuit).
- 2) Once found the B+ line then break the circuit after the feedback point by removing the B+ coil.



**Figure 14.9- A Typical B+ Coil From CRT Monitor**

3) Next, connect a 100 watt bulb between the B+ line and cold ground as shown in figure 14.10 below.

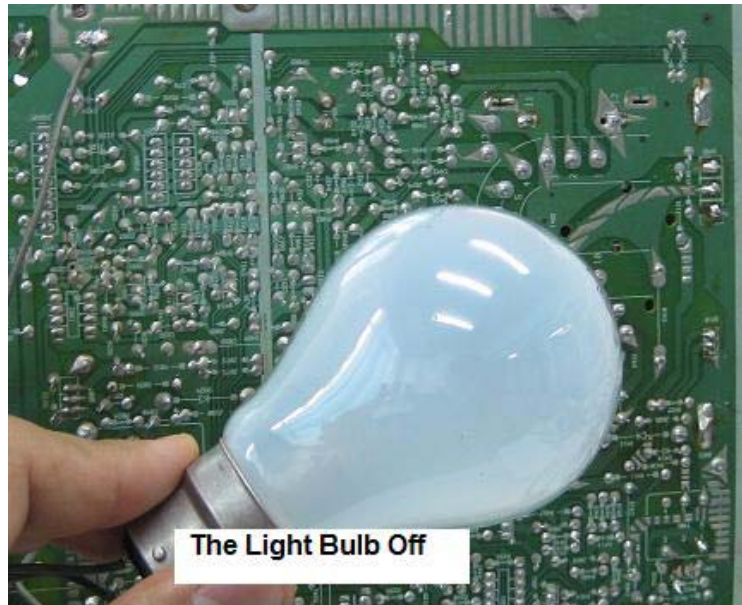


**Figure 14.10- The Right Way To Place The Light Bulb**

4) Power On the set and see the result of the light bulb

There are five possibilities that can be expected from the light bulb

- a) The light bulb lits with a constant brightness and all of the output voltages measured normal at the secondary side of the power supply. (This indicates that the SMPS is working fine and the cause of the power problem is in the load-so **your concentration** is to find the faulty components in the load area. It could be a shorted flyback transformer, yoke coils, horizontal output transistor and etc.
- b) No light from the light bulb and no voltages measured at the output of the power supply (This indicates the problem is in the SMPS and your concentration **should be in the SMPS** and not in the load)
- c) The light bulb comes on and then goes out (This could indicates the power supply shut itself off after finding out that the substitute load (light bulb) resistance was not enough. Sometimes this could also indicate the power supply itself has problem because it can't sustain the output power drawn by the load due to some components failure in the power supply like a bad filter capacitor, current sense resistor turn into higher ohm and etc.
- d) The light bulb becomes extra bright and all the output voltages have increased. This indicates the problem is in the regulation circuit like an open resistor in feedback circuit, bad Optoisolator IC, faulty TL431 IC and etc. Put your concentration in the feedback area and don't waste your time on the load area.
- e) The light bulb keeps cycling (continuously On and Off). This could indicate problems in the SMPS area and it can also mean the CPU IC is sending **an error signal** to the primary circuit of power supply through Optoisolator IC causing the power supply to cycle. When a flyback transformer is energized it will generate voltages to various circuits. If the flyback transformer circuit has been substituted by a light bulb, then no voltages will be generated by the flyback transformer and no signal will be sent back to the CPU. Because of this, the CPU will **generate an error signal** to the Optoisolator IC and this will cause the output power to cycle. If the equipment has a simple design (without using an Optoisolator IC) and does not have CPU to control the power circuit, whenever there is a power cycling problem, chances are very high the **power supply itself** is the problem.



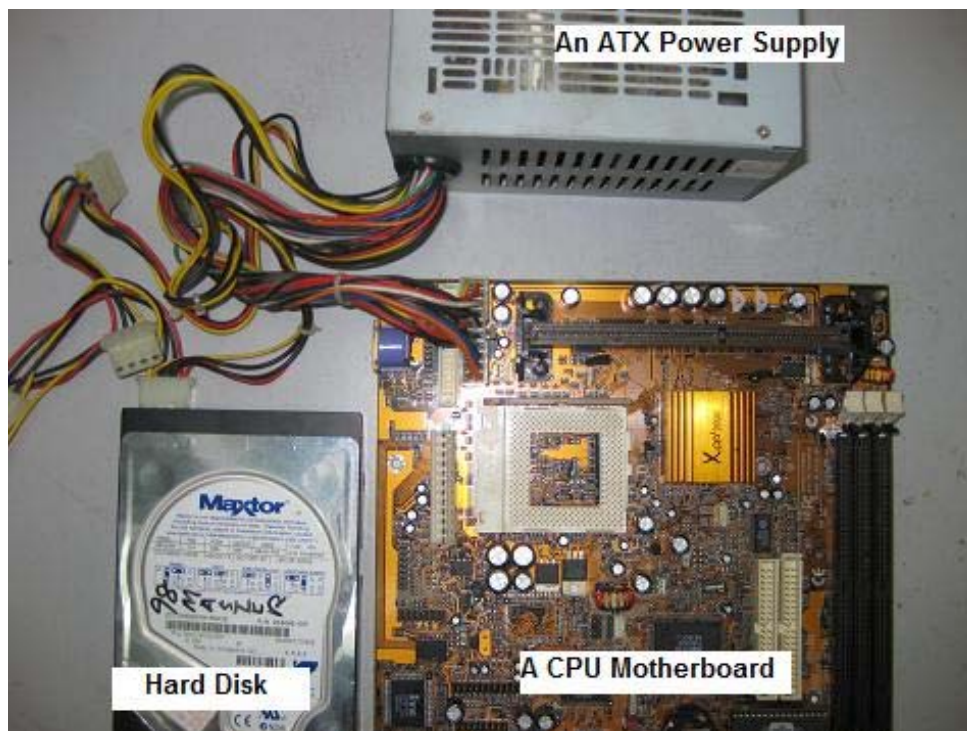
**Figure 14.11- The Light Bulb Is OFF**



**Figure 14.12- The Light Bulb Lits**

It can be very subjective sometimes by connecting a light bulb to substitute as a load for a circuit due to too the many designs in SMPS. The best way to familiarize with the isolation method is by connecting the light bulb on good equipment and observe the behaviour of the SMPS. The experience that you have gained could easily help you to judge which power supply section that has the problem. The isolation method explained above can be used on other electronic equipment as well. So what about the ATX power supply and the Stand Alone type SMPS?

## For ATX Power Supply



**Figure 14.13- Connecting ATX Power Supply To Load**

Always test an ATX power supply with a used PC motherboard to act as a load. You can add in a few used hard disk drives to add in more loads just in case if the ATX power supply would not turn On **with less load**. You also have to understand that in certain brand of CPU, the ATX power supply only works with the **original Main board** and would not work on any other PC motherboard. It will cause the fan to rotate for a few turns before it stops. By connecting back the ATX power supply to the original Main board, it would cause the power supply to work again.

## For Stand Alone Type Of Power Supplies

Most of this type of power supply would work even though there is no load. The output produced is very stable and you can directly measure the output voltage using your digital multimeter. Just in case if the power supply shutdown due to no load condition, you can always add in an extra load to test the power supply. If you know that the output power supply is 18 Volt, then you can place a 24 Volt automobile brake light to act as a load.



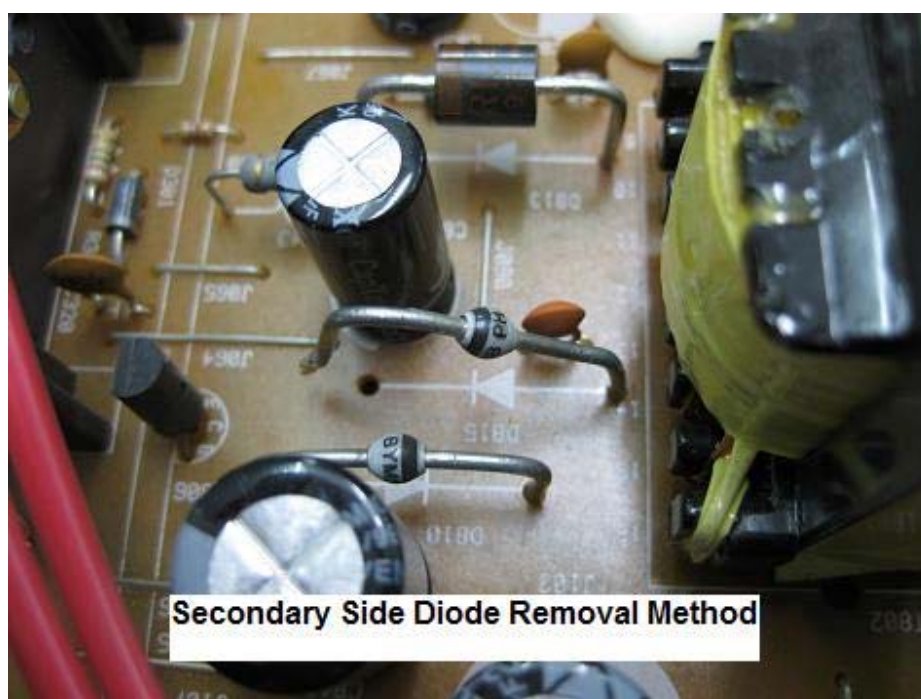
**Figure 14.14- Use A 24 Volt Automobile Light Bulb As Load**

Connect the bulb between the output voltage point (18 Volts) to cold ground and power On.

**Note:** Because there are thousands of SMPS model in the market, you have to use the best method to test the SMPS. You can use a light bulb, a dummy load with resistors, a used Main board and etc to find out where the fault is so that you could speed up your troubleshooting work.



## 5 Secondary Diode Removal Method



**Figure 14.15- Remove One Secondary Diode First And Retest And If The SMPS Still Not Working Then Remove Another Diode**

This is also one of the ways to isolate problem in SMPS circuit. The function of the secondary output diodes is to convert the AC to DC voltages and supply to all the necessary circuits like the vertical, color, high voltage, EEPROM IC and etc. If one of these circuits developed a short circuit, it could draw lots of current and this would shut down the power supply or even could cause the power to blink and produce low output voltage too.

Lets take the example of Vertical output IC that is **partially shorted** and this could not be detected by using the ohmmeter. If it is a direct short circuit then you can use the ohmmeter to locate the fault (refer to the resistance test method in page 168). For your information this partial short circuit in the Vertical output IC could cause the power supply to stop functioning.

Since there are a few output lines and we do not have clues on which line is shorted, what we do here is to remove one by one of the secondary output diode and retest the set and hopefully it will work. If by removing one of the output diode and we got back the power or the power does not blink anymore, we could conclude that along the output line (or the circuit) there may be some components that have shorted. Now you can

concentrate your troubleshooting and find out the fault along the supply line up till the respective circuits.

**Note: Do not remove all secondary output diodes and power On.** This would cause overvoltage in the primary side (because no load at the secondary side) and blow the primary side components. I have blown a few units of the Monitor SMPS and I don't want you to follow my path.

## **15) Simple and Powerful Method That I Use To Troubleshoot And Repair Any Types Of SMPS**

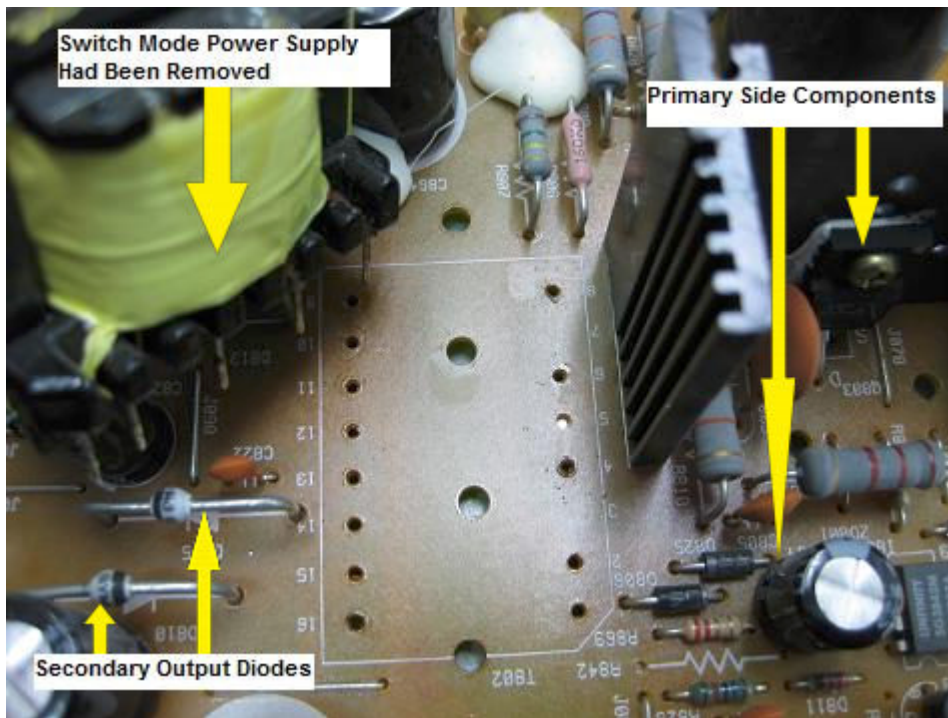
The first rule for every beginner to successfully troubleshoot and repair any type of SMPS is that they must have the skill of testing electronic components. If you want to know more about testing electronic components you can visit this website at <http://www.TestingElectronicComponents.com> . In the Testing Electronic Components ebook I have covered lots of testing electronic components information such as how to test AC/DC Voltages, how to discharge capacitor before you begin to work, the right method to test electronic components and many more. There are few more bonuses that can instantly boost your confidence in electronic repair. In this SMPS repair book, I actually presumed that you already know how to test electronic components and perform some basic repair.

No matter what type of SMPS that comes in for repair, one must always ask first, what is the problem with the SMPS? From there, you can make some conclusions as where to begin to check first i.e. the primary section or the secondary section? The problem is you have never repaired any power supply before and you do not know where to start or how to start. The problem could be no power, low output voltage, high output voltage, power cycling or etc. Do not worry because in this chapter I'm going to show you a powerful method (which I always use) that can help you to solve almost 80% of power supply problem-let's start!

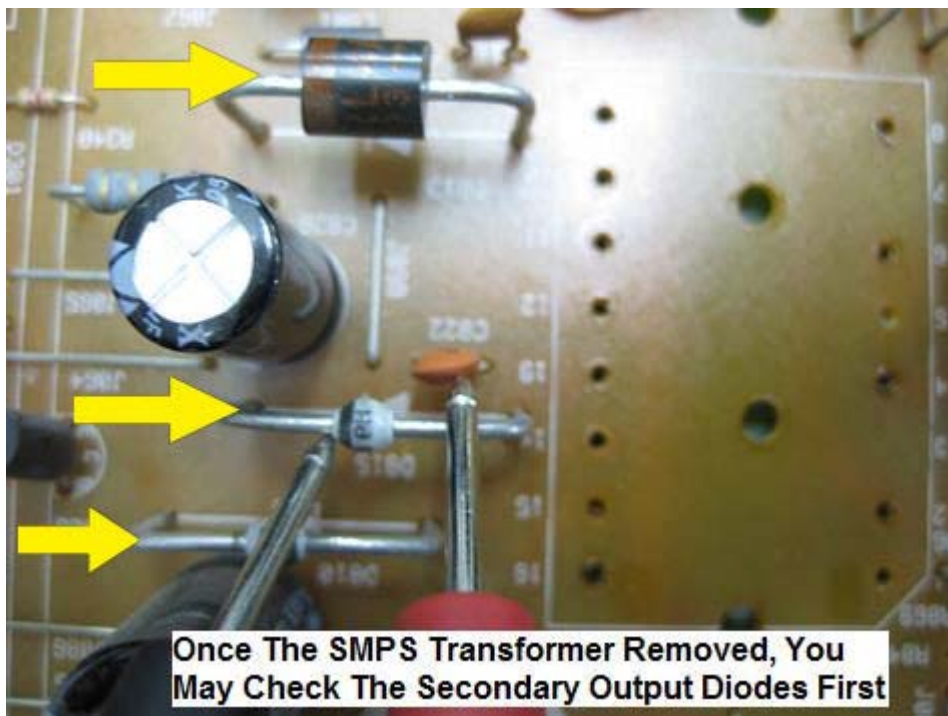


**Figure 15.1- Discharge The Big Filter Capacitor With A 2.2 K Ohm 10 Watt Resistor Before You Start To Test On The Primary Side Components**

The first thing that you need to do is to unplug the AC cord and discharge the big fat filter capacitor. Once the voltage in the capacitor has been discharged you then can start the troubleshooting work. Next, **remove the switch mode power transformer from the board** so that you could clearly see the primary and the secondary section of the power supply. Normally, I would begin to test on the components in the secondary section such as the secondary output diodes and the filter capacitors as seen in figure 15.2 and 15.3 in the next page.



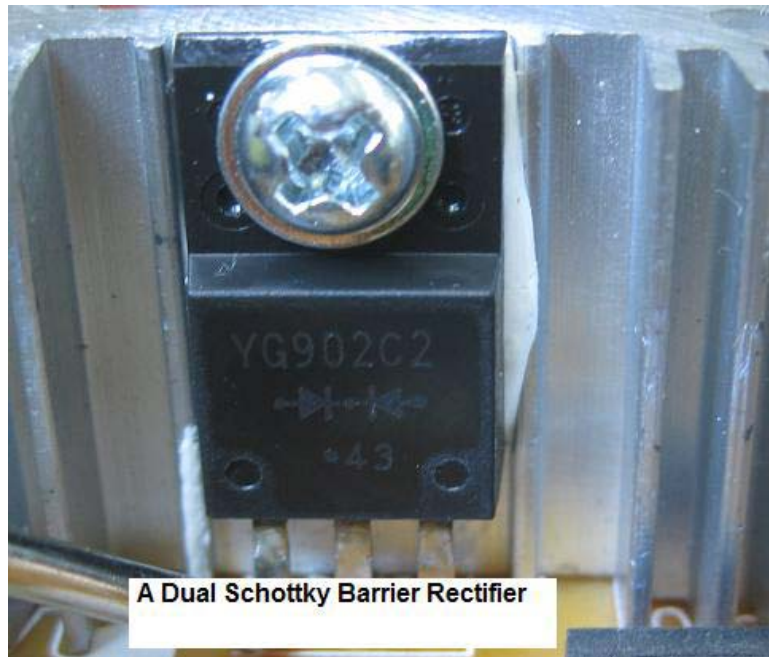
**Figure 15.2- Removal Of SMPS Transformer**



**Figure 15.3- Follow The Method And Test On The Secondary Diode**

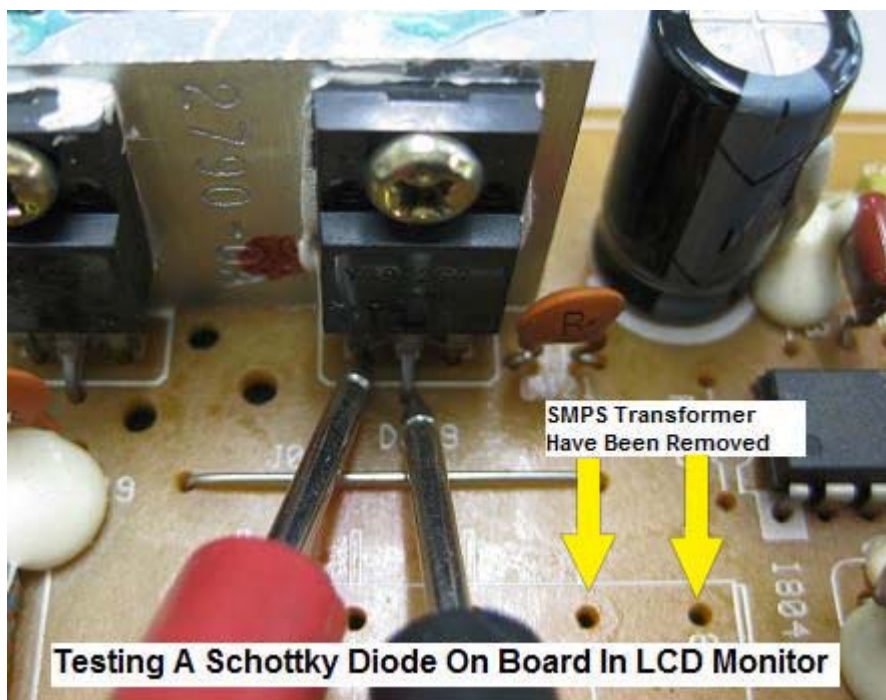
In order to accurately test the diode, first you need to select your analogue meter to X1 Ohm to test and then to X10 K Ohm. Both tests should have only one reading. The reason to test the diode using the X1 Ohm range is because **some diodes could show open circuit at X1 Ohm but tested**

good at X 10 K Ohm. If you only test the diodes with X 10 K Ohm, then you will miss out the leaky diode that can be leaked at X 1 Ohm range.



**Figure 15.4- A Dual Schottky Diode**

Some power supplies used Schottky diodes and testing it at X10 K ohm should have two readings but not shorted reading.



**Figure 15.5- The Right Way To Test Schottky Diode On Board**

**Note: When test the Schottky diode on board, the power transformer has to be removed first from the power supply otherwise you may not get an accurate reading.**

A shorted diode in this section will usually cause no power or power cycling/blink problem. A leaky diode will cause low output voltage and power shutdown problem. Sometimes, a leaky diode will also cause no power and power cycling too. Replace the bad diode and retest the power supply and make sure all of the output voltages are within the specification.

Once you have confirmed all the diodes are good, the next test will be on filter capacitors (electrolytic capacitors). The best test equipment to test the filter capacitors is to use an ESR Meter. If you do not have this meter, I strongly recommend that you get one so that you could speed up your repair work and save your time. For more information about ESR meter you can visit my webpage at <http://www.electronicrepairguide.com/blue-esr-meter.html>

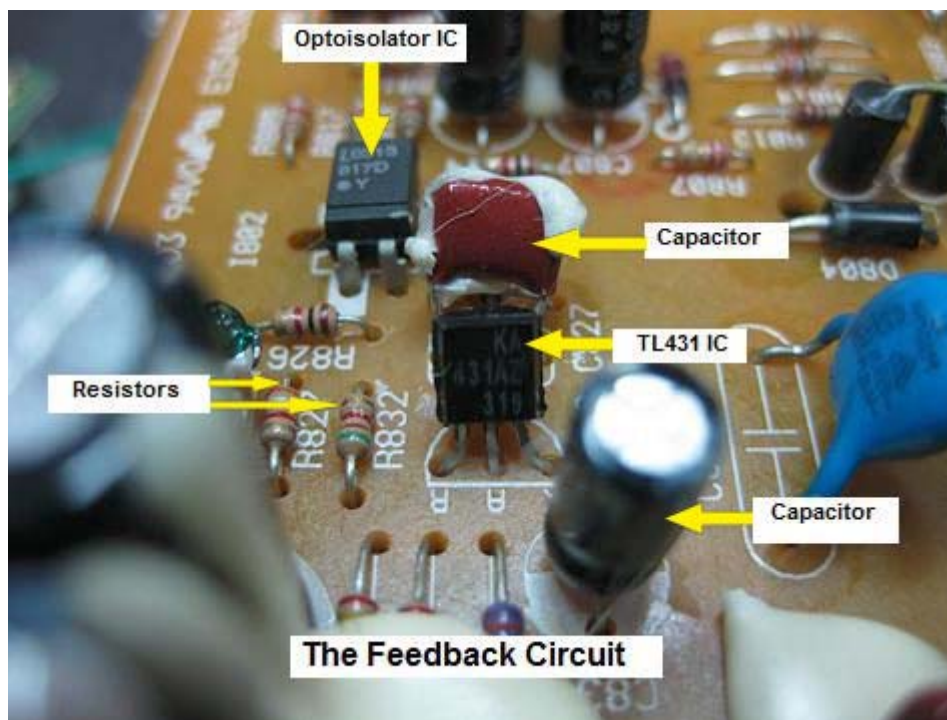


**Figure 15.6- Blue ESR Meter Can Be Used To Test Filter Capacitors On Board**

With the help of an ESR meter, we can easily test all electrolytic capacitors on board without having to remove the capacitors from the circuit board. This will surely save our time and if all filter capacitors are

tested good, you can begin to check on other section which is the **Feedback circuit**. A bad filter capacitor will cause low output voltage and power cycling/blinking. By the way, if you found a capacitor that is already leaked and bulged, your next action is **to directly replace** the capacitor even though sometimes it may be tested good (marginal capacitor) with digital capacitance meter or even with ESR meter! Now you have completely finished testing the **two major components** in the secondary side of power supply-**isn't that easy?**

Another section that we need to check before proceeding to the primary side of power supply is the **feedback circuit**. Some power supplies do not have the feedback circuit, thus by **checking all the diodes and the filter capacitors in the secondary section** your job is considered done. Now you need to move on to the primary section. Assuming the power supply that you are repairing have the feedback circuit, what you need to do is to check **all the electronic components** in the feedback circuit.



**Figure 15.7– SMPS Feedback Circuit Consist Of Optoisolator IC, TL431 IC, Resistors And Capacitors.**

First, test the resistors surrounding this circuit because an open resistor could cause output voltage to become high and shutdown. It may also cause low power and power blinking too. Some power supplies design used five colour bands resistor in the feedback circuit thus you **have to use a digital meter to accurately test the resistor value**. If the five

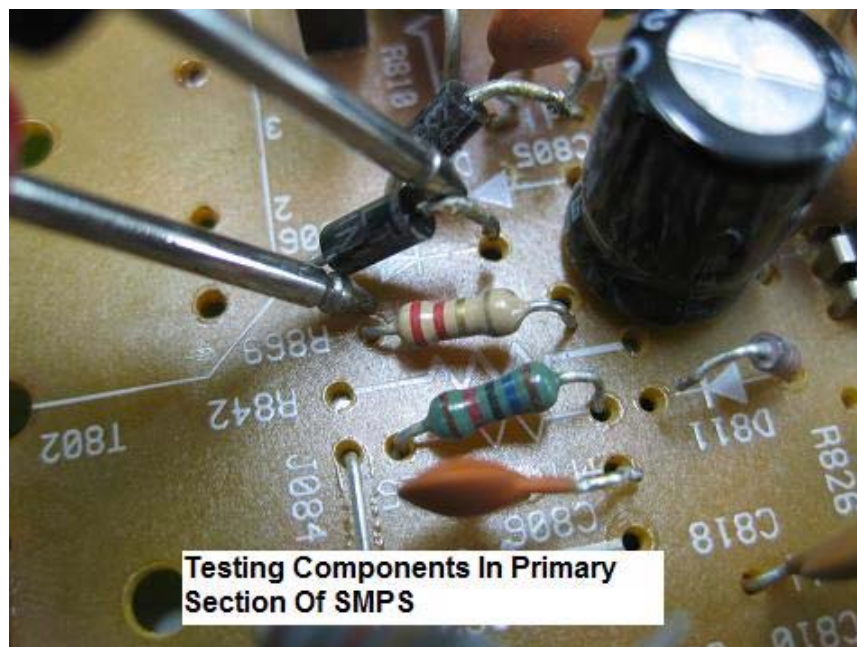


colour band resistor increased from the original value, you have to replace the resistor. Resistors value in this circuit is considered important because a small change in the resistors value could cause the power supply to shutdown!

There are some capacitors in this circuit that need to be checked. If it is a non polarity capacitor, then use a digital capacitance meter to test it and if it is an electrolytic capacitor, you have to use ESR meter.

For your information, there are two common IC's that are used in this feedback circuit. They are the Optoisolator IC and the TL431 adjustable shunt regulator IC. The Optoisolator IC can be tested with an analogue multimeter. Inside the Optoisolator IC, there is a LED diode and a transistor and if you have the internal diagram of this IC, you can actually test both the components in the IC. As for the TL431 IC, the best is to **directly replace** the IC and retest the power supply. Either one of the IC fail would cause no power, power cycling or low output voltage problem.

Now if you have completed checking the components in the secondary side, move on to test the components in the primary side of the power supply.



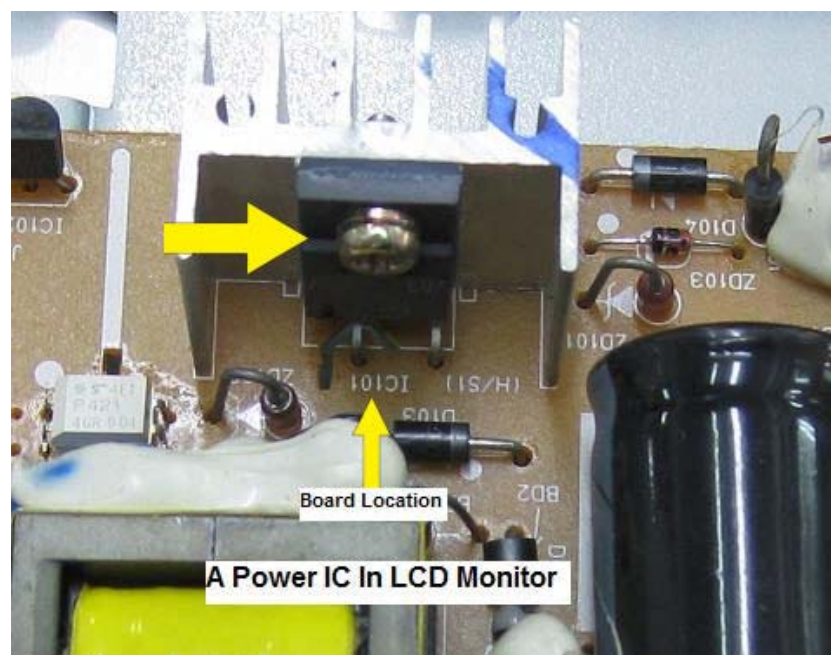
**Figure 15.8- Solder Out All Components In Primary Side And Test Them With Your Meters**

Checking the primary section is easy, just solder out all of the electronic components and test one by one until you have found the bad or the

defective components. What I mean to “solder out” is that you remove at least one lead of the components like resistors, diodes, zener diodes and etc so that you can perform an **accurate test** on these components. Checking the components on board would not give you an accurate reading due to **parallel circuit**. For example, instead of getting 47 Ohm when checking the resistor off board (with one lead solder out from the board), you get 15 Ohm which is not accurate when you tested it on board.

Power supply primary side problems can be caused by an open resistor, shorted diode, shorted zener diode, open non polarity capacitor, high ESR value in electrolytic capacitor, open fuse, defective power IC, shorted bridge rectifier, leaky or shorted transistor (bipolar or FET) and etc. If you are good in testing electronic components, you can completely check all of the electronic components in the primary side in **less than 20 minutes!** If you did not find any bad components in the primary section, then suspect the power IC. Directly replace the power IC and retest the power supply. Usually the power supply will work since you have confirmed that all of the primary and the secondary components are good!

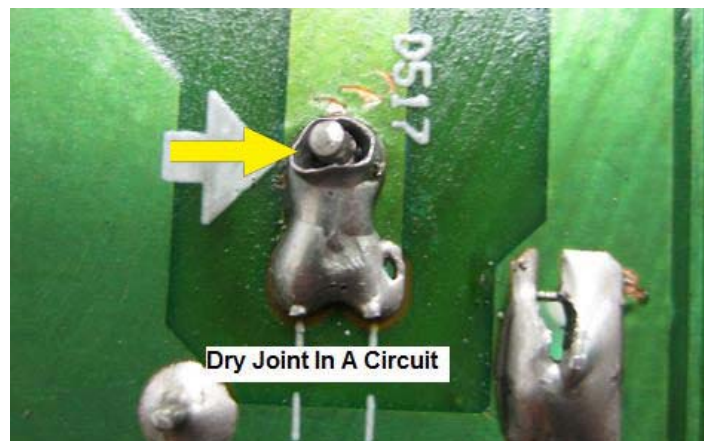
Note: If you are not sure which one is the power IC in the primary side, then look at the board location written as “IC”. In the photo below, the power IC labelled as IC101. You can use the Internet to search for the part number in order to confirm that the component is indeed an IC.



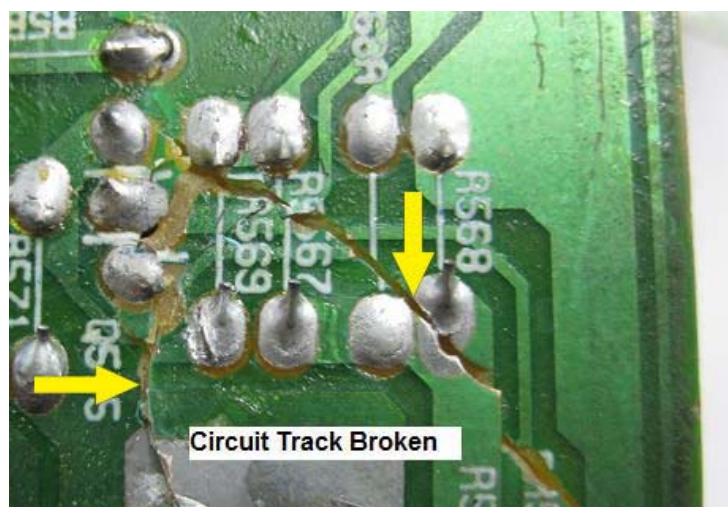
**Figure 15.9- A Typical Power IC In LCD Monitor**

Do you know that there could be more than one bad component in the power section? You will find lots of components burnt especially if the power supply hit by lightning or by a power surge. The fuse, bridge rectifier, current sense resistor, power FET, zener diode and power IC could blow and this will usually take you about an hour or so to complete the troubleshooting job. In certain cases, you can solve the power problem in less than few minutes because there is only one component found to be faulty! For your information, the primary winding of Switch **mode power transformer** can be shorted and you need the Blue Ring Tester to test it.

Besides electronic components, you are also required to check for dry joints in the circuit, decayed glue that can cause electronic components pins to become rusted, circuit tracked broken and etc.



**Figure 15.10- Look For Dry Joints In A Circuit**



**Figure 15.11- Check That The Board Did Not Crack**

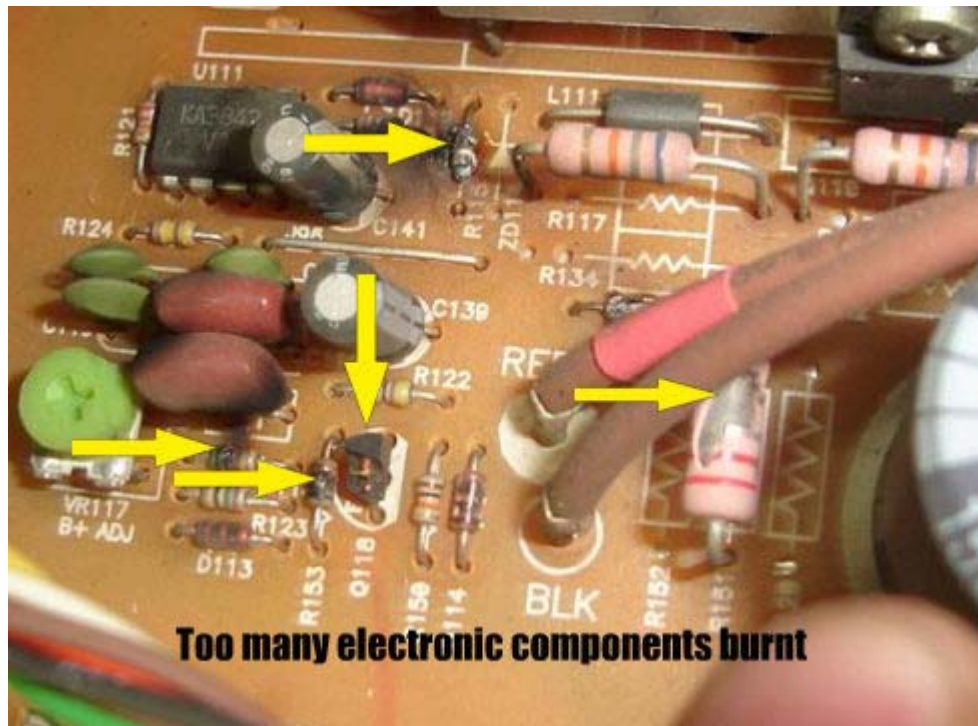


**Figure 15.12- Decayed Glue Found In Circuit Board**

You need more practice in order to perfect your skill in repairing SMPS. In order to speed up the repair work, **you must know** how to accurately test electronic components.

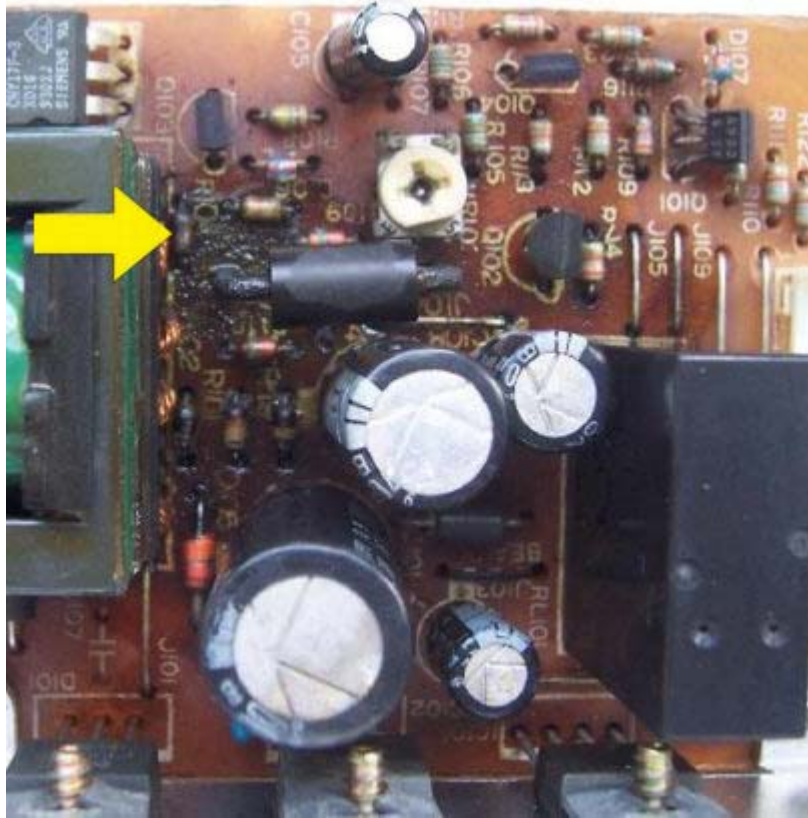
This chapter is written for beginners and if you already good in repairing, you can always perform the voltage or signal testing to locate the fault. It is not necessary for you to check all the components in the SMPS board.

## **16) What Should You Do If Too Many Components Burnt In The SMPS?**

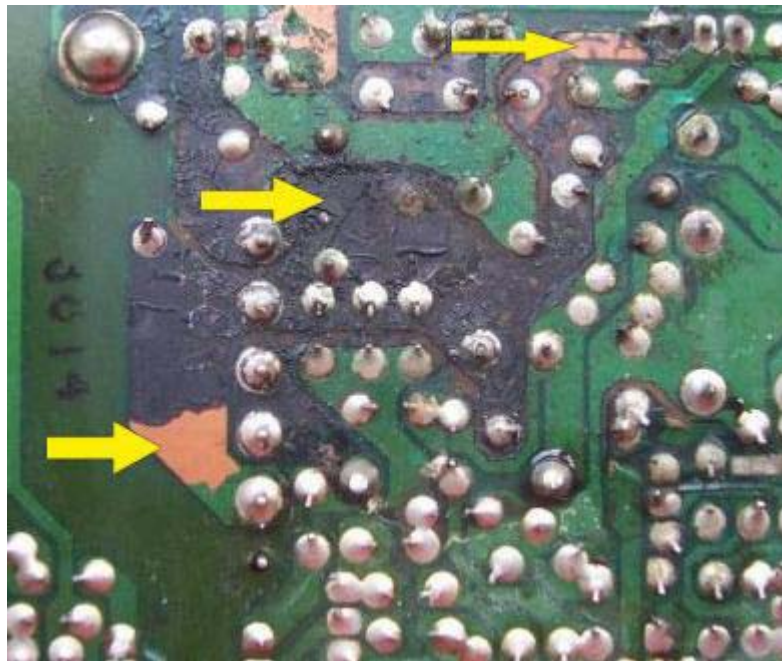


**Figure 16.1- Too Many Components Burnt In The Circuit Board**

For your information, not all SMPS that are sent in for repair have all the components intact inside the power supply. The components could break and burnt beyond recognition due to heavy surge and lightning strike. In some SMPS, the electrolytic capacitors may have leaked and because of this the electrolyte could cause the circuit tracks to be broken and rusted, making us have a hard time finding out the components part number. Please refer to figure 16.2 and 16.3 in the next page.



**Figure 16.2- The Damage Caused By Electrolyte**



**Figure 16.3- Rusted And Broken Circuit Tracks**

I have seen a dead lizard in SMPS before. The short circuit caused by the lizard blew up many components in the power supply. I also came across

missing components in the SMPS that had been repaired by dishonest technicians. They took out the good components if they could not repair the SMPS and because of this, we had difficulty in locating the component's original part number.

Assuming you come across such SMPS, what would you do? What is your decision? What is your next step? Repair or return the SMPS to the customer? **The reason I wrote on this subject is because I've gone through it and would like to show you how you can solve this kind of problem in a professional way, especially when dealing with a customer that have SMPS with such problems. You will definitely face this kind of problem either now or in the future.**

First, inform the customer about the problem in the SMPS and tell them that chances of it being fully repaired are quite slim due to the problems that I have mentioned above. Inform your customer that if it can be repaired, you will impose a higher fee for the time spent on solving the complicated problem (you can give them a flat rate charge-depending on the relationship between you and your customer-it's your choice!)

From the conversation between you and your customer, he or she could only give you a "YES" or a "No" answer. Some may say I will think about it first and because of this you may need to do follow up on the customer. If your customer says "No" then your next step would be:

Return the SMPS to the customer and impose a small diagnostic labour charge (again it depends on whether you want to charge the customer or not). That means you can straight away return the SMPS back to the customer if you have decided not to charge the customer.

If the customer says YES (meaning the customer agreed with the repair price) then there are the two things that you need to inform the customer:

**Time-** Let them know in advance that you need a longer time to repair the SMPS otherwise they would be calling you everyday (pressuring you) to ask about the status of the repair. This would surely frustrate you and you may regret taking up the job. There are customers who behave like this and you need to be sure the customer agrees with you first before you start with the repair work.

Another option would be to lend them an equipment (Monitor, TV or etc) to temporarily use first. This again depends on the trust between you and your customer. It also depends whether you have the equipment/SMPS in your workshop or not. In this way, you will have more time to repair the SMPS (or equipment) and are not subjected to the customer's pressure.

**Successful Repair Rate-** Inform the customer that the successful repair rate is not 100% as you are trying your best to make the equipment work again. Otherwise, if you can't repair the equipment then you will be in the hot soup. You have to inform them that you are trying your best to save the equipment and if it can't be repaired after many attempts then you will return the equipment to them.

Here are the steps that you need do in order to successfully repair the equipment:

### **1) Compare the Equipment/SMPS**

If you have the same equipment/SMPS, then you can try to compare the components and find out the exact value. I had compared lots of Monitor SMPS that have burnt components in it and managed to bring back many faulty Monitors 'back to life' again.

### **2) Authorized Service Centre**

You may send the equipment to any of the Authorized Service Centre for repair. They have all the repair history notes, schematic diagrams and spare parts for the equipment and could solve the problem in few hours time! Of course you have to expect that your profit margin will be lower because you have to pay for the repair fees to the Authorized Service Centre. Although the profit margin is lower, you have the advantage of time and you could use that time to repair other things in your workshop while the Authorized Service Centre fixing your customer's equipment.



### **3) Getting Help from Forums**

There is a good reason why you should join forums. Tell the forum members about the problem and sometimes you may get lots of suggestion on how to solve the equipment problem. Some members will even direct you to the exact location and suggest to you what to replace. You must join the right forum, whether it is a paid or a free forum.

### **4) Getting Help from Fellow Repair Friends**

I always encourage my readers to build up relationship with other fellow technicians so that whenever they have problems, they can discuss and share with one another. I would check from my repair friends to see if they have the same type of equipment in their workshop or not. Similarly, they would also call me to ask if I have the same equipment that they are looking for.

If I have it, I will give the information (value of the components) to them. The market is so big and I don't see my repair friends as competitors and there is no way you could conquer the whole market. Once in a while, some of them would visit my office and chat on the topic about electronic repair. I have benefited from those conversations and I would like you to do the same too.

### **5) Getting Schematic Diagrams**

Nowadays, there are tons of websites that offer free schematic diagrams to many types of electronic equipment. You can download the schematic diagram and find out the value. Some websites charge a small fee for getting a schematic diagram. The small investment not only could help you fix the faulty equipment, it can also be used in the future just in case the same equipment develops some other problems.

### **6) Buy Used Equipment from Ebay dot com**

I have repair friends who told me that they made good profit by buying junk equipment from EBAY DOT COM. The equipment was repaired and then they sell it to customers. Well, you can always follow their method if you want to but your purpose of getting those junk boards is to salvage the parts as a replacement for the equipment you are repairing. You could just swap the faulty SMPS with the good board you bought from Ebay or you can compare them to find out the components value. The rest of the good parts you can keep it for future use.

I hope after reading this topic, you will know what do to if you come across a SMPS or equipment that has burnt components in it.

**Note: In some cases like if the electrolyte leaked into the board, you can use thinner to clean the board and make sure the circuit track didn't break. Sometimes after cleaning the board, the SMPS will work again.**

## 17) How To Know If The Semiconductor Substitution Part Number Will Last Or Not?

If you come across a shorted semiconductor like transistor (Power FET, B+ FET, HOT and etc) or diode (bridge rectifier, secondary output diode, damper diode, modulation diode and etc) and you could not find the original part number from the market, what would you do? Obviously you will refer to semiconductor data book or even the Internet to search for the right substitution part number. Most of the data book will suggest few equivalent part numbers to use. For your information, **not all equivalent part number** can be used as some of them would short again after sometimes due to incompatibility in the semiconductor specification.

You would be frustrated as not only you could not repair the equipment; you are also wasting your precious time and money. I have a method to show you how you can know if the substitution part number can be used or not. The solution to the above problem is to use an AC ammeter. Figure 17.1 is the block diagram on how you connect the AC ammeter to equipment.

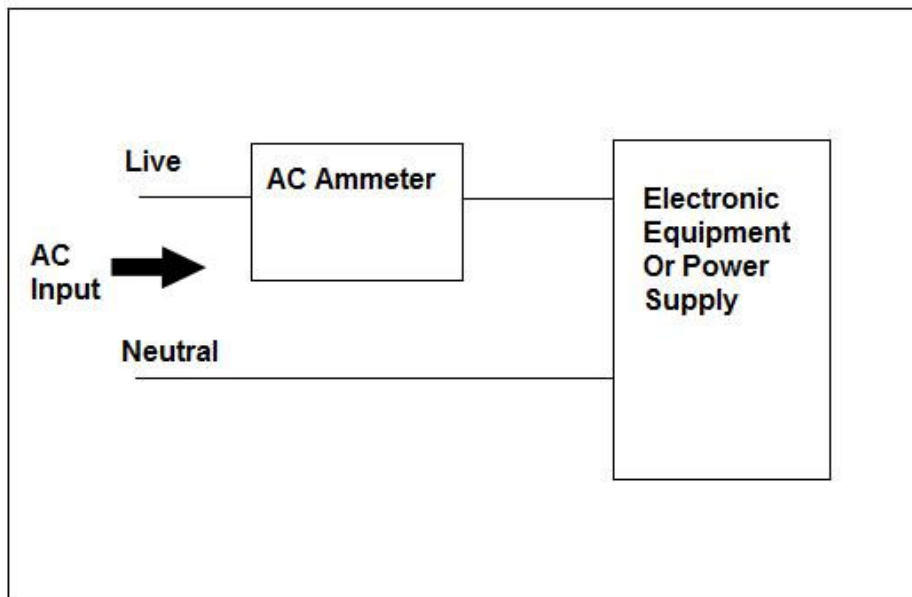


Figure 17.1- Block Diagram On How To Connect AC Ammeter To Electronic Equipment or Power Supply

If you want to put in the substitution part number in electronic equipment, I suggest that the equipment go through the test (by connecting the AC ammeter) so that you will know if the replacement part can work or not. There are two things to be observed from the AC ammeter panel after connecting the equipment with the AC ammeter.

1) AC ammeter has a constant reading (says .3 ampere) even after the equipment runs for many hours and under different types of testing (for example-testing a CRT Monitor under different resolution).

**If you get this kind of reading from the AC ammeter, you are now very sure that the replacement part number can be used.**

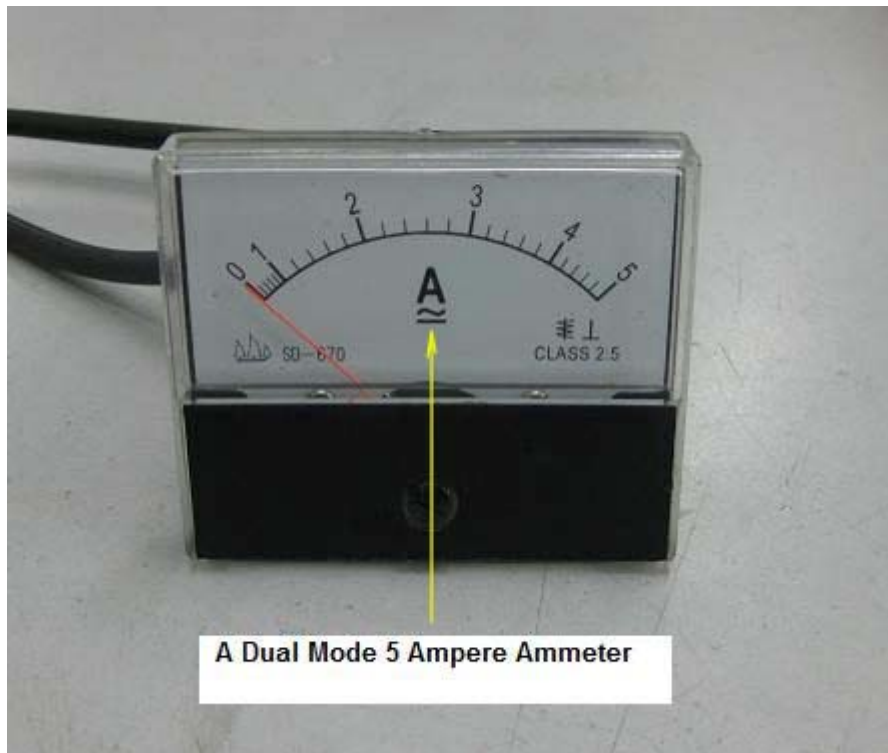
2) The pointer of the AC ammeter slowly moves up proportion to time. That means, the longer you turn on the equipment, the pointer will be moving far to the right side of the scale (the pointer could move slowly or fast depending on the substitution part number used)

**If you get this kind of reading this means that the substitution part number cannot be used and you have to turn off the equipment. If you did not turn it off, the replacement component will burn or short after a period of time. The reason why the pointer slowly moves up is because the replacement component gets hot and this will consume more current thus the AC ammeter pointer will slowly move to the right.**

**Note:** Usually, the replacement part number will slowly get hot before it goes shorted. In fact you can touch the replacement component with your finger to check if it hot or not. You can do this if you already removed the AC main and discharged the big filter capacitor in the power supply.

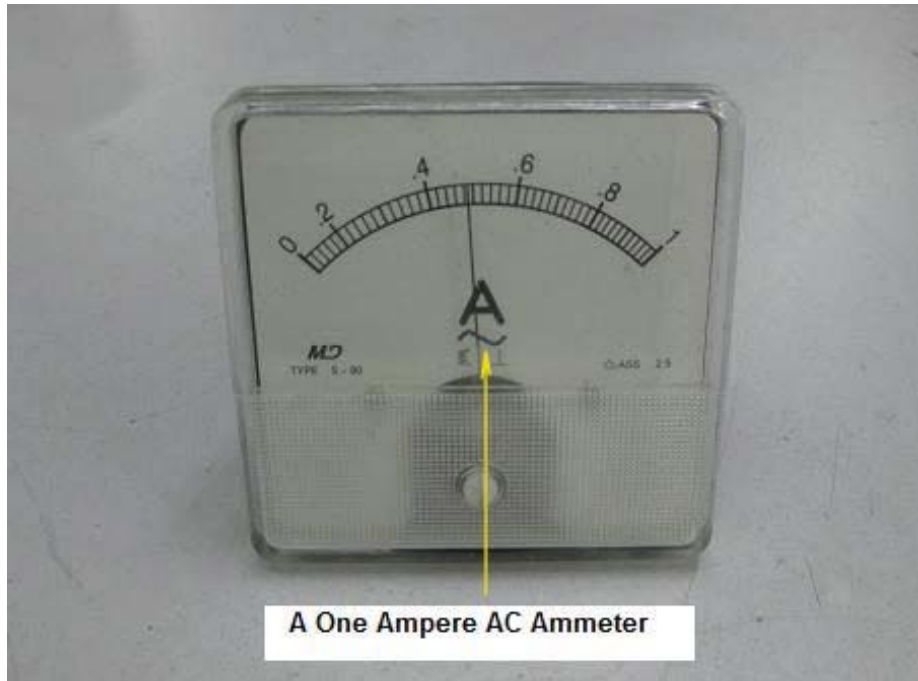
**Question-** What specification of AC ammeter should I buy?

You need to get an AC ammeter and not a DC ammeter. Either an analogue or a digital ammeter will do the job. Some Ammeter has a dual mode which means it can support AC and DC at the same time (DC have a straight line symbol and AC have a wave symbol). As for the range of the scale, I used a 1 amp AC ammeter for Monitor and normal power supply repair. The reason for it was that for a 17" CRT Monitor, under normal working condition, it only consumes about .3 to .4 amp thus with 1 amp scale I could easily read the meter's scale. If I were to use a 5 or 10 ampere AC ammeter, guess I will have a hard time reading the exact scale value.



**Figure 17.2- A Dual Mode 5 Ampere Ammeter**

In another word, you have to get a suitable AC ammeter for your type of repair work. If you are repairing a big power supply and the normal consumption of current is 2 to 3 ampere, then I suggest that you get a 10 ampere AC ammeter. You can buy the AC ammeter from any of the electronic shops in your country.



**Figure 17.3- A One Ampere AC Ammeter**

Conclusion- With the help of this simple AC ammeter, you will for sure know if a part number can be used or not for substitution purposes. If the AC ammeter pointer has a constant reading even after the equipment runs for many hours, then you have found the right substitution part number. If the AC ammeter pointer slowly moves up to the right, then that substitution part number cannot be used and you have to try another part number.

**PART III**

**TRUE CASE  
Histories**

## **18) 11 True Case SMPS Repair Histories** **That You Should Not Miss**

I'm going to share with you some true case histories of how I have solved SMPS problem in Monitor and in Stand Alone type power supplies. For your information **I could not cover all kinds** of electronic equipment SMPS repair in this book alone and hope that by using the repair techniques from this true SMPS repair case histories, you could in some way **have an idea to tackle the type of SMPS you are repairing in your industry.**

### Case No 1: **No power**

A Samtron Monitor 4Bn sent for repair with the complaint of no power. All the components in the primary and secondary side checked to be good. For your information, sometimes a shorted component in the secondary side (components located **further downstream** the output voltage lines) could cause the power supply to stop working.

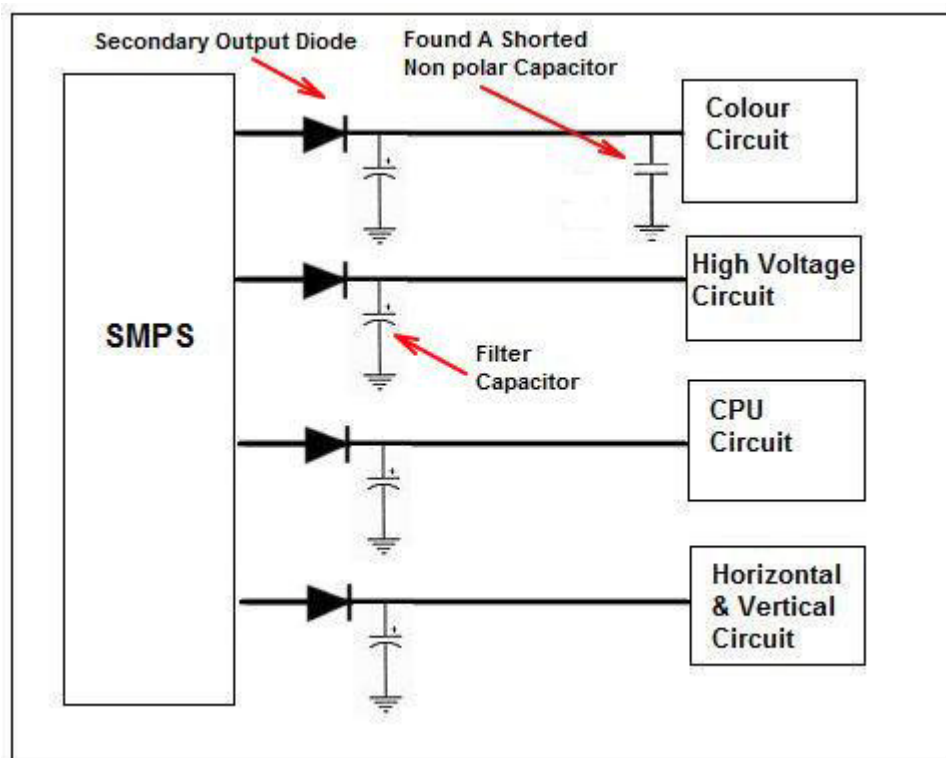
I began to use the resistance test (resistance test method in page 168) to find out if there are any components shorted along the output line. Do set your analogue meter to X1 ohm and place the red probe to cold ground and the black probe to all the cathode side of secondary output diodes. I managed to locate one line that has two readings (shorted reading).

Further tracing from this line, I managed to trace and find a shorted small resin ceramic capacitor located at the 80 volt line in the Monitor colour board. The capacitor shorted to ground and caused the power supply to stop operating. A new replacement of the small capacitor brought the power supply back to life again. Please refer to figure 18.1 and 18.2 in the next page.





**Figure 18.1- Shorted Non Polar Capacitor At CRT Board**



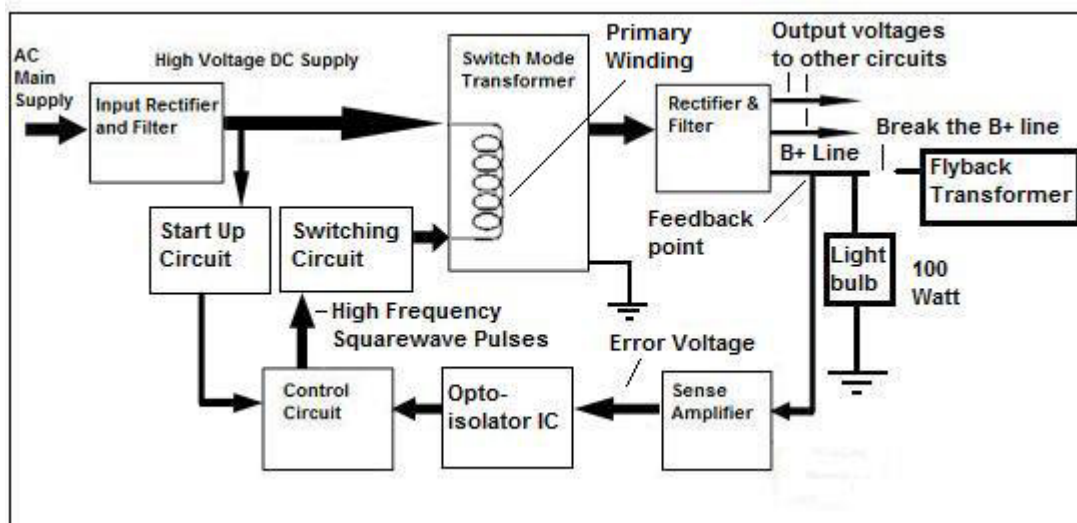
**Figure 18.2- The Location Of A Shorted Non Polar Capacitor**

**Note:** This is just an example of how I solve the no power symptom. Can you imagine that a non polar capacitor that was **located far from the Monitor SMPS still could affect the power supply?** It is your preference on which method you want to use. Some technicians may start by checking the fuse, then use voltage test to check on the AC supply and supply voltage to power IC and etc. In the above case, I have used the resistance test method first to check on the power supply.

### Case no 2: **No power and sometimes power blink**

This case is almost the same as case number 1, except that now I use the isolation method (chapter 14) to separate the SMPS and the high voltage section. Usually, the high voltage area draws the most current, thus by disconnecting the voltage path to the flyback transformer (flyback transformer draws lots of current) and therefore, I now know which section is giving me the problem.

Disconnect the B+ line as shown in figure 18.3 and connect a 100 watt light bulb between the B+ line and cold ground. I noticed that the bulb lights with good voltage measured at the B+ line and from this test I could conclude that it was the high voltage (Flyback Transformer) area that had caused the power supply to malfunction. Upon further inspection, I found that it was the flyback transformer primary winding that had shorted to secondary winding thus causing no power and sometimes power blink symptom in the power supply. A new flyback transformer cured the fault.



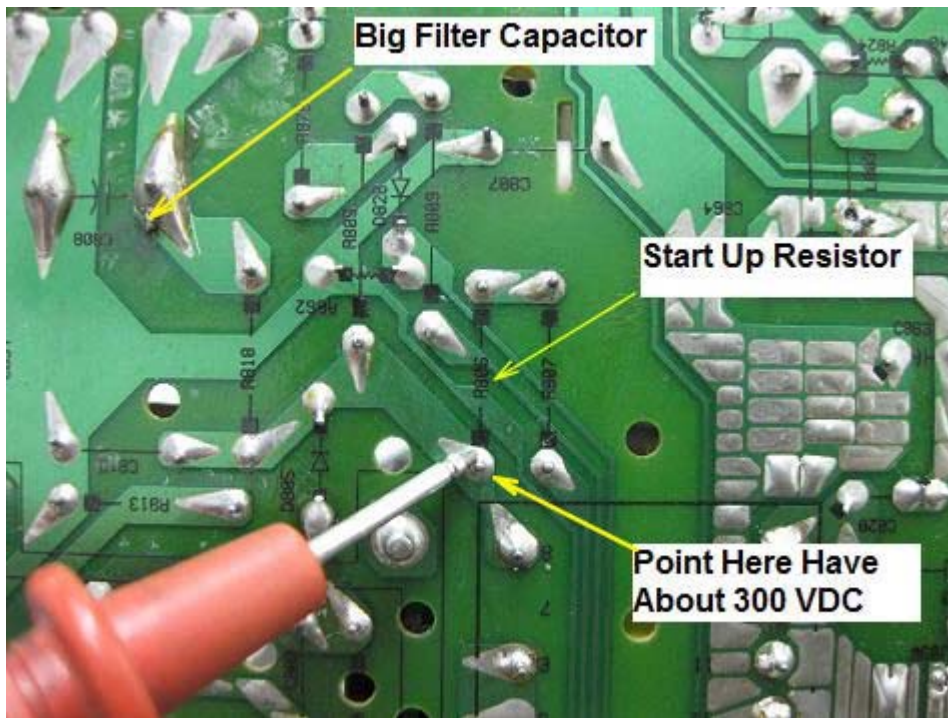
**Figure 18.3- The Right Place To Connect The 100 Watt Light Bulb**

**Note:** If you are troubleshooting and repairing a SMPS other than Monitor SMPS you can always use this method if you know which line that **draws the most current**. What you need to do is to get the SMPS schematic diagram and locate the output voltage line that draw the most current (usually high voltage circuit) and then connect a light bulb between the ground and the voltage line and power On. If the bulb remains off, suspect problem in the SMPS and if the bulb lights, this means the SMPS is good and the problem is on the other side of the circuit. **Always cut off the point after the feedback line as shown in figure 18.3.**

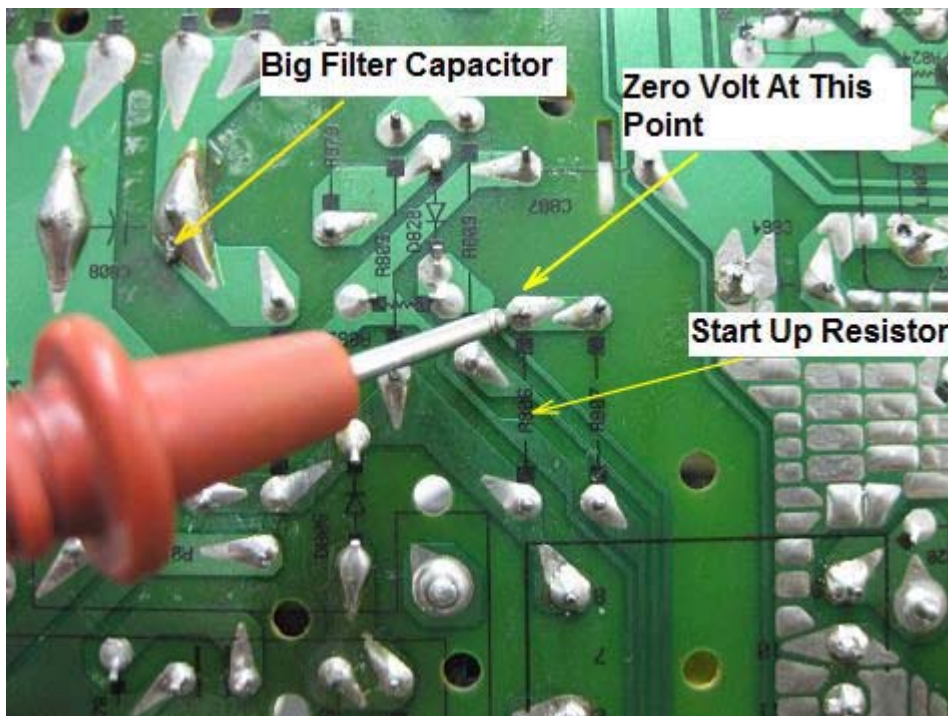
In order to be familiar with the type of SMPS you are repairing, I suggest that you take a good SMPS and perform the test first and see for yourself the result of connecting the light bulb. This can serve a lesson for you to efficiently tackle **your type** of SMPS even better in the future. Once you have understood your type of equipment/SMPS very well, chances of repairing the broken SMPS would be very high.

### Case no 3: **No power**

Fuse checked to be good and the next step would be to test the DC supply to the Power IC. By right the supply voltage to the PWM UC3842 IC should have about 16 volt (black probe to hot ground and red probe to pin 7) when power ON, but now reads zero volt indicating there might be a faulty component along the supply line. I started to trace backward from the VCC supply pin 7 and found that a start up resistor was open circuit. The value was 160k ohm and a new replacement brought back the life of the SMPS. Please refer to figure 18.4 and 18.5 in the next page.



**Figure 18.4 – Voltage Tracing At The Point Of Start Up Resistor**



**Figure 18.5 – Found Zero Volt After The Start Up Resistor**

**Note:** Some technicians would prefer to first trace from the positive pin of the big filter capacitor because they know that the 300 VDC from this line would pass through one or two start up resistors and thus lower down the voltage to about 16 VDC. This 16 volts DC would eventually go to

the supply pin of the PWM IC. Do not overlook that dry joints at the start up resistor area may cause no power symptom too.

Some shorted power IC may cause the supply voltage to drop to very low or even zero volt. Your next action is to **remove the power IC** and retest the SMPS. If the supply voltage was present, then this means the power IC has developed short circuit and pull down the supply voltage. You may have to check any corresponding component that relates to the power IC because if there is a shorted component around this area, it may also cause the supply voltage to become low or zero volt.

#### Case no 4: **No power**

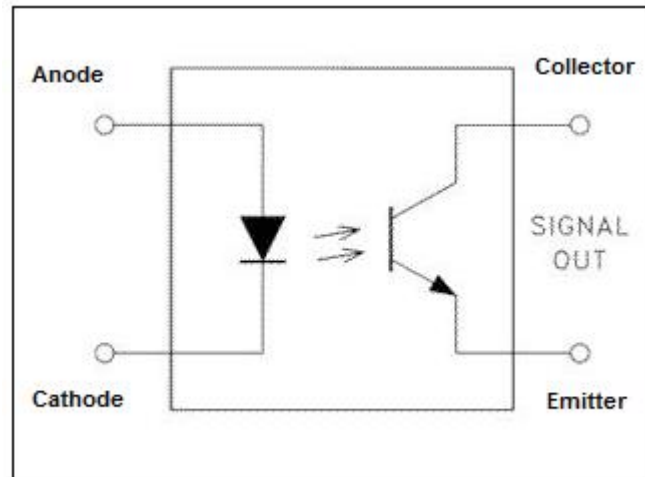
This is a LCD Monitor and I found the main fuse blown and this suggests that there might be some shorted components in the SMPS. Since I'm not familiar with this power supply circuit, what I did was to **check all** of the components in the primary and secondary side. I have spent about 15 minutes and found a 15 volt 1 watt zener diode shorted. Surprisingly the bridge rectifier was still in good condition. All secondary output diodes and the Optoisolator IC checked to be good. Since the zener diode was connected to the power IC, so I presumed the power IC had caused the fuse to blow together with the zener diode.

After the replacement of the three components, I did not turn ON the LCD Monitor immediately; in fact I connected a 100 watt light bulb across the fuse holder. Please refer to chapter 13 to see how I connect the light bulb. The bulb stays dim and then goes off. This suggests that there are no more short circuits in the SMPS. Next, I checked the output voltages with my digital multimeter by connecting the black probe to cold ground and the red probe to the cathode side of the secondary output diode. There seems to have **output voltages** and this indicates you can put in the new fuse and turn the set On again. The result is the power supply works perfectly fine.

**Note:** If you are not familiar with the type of SMPS you are checking, I suggest that you check all of the components in the primary section. Test also the primary winding of the switch mode transformer with Blue Ring Tester and check all secondary diodes with your analogue meter. If all components checked to be good then proceed to perform the resistance test by referring to case number 1.

For your information, the common fault for an Optoisolator IC is the short circuit between the collector and the emitter pin. You can test it by

using an analogue meter set to X 10 K ohm and it should not show two readings. If there were two readings then it was either considered shorted or leaky. The LED diode inside the Optoisolator IC rarely has problem and you can test it by using analogue meter set to X 1 Ohm and it should have only one reading.



**Figure 18.6- An Optoisolator IC**

If the Optoisolator IC has problem, it will cause many different types of symptoms like no power, low power or even power shutdown. Since this IC is not difficult to test, I suggest that if you come across power supply with the symptoms that I have mentioned above, you may need to test on the Optoisolator IC first. What about Optoisolator IC that breakdown when under load? Yes, I do come across Optoisolator IC that breaks down when under full operating voltage but it was rare. If you have tested all the components in the power supply section and still could not find out the fault, I guess there is no harm in replacing the Optoisolator IC and retest it. Who knows the power supply may come back to life again.

If you are weak in testing electronic components I suggest that you get the E-book on Testing Electronic Components.

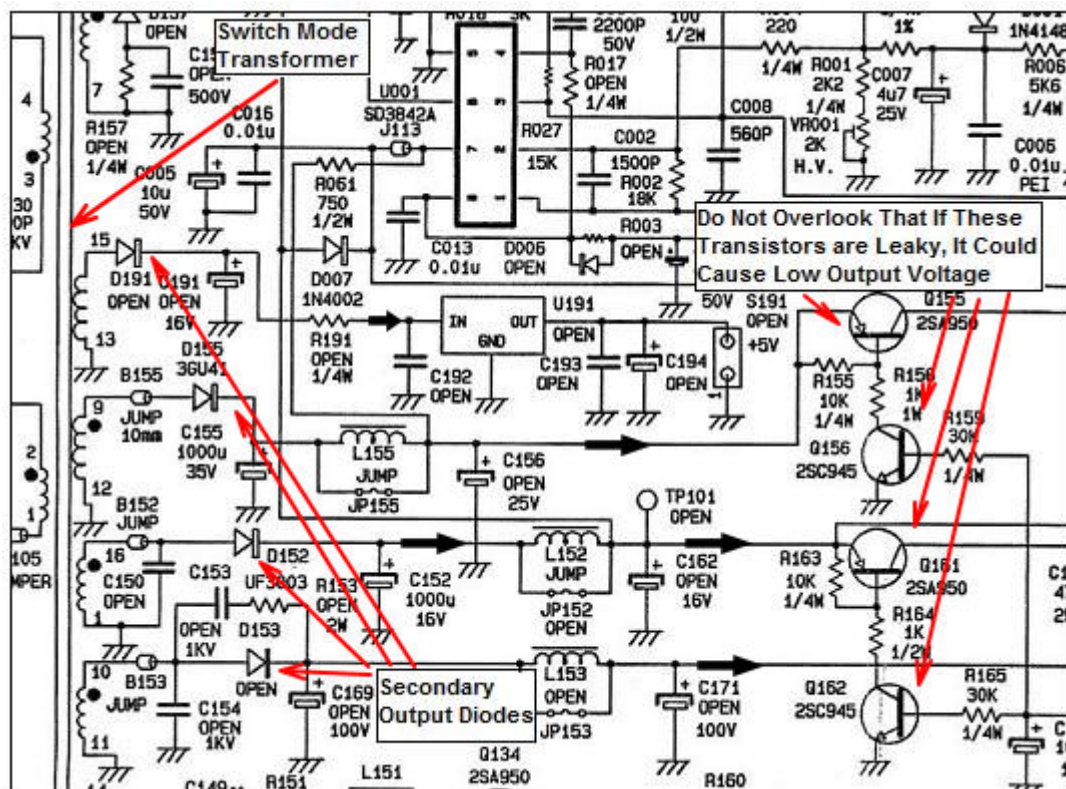
#### Case no 5: **Low output voltage**

The output voltages dropped more than half from the original voltage value. For example, 15 VDC became 7 VDC, 85 VDC became 35 VDC, 6.3 VDC became 2 VDC and so on. First, I thought it might be the high voltage area problem at the secondary side that had caused all the output voltages to become low but I was wrong because after using the isolation

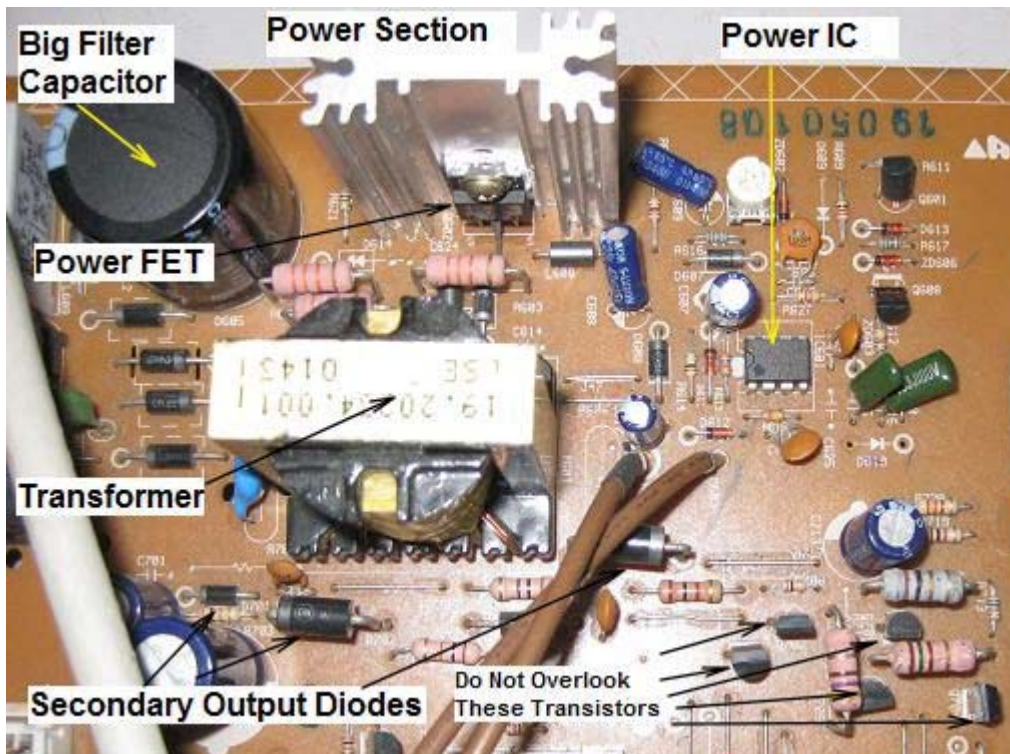
method (refer to chapter 14 and case number 2) the output voltages were still low.

I continued to check on all the components in the primary side thinking that there must be some faulty components that had caused this problem. 20 minutes was spent in checking the components in the primary and secondary side (secondary diodes), I found that all the components were tested good. The **resistance test method** also did not reveal any shorted components along all the output lines.

The only choice I have now was to remove the **first component** after every secondary output diode and test to see if it leaked or not. Please refer to figure 18.7 and 18.8. You would not believe this because I found a transistor that leaked between the collector and emitter pin. The transistor was replaced and all the output voltages came back to normal again.



**Figure 18.7- Bad Components In The Downstream Could Cause Low Output Voltage**



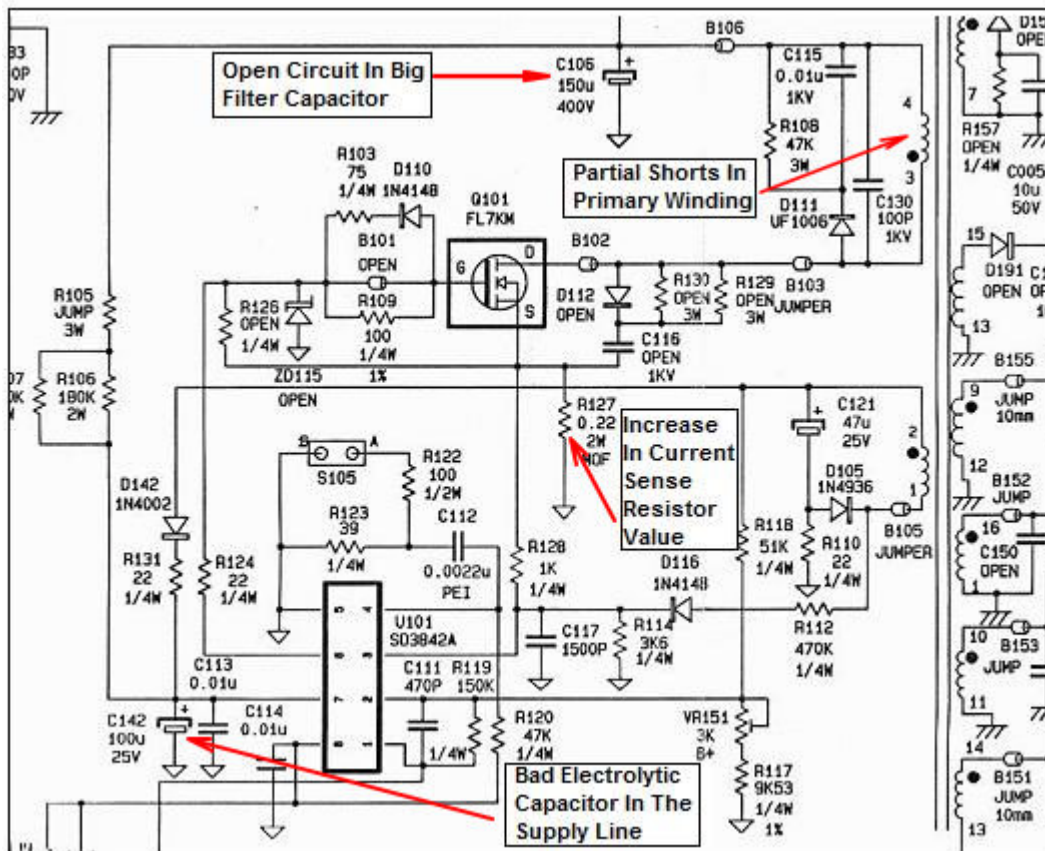
**Figure 18.8 - A Leaky Transistor At The Secondary Side Could Cause Low Output Voltage**

Note: It is important to check on the first component of every secondary output diode because a **tiny leakage in the secondary side components** could cause the primary section to malfunction and produced low output voltage. Below are just some of the possibilities that could cause low output voltage problem.

- 1) I have seen many times bad filter capacitors at the secondary side caused low output voltage.
- 2) A **partial shorted** primary winding in switch mode transformer also could cause output voltages to become low. For your information a severed or complete short circuit in the primary winding will usually blow the main fuse.
- 3) A bad electrolytic capacitor along the supply line to the VCC pin of power IC in the primary side can cause output voltages to become low.
- 4) Do not overlook that an open circuit in the primary side big filter capacitor could cause low output voltage too.



5) A higher than normal resistance value in the current sense resistor may also contribute to such problem.



**Figure 18.9- Some Possible Causes In SMPS Primary Side That Made The Output Voltages To Become Low**

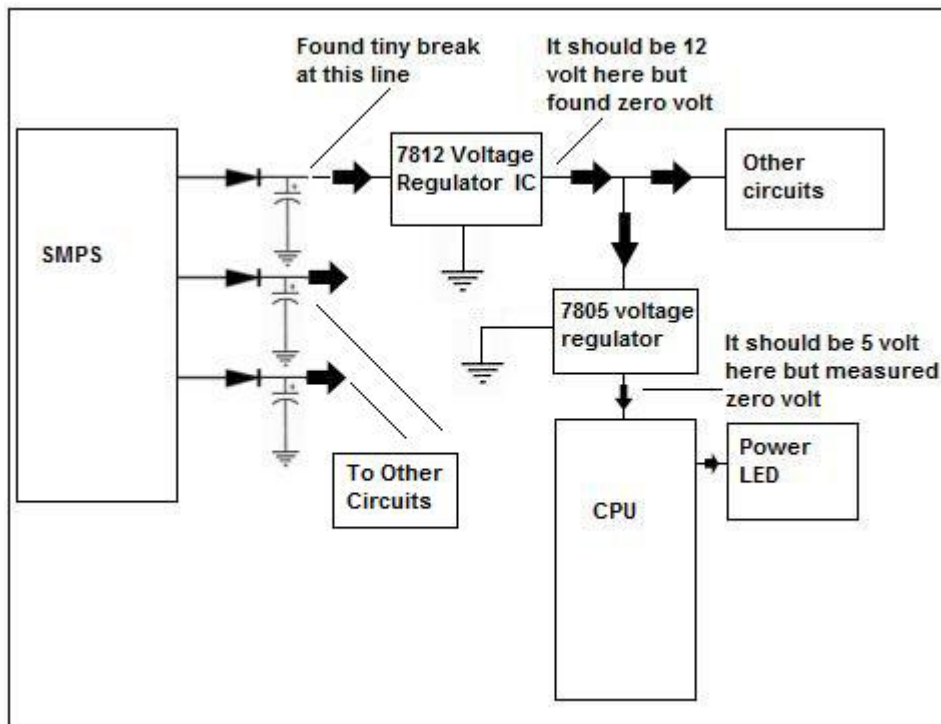
6) A shorted collector and emitter pin in the Optoisolator IC may cause the power supply to produce low output voltages too. Direct replace the TL431 IC (please refer to page 83 to see how TL431 IC look like) and retest it if all other components are found to be good.

7) There is also a possibility of wrong components used if the power supply had been repaired by some inexperienced technicians.

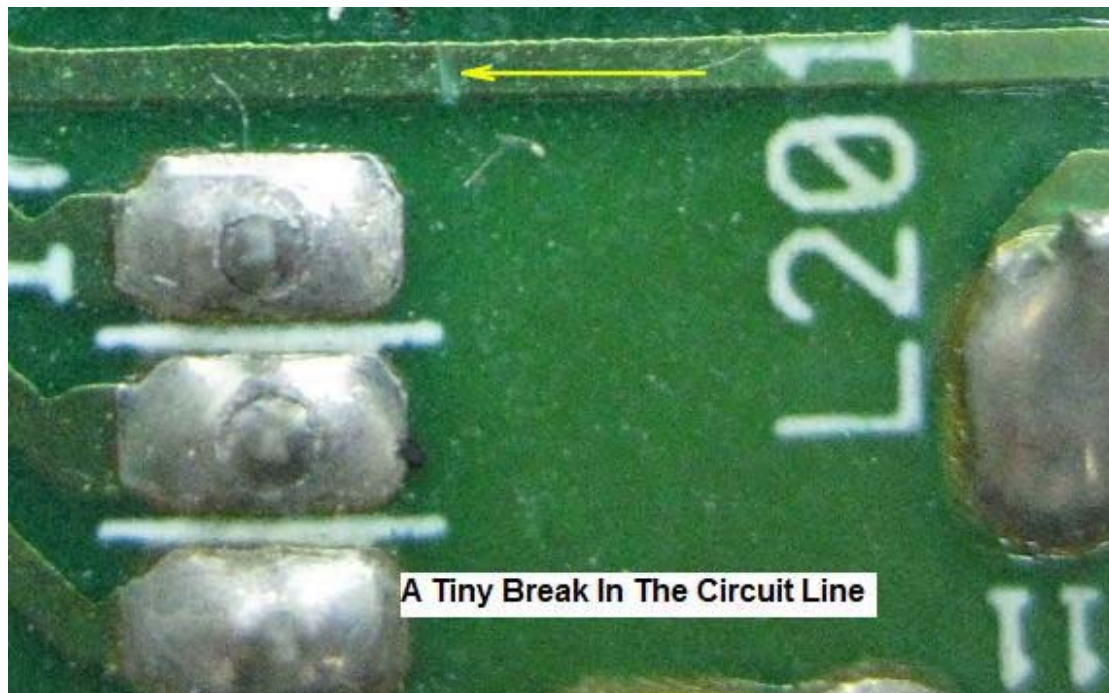
**Case no 6: No power**

The complaint for this Monitor was No power (no light in Power LED). After testing the secondary side output voltages, I found all the output voltages were good but why the power LED still did not light up? Since the power LED signal comes from the Monitor CPU, thus the CPU must first get a voltage (5 volt) from the power supply. I saw a 12 volt (7812) voltage regulator just located after the secondary output side. My

Voltmeter was used to check on pin 3 (output pin of 7812) and it read zero volt. This shouldn't be, as it had to be 12 volt. When I tested on pin 1 (input voltage pin), I noticed that there was zero volt! By right it should have about 15 volt. Since all the output voltages were good and there was no supply to the voltage regulator, I presumed that there must be an open resistor or dry joints in this area. Voltage test method was used to trace backward from the voltage regulator IC input pin and I found a tiny break along the line and this had prevented the output voltage of the SMPS to reach the 7812 voltage regulator IC.



**Figure 18.10- A Tiny Break In One Of The Secondary Output Line Could Cause The Power LED Light To Go Off**



**Figure 18.11- A Break In The Circuit Line**

**Note:** The 12 volt supply from the 7812 voltage regulator is needed to power up the horizontal/vertical oscillator IC, Color IC and most importantly to power up the CPU. The 12 volt entered 7805 (5 volt output) voltage regulator IC in order to provide 5 volt supply to the CPU IC.

From the above, we can conclude that although there are output voltages, this does not mean the equipment is in good condition. You have to make sure that all the output voltages reach **all the important electronic circuits** in the secondary side like CPU, color circuit, audio circuit, and high voltage circuit and etc unless you are working on a Stand Alone unit of power supply.

#### Case no 7: **No power**

The complaint was no power and for your information we can't directly replace the fuse and turn On the power because if we do that, then chances of the fuse being blown again due to some shorted components in the power supply. One should always practice using the series light bulb trick (please refer to chapter 13) in order to save your new fuse after replacement of components in the power side. In this case, the whole powers supply section was checked and did not find any shorted components until when the flyback/coil tester **tested on the primary winding** of the switch mode transformer. The LED light of the

flyback/coil tester went off the moment the probes touched the primary winding. The same result was shown by the meter even when tested on the transformer **off board**. This shows that the primary winding has developed a heavy short circuit. For your information, the meter should light up at least 4 LEDs when tested on a good switch mode transformer primary winding. A new replacement for the transformer and a main fuse restored the power supply.



**Figure 18.12- This Is The Right Way To Test SMPS Transformer Primary Winding**

**Note:** Make sure you discharge the big filter capacitor first before you work on the power supply. Always connect a light bulb across the fuse holder if you come across a blown fuse. This not only save the new fuse, it would also help to prevent the loud sound from the fuse that can scare you away just in case if there is still a short circuit in the power supply.

Here are some other causes that can blow the main fuse:

**Shorted bridge rectifier**-If one of the diodes in this bridge circuit shorted, the main fuse will surely blow.

**Shorted Posistor**- If you are repairing a CRT Monitor or Television, you will definitely see a square black box around the main supply section. If this posistor had shorted, it will take a way the fuse too. Posistor can't be test with multimeter, the best is to replace it with a working unit and retest the set.

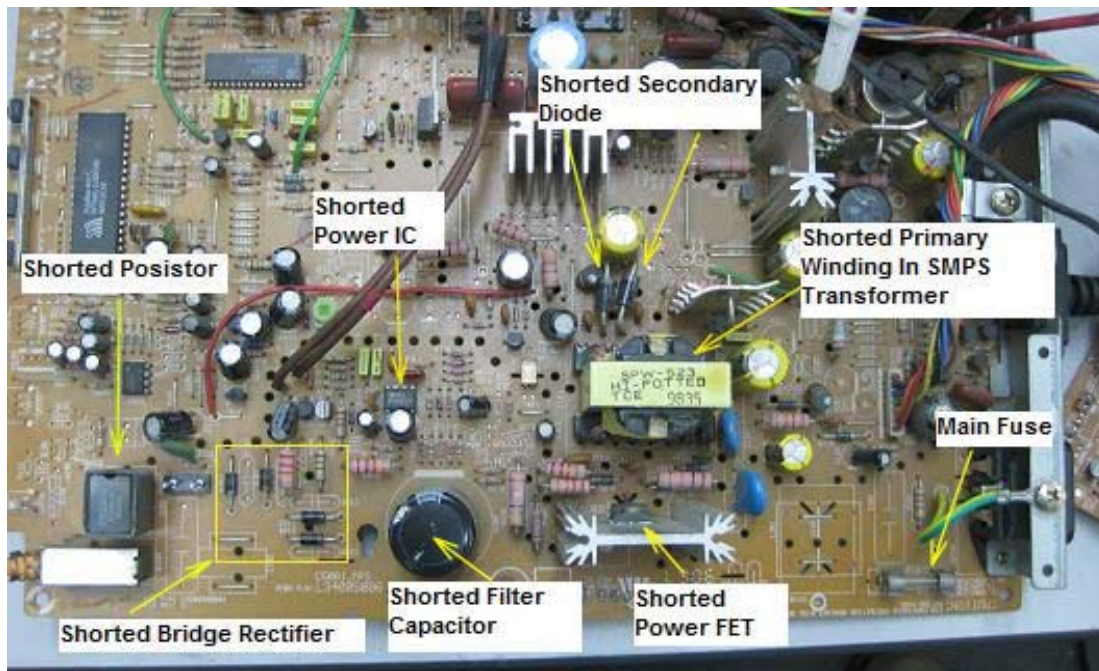
**Big filter capacitor breakdown when under full load**- This capacitor can be tested good when check with an ESR or a Digital Capacitance Meter but will fail when under full operating voltage. Sometimes it can go shorted and can be detected by an ohmmeter.

**Shorted Power FET**- A shorted power Mosfet (FET) will immediately blow the main fuse.

**Shorted power IC**- A shorted power IC will also blow the main fuse.

**Shorted primary winding of switch mode transformer**- as explained in case no 7

**Shorted secondary diode**- It can cause no power symptom and sometimes blow the main fuse too.



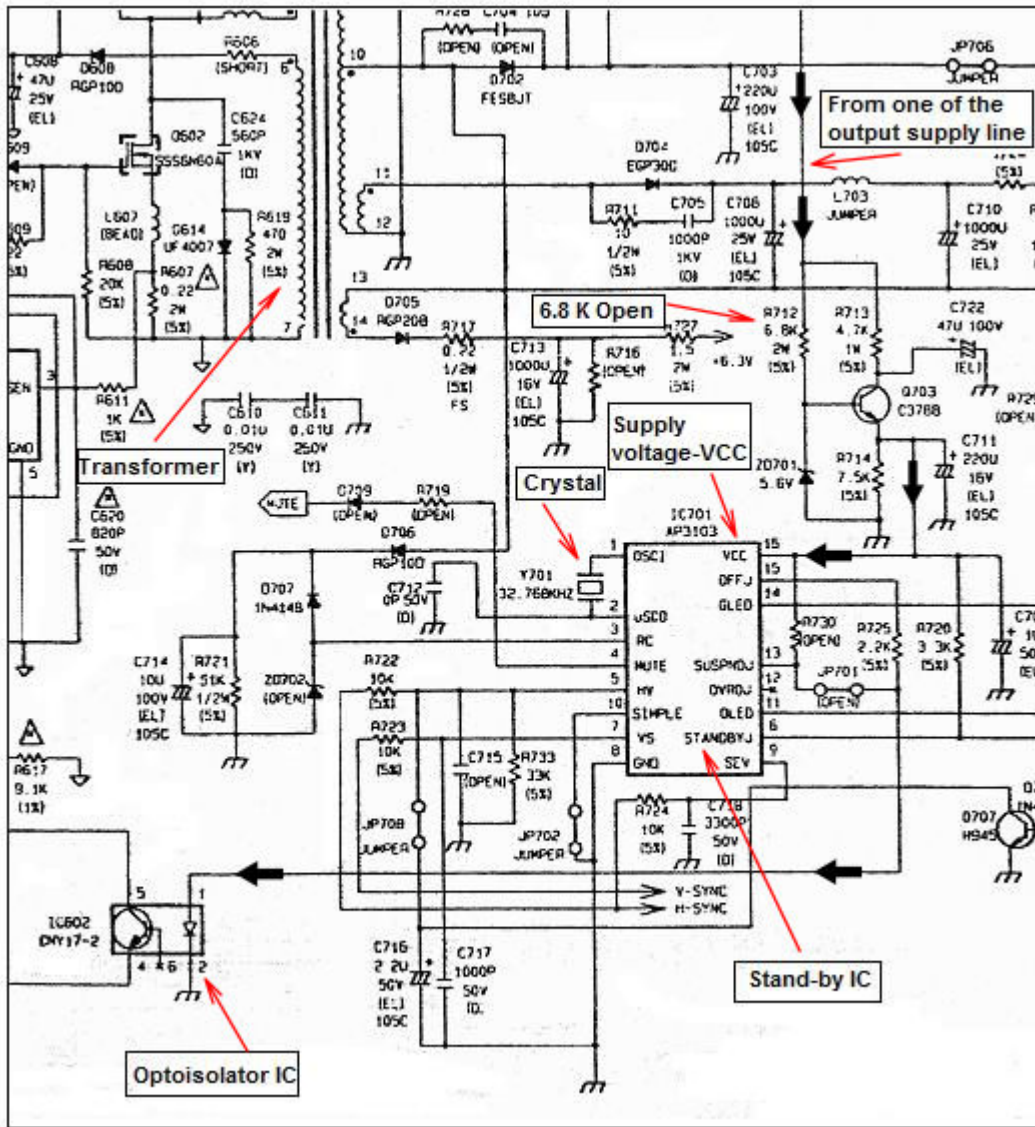
**Figure 18.13- Possible Shorted Components That Can Blow The Main Fuse**

By the way, I have seen many times the main power supply fuse was blown because of lizard inside it. Due to the short circuit caused by the lizard, the power FET and power IC were blown too.

#### Case no 8: **No Power**

There were output voltages but the voltages were a bit lower than usual and the power LED did not light. This power supply has an Optoisolator IC and I noticed that the signal to the anode side of the LED inside the Optoisolator IC was coming from the **Standby IC**. In some model, the signal comes from the CPU IC. This means that the Standby IC must first receive a 5 volt supply from the power supply so that it can send a good signal to the Optoisolator IC and control the On time of the switching frequency so that the power supply can produce the correct output.

When I checked on the supply voltage pin of the Standby IC, it read zero volts. This was the clue for me to continue to trace backward and see at where the voltage had missing. Eventually I found a resistor with the value of 6.8K (R712) Ohm had an open circuit prevented the 5 volt to reach the Standby IC. After replacing the resistor, the power supply output voltages came back to normal again. Please refer to figure 18.14 in the next page.



**Figure 18.14- An Open Resistor In Secondary Side Could Cause No Power Symptom**

**Note:** In some cases, the Monitor may power up for a moment and then shut down by itself. **Please take note of this.** If possible, in all SMPS, please check if the Optoisolator IC signal feedback is coming from a Standby IC or CPU or from one of the output voltage lines (generally B+ line) as understanding the feedback circuit will speed up your job in solving SMPS problem. **In many newer models, the Standby IC has already built into the CPU.**

If you are repairing a power supply that does not use Optoisolator IC as a feedback, that means if all the secondary output voltages have zero volts, then I can say that the **primary section has problem**. It could be the dry joints, circuit track broken, bad FET and power IC, leaky or shorted diode

and transistor, electrolytic capacitors that have high ESR or even an open circuit in resistor (start up resistor). If the power supply use an Optoisolator IC, then there are chances the secondary side components that **corresponding to the Optoisolator IC** may have problem. If you concentrate only on the primary section, I can say you may not find out the culprit. A shorted Optoisolator IC and TL431 IC could cause no power symptom (zero output voltage) and you may think that it was the primary section fault.

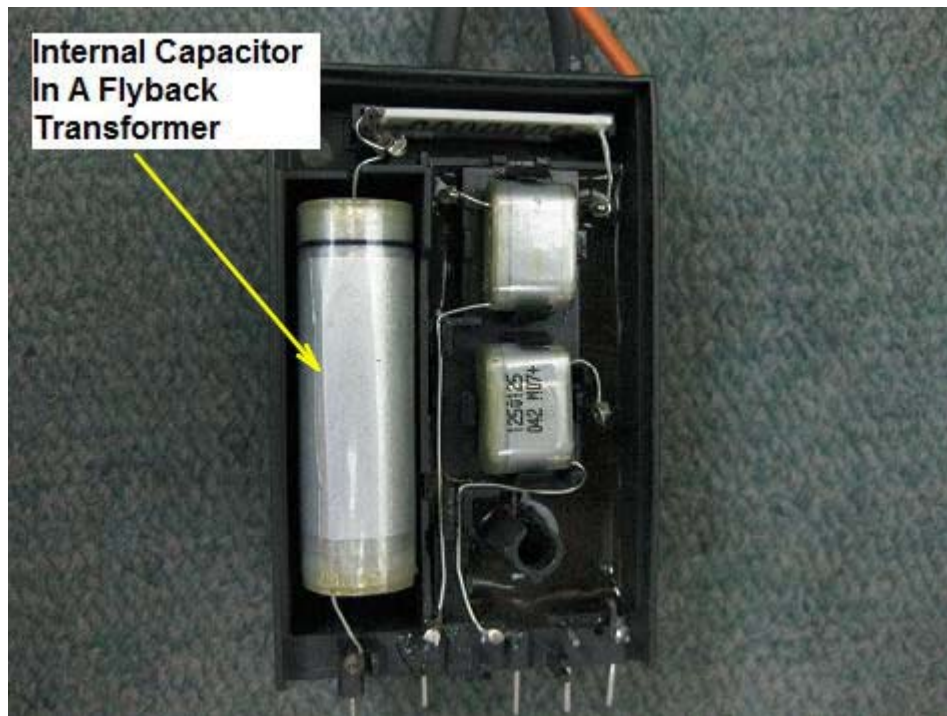
#### Case no 9: **Power off after turning On for a few seconds.**

Monitor Power LED turn off after few seconds was the complaint. This indicates that the power supply was trying to work but because there was a huge current draw (most probably shorted components in the secondary side) the power supply shut itself down. When you try power On the Monitor again, the same symptom happens again. You can place the red probe of your analogue meter to any of the cathode side of the secondary diode and the black probe to cold ground and you will notice that the pointer movement will kick up and **then back to infinity** the moment you turn On the Monitor.

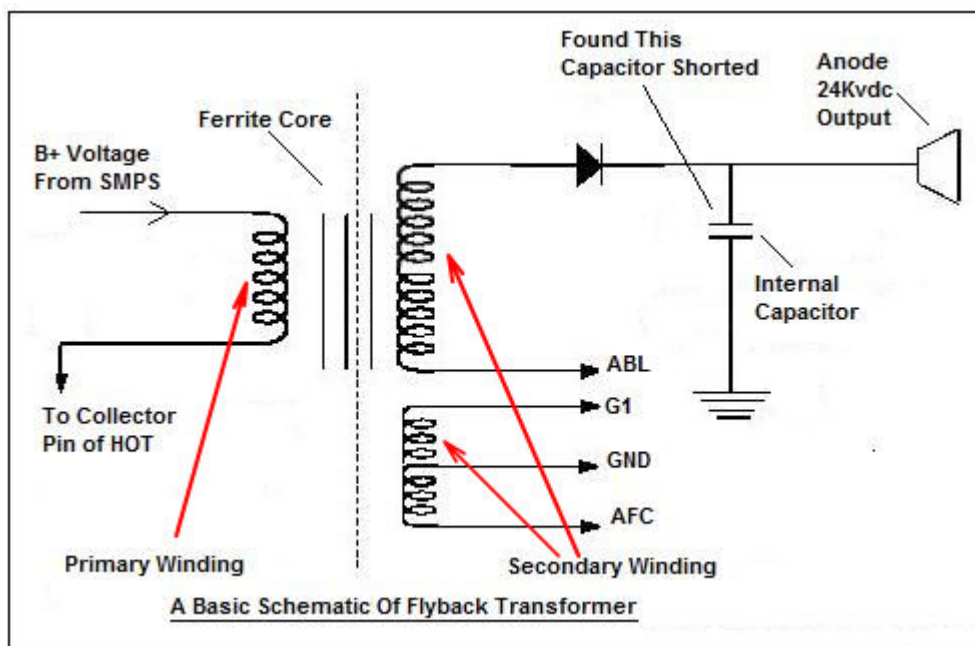
The best test to troubleshoot this problem is to isolate the power supply. Please refer to page 170 to read the isolation method.

First, remove the B+ coil and then connect a light bulb between the B+ line and cold ground and then power On. I saw the light bulb remains bright and the power LED is now ON without turning off. When I checked the output voltages of the SMPS it **showed good output voltages**. This test proved that there was a shorted component in the downstream circuit (high voltage area) that had caused the power supply to shutdown. Upon further inspection, I found that indeed the Flyback Transformer internal capacitor had shorted to ground. Please visit this website <http://www.electronicrepairguide.com/testing-flyback-transformer.html> on how I test a Flyback Transformer. A replacement brought the Monitor back to life again. Please see the photos in figure 18.15 and 18.16 in the next page.





**Figure 18.15- An Internal Capacitor Inside A Flyback Transformer**



**Figure 18.16- The Basic Schematic Diagram Of Flyback Transformer**

**Note:** If you repair a Stand Alone type of power supply then it is not necessary to check on the downstream circuit because when the power supply have good output voltages, **generally the power supply is working fine**. Besides the Flyback Transformer that was located in the downstream section, there are also a few components that need to be

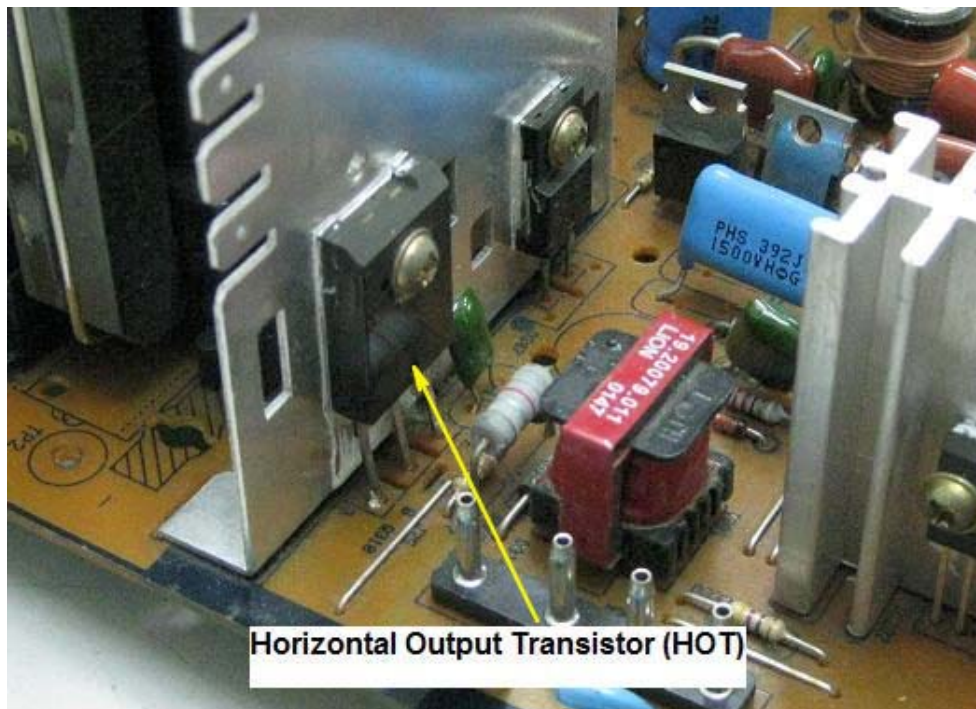
checked that could cause power supply to shutdown. Here are the possibilities:

- 1) It can be a shorted yoke coil (you have to test this with a Blue Ring Tester)



**Figure 18.17- A Shorted CRT Yoke Coil Could Cause Power To Shutdown**

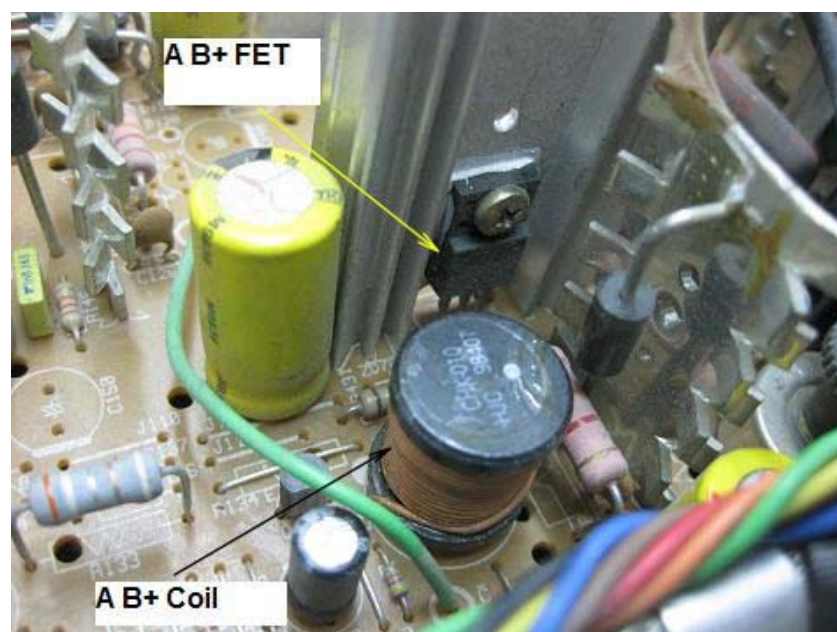
- 2) It can be a shorted horizontal output transistor (HOT)



**Figure 18.18- A Horizontal Output Transistor (HOT) In CRT Monitor**

3) It can be a shorted B+ FET and B+ Coil

4) It can also be bad components located in the feedback area-please refer to case no 7 or 8



**Figure 18.19- A B+ FET and A B+ Coil In A CRT Monitor**

There was a case of a Monitor when turned On, the power LED lights On for few seconds and then Off. Careful checking at the secondary side, found there was an open pico fuse along the B+ line that had prevented the B+ voltage reaching the flyback transformer thus no high voltage was generated. Due to this, the CPU did not get a feedback signal from the flyback transformer thus the CPU sent a signal to the Optoisolator IC causing the power IC in the primary side to stop producing waveform to the power FET. Without switching waveform from the Power IC, the switch mode transformer would not work and no output voltage produced and the power would be Off. **It all happens in a split second.**

**No matter what type of power supplies you are repairing, the downstream components play an important part** because when there are components shorted at the downstream, it can cause the power supply to shutdown.

#### Case no 10: **Higher than normal output voltage**

The output voltage was higher than the normal in this NEC Monitor and it caused the Monitor high voltage to shutdown in a few seconds after the set was turned on. I used the isolation method (please refer to chapter 14) and the light bulb was very bright and the voltage measured at the B+ line was more than 190 volt DC and the rated filter capacitor along the B+ line was 220uf 200 volt. The voltage was abnormal and **it should be in the range from 120 to 150 VDC**. Not only the B+ line voltage increased, all other output voltages were increase too.

The question is, why all the output voltages increased? The answer is in the **feedback circuit** because if no signal coming from the B+ line send back to the primary side (power IC) through the Optoisolator IC then the waveform produced by the power IC to the power FET was not normal. This will cause the switching time to the switch mode transformer becoming longer, thus the output voltage produced will be increased. I found along the feedback line there was a high ohm resistor open circuited. A replacement of only a resistor made all the output voltages back to normal again.

**Note:** The Monitor high voltage shutdown was due to the excessive voltage produced by the flyback transformer (because the B+ voltage already increased to more than 190VDC) triggers the X-ray protection circuit in the horizontal oscillator IC thus shutting down the horizontal driver signal to the horizontal output transistor (HOT). Without the

horizontal driver signal to the base of the HOT, the flyback transformer would not be energized and the high voltage would collapse.

### Case no 11: **Power Blink**

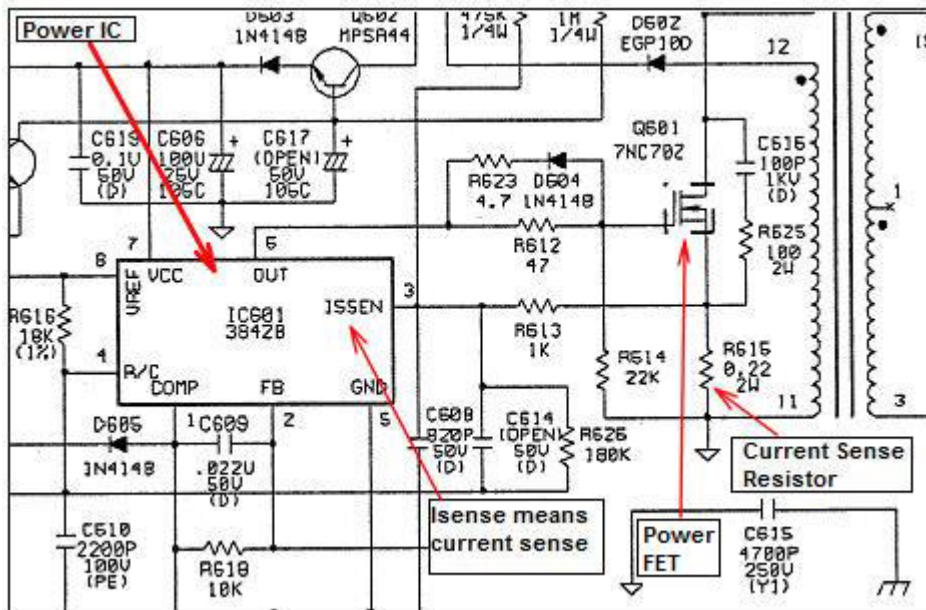
The complaint was power blink and the output voltages from the SMPS fluctuated. In order to find out which section has problems, we must use the isolation method to isolate the problem (please refer to chapter 14). After the B+ coil was removed and the light bulb was connected and power On, the light bulb still blinked and this suggested that it was not the downstream components that had caused the power to blink. **The problem was in the SMPS section.**

Since I already know about the problematic section after using the isolation method, my whole concentration was on the power supply area. In the power side, I found a resistor located along the feedback line to the Optoisolator IC value had changed from 68 K Ohm to about 100 K Ohm.

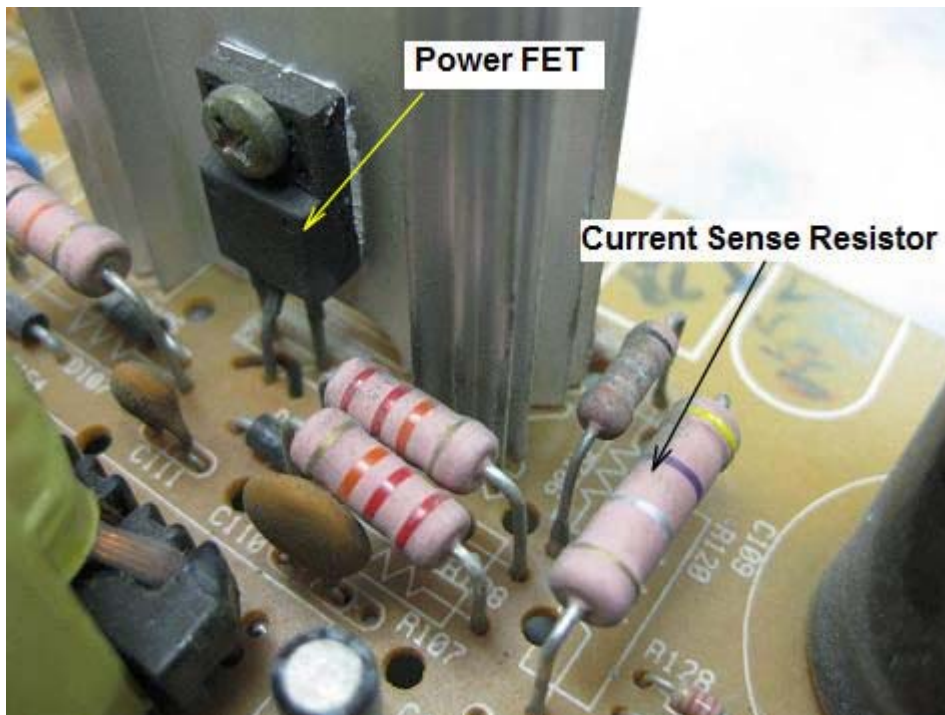
**Note:** There are many sections in the power supply that could cause the power to blink and below are a few more true cases of power blink problem.

1) Sometimes another problem could occur after solving the primary problem. For example, a SMPS came in with **no power symptom** and you had checked and replaced the common components like Fuse, Power IC, Power FET and etc and thinking that you have solved the problem but when you power On the SMPS, another problem occurred could be the **power blink** or **low output voltage**. If this happened, then you have to put more concentration on checking the passive components like the resistors and capacitors.

There was a case of no power symptom and after replacing the common components, the power started to blink. Upon further inspection, I found the current sense resistor value increased from 0.33 ohm to 1.2 ohm. I would suggest that if you come across a SMPS with no power symptom and the fuse was tested good, then start to **check on all the components** in the power supply instead of just concentrating only on the semiconductor components like the power IC, power FET, bipolar transistors and diodes.



**Figure 18.20- A Bad Current Sense Resistor Could Cause Power To Blink**



**Figure 18.21- A Typical Power FET And Current Sense Resistor In SMPS**

2) If you use a different type of Power IC, for instance, replacing the UC3842A IC with KA3842A, it may cause the power supply to blink. In some SMPS designs, they can only support the **same type of part**

**number**, as any other equivalent part number would only cause more problems.



**Figure 18.22- A KA3842A PWM IC**



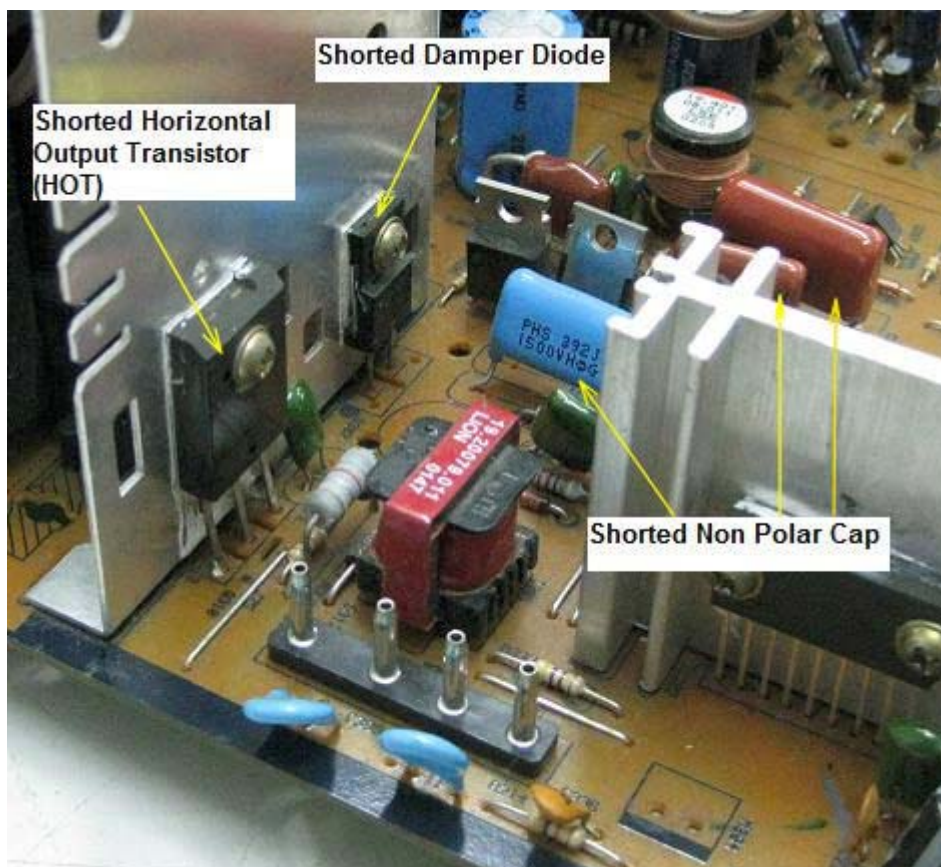
**Figure 18.23- UC3842A PWM IC**

3) Do not overlook the fact that **component breakdown when under full load** could also cause power to blink. I came across quite a number of power supplies with power blink problem caused by diode that breakdown when under load. Normally, if I could not detect any bad

components in the power supply, I would **direct replace semiconductor components one by one** and retest the set.

Usually, it was a diode in the RUN DC circuit (please refer to page 29) that had caused the power to blink. This diode supply DC voltage to the power IC and if it breaks down intermittently, it will affect the overall performance of the switch mode transformer. If the switching transformer was affected, then the output dc voltage would be affected as well. This will cause a wrong signal to be sent to the feedback circuit and cause the power to blink.

4) Many times, a shorted component like Horizontal output transistor (HOT), shorted yoke coil, shorted damper diode, shorted non polar capacitor or other semiconductors **along all the output lines** in the downstream circuit could also cause power to blink. You have to use the resistance test method (please refer to page 168) to check it out.



**Figure 18.24- Shorted Components In The Downstream Circuit Could Cause Power To Blink Too**



Conclusion- In SMPS repair, we as electronic repairers, must know how to distinguish as to which section is faulty. Spending and concentrating your whole time to **check on a working section** is just a waste of time. You should only concentrate on the problematic section so that you could locate the fault fast and make the equipment work again.

Do please study carefully on how I have solved all the power supplies problems in the true case histories and apply the techniques that I have used. Every repair technicians have **their own ways or procedures** to tackle SMPS fault. Some prefer to use scope, some use voltage testing while others will start to check on the components first. It is **totally up to you** which way you want to use. Once you have discovered the standard procedure of troubleshooting power supplies, I believe there will be no power supplies that you cannot deal with.

Understanding how a power supply work is one of the keys to successful power supply repair. Practice more on different types of power supplies repair will make you become better in solving **any type** of power supplies problems. In other words, if you want to become a professional in SMPS repair, then you have to repair more power supplies.

Part IV

**Troubleshooting  
and Repairing ATX  
Power Supply**

# 19) Troubleshooting and Repairing Computer ATX Power Supplies

## Introduction

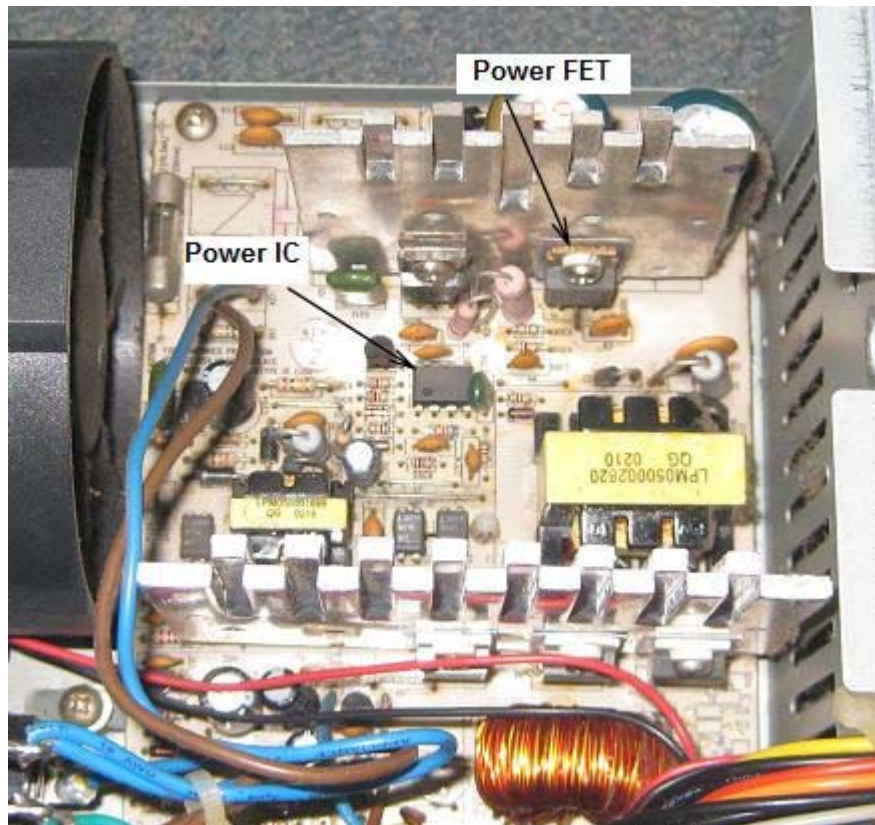
Computer power supply unit or PSU is the device that converts the input AC voltage to the DC voltage needed by the personal computer. ATX stands for Advanced Technology Extended. Not like the old AT PSU, an ATX power supply does not directly connect to the computer system power button, it allows the computer to be turned off via software. However, many ATX power supplies have a manual switch on the back to make sure that the computer is truly off and no power is being sent to the components. If this switch is on, energy will flow to the components even when the computer appears to be "off" unless you press the on button. This is known as soft-off or standby.

Since the introduction of IBM PC/XT there has been about a dozen different Power Supplies types in the market such as AT, Baby AT, ATX, BTX, LPX, SFX, EPS, WTX, EBX, TFX, LFX, CFX. They differ by their structure, size, form factors, volt/amp ratings and connectors. While they may look different on the outside, most PC power supplies use the same electronics on the inside and it's not difficult to fix them. In this chapter I'm going to explain only about the ATX power supplies since they are most commonly in used today.

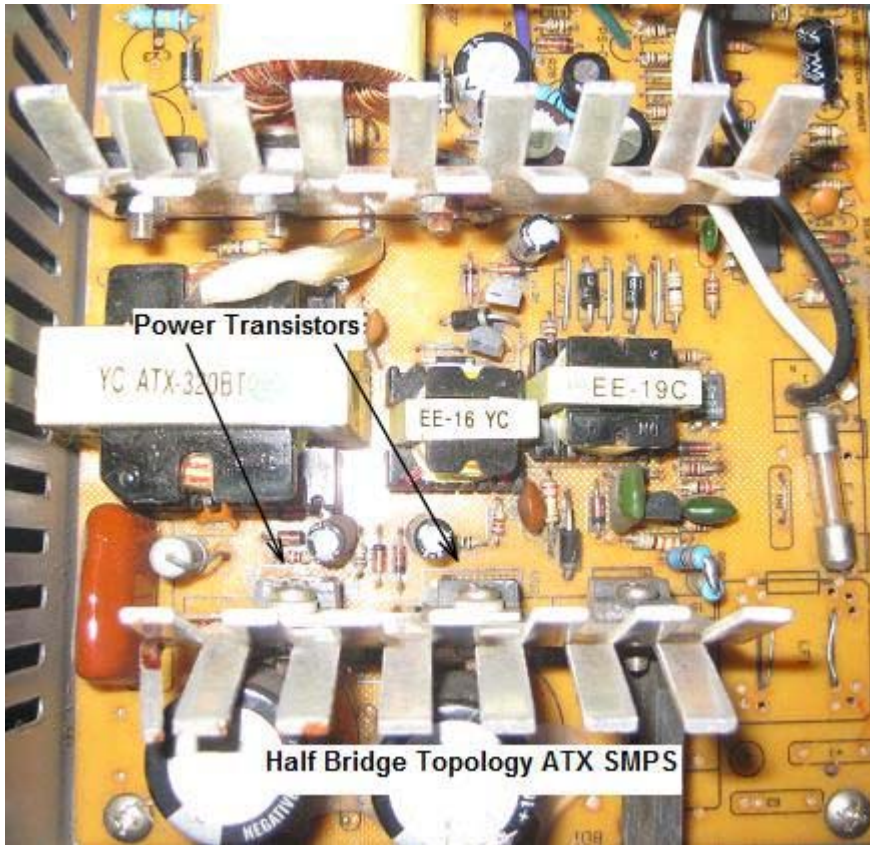
Having a higher wattage power supply than the required capacity is always desirable, as you can add new devices like hard drives, CD/DVD drives, tape drives, ventilation fans, etc to the computer without worrying about whether the power supply can provide enough power.

If your requirement is 300 watt, then fit your computer with a 350 watt power supply. Additional wattage does not mean that your electricity bill will be higher. It just gives you an option to add additional devices to your computer and also there will be lesser load on the power supply. A 350 watt power supply will consume only 200 watt of power if the devices connected to it consume 200 watt of work. By using a PSU that delivers more power than required, it means **it won't be running at full capacity**; which can prolong life by reducing heat damage to the PSU's internal components during long periods of use. **Always replace a power supply with an equivalent or superior power output (Wattage).**

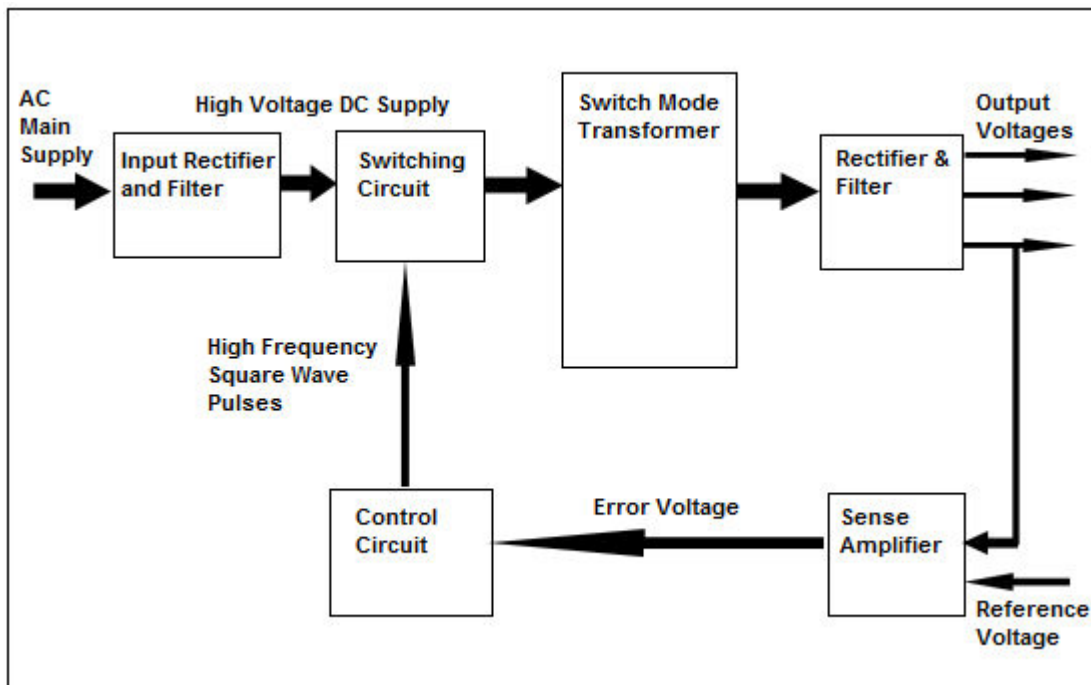
Generally ATX power supply can be broken down into two types. The first type would be the one that use the **Mosfet technology** (figure 19.1) with Power IC and Power FET to drive the transformer. The second type would be the one that use the **Half bridge topology** (figure 19.2) where a pair of transistors was used to switch the high voltage supplies across the primary winding of the SMPS transformer. I would only explain the second type as the first type explanation could be found in chapter 3.



**Figure 19.1- ATX SMPS That Use The Power FET And Power IC**



**Figure 19.2- A Half Bridge Topology ATX SMPS**



**Figure 19.3- Block Diagram Of A Half Bridge Topology SMPS**

## How The Half Bridge Topology SMPS Works

The main AC supply first enters a rectifier/filter circuit, which converts the AC main supply into a very high value DC voltage and filter it. This high voltage DC supply is then given to a switching transistor circuit. The switching transistors are switched on and off at a very high speed by a control circuit which produces very high frequency square wave pulses.

The switching transistors switches the given high voltage DC, on and off at the same high frequency and gives square wave pulses as the output. These square wave pulses are then given to the primary winding of Switch Mode Transformer. These pulses induce a voltage at the primary winding of the transformer which will generate voltages at the secondary windings.

The voltages at the secondary winding is then rectified and filtered to produce the required output. In order to regulate the output, one of the generated output voltages is sent back to the switching section. This voltage is first sent to a sense amplifier circuit which compares it with a reference voltage and generates an error voltage. This error voltage is then given to the control circuit which controls the switching transistors to regulate the output voltage.

The function of the error voltage is such that if there is an increase in the output voltage, the error voltage will **reduce** the “On” time of the switching transistors, which reduces the output voltages. When there is a drop in the output voltage, the error voltage **increases** the “On” time of the switching transistors, which increases the output voltage.

By controlling the “On” time, this would make the output stable in both the high or low output conditions. Other than this basic operation, most of the SMPS has the capabilities to protect itself from overload and short circuit in the output section.

## ATX Power Supply Connector Pinouts And Signals

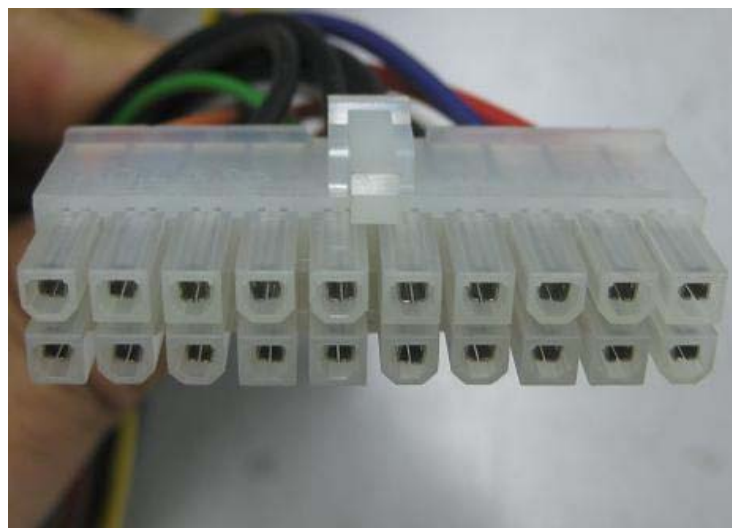
Generally there are two types of ATX power supplies currently in the market and with different type of connectors.

- 1) **ATX version 1 Power Supply**
- 2) **ATX version 2 Power Supply**

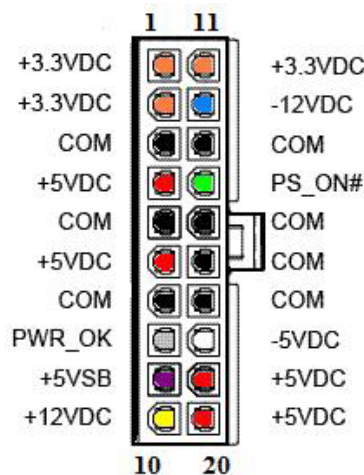
Having an understanding of both types of ATX power supplies connector pinouts and signals could help you to turn “On” the power supply and also what voltage to expect from the output for testing and repairing purposes.

For your information, obviously there are **more latest PC power supplies cables and connectors coming out to the market every now and then** but I fell that if you understand these two types of ATX cables and connectors, you would be able to perform the testing too in newer type of power supplies that have newer type of cable and connector configuration.

**Pin out configuration of ATX version 1 Power Supply**



**Figure 19.4- An ATX Version 1 Connector**



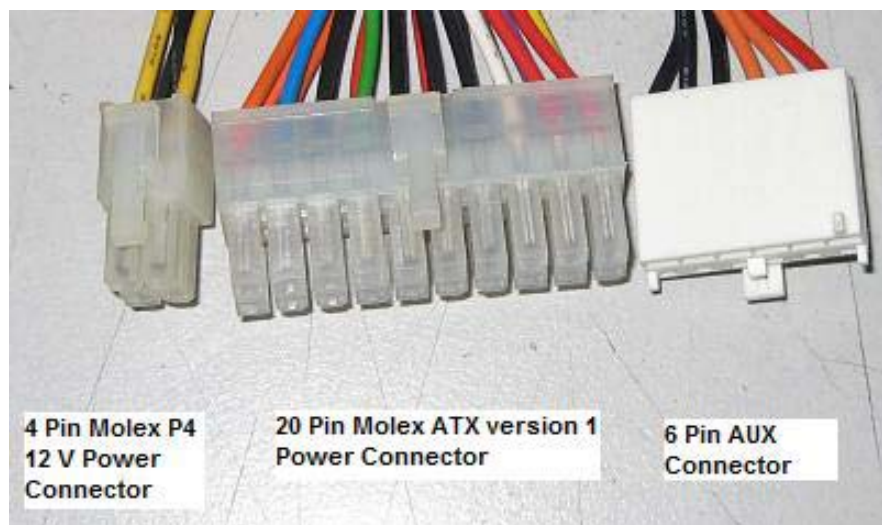
**Figure 19.5- 20 pin Molex ATX Version 1 Power Supply Connector**

Pin	Signal	Wire Color	Description
1	3.3V	Orange	+3.3 VDC
2	3.3V	Orange	+3.3 VDC
3	COM	Black	Ground
4	5V	Red	+5 VDC
5	COM	Black	Ground
6	5V	Red	+5 VDC
7	COM	Black	Ground
8	PWR_OK	Gray	Power OK is a status signal generated by the power supply to notify the computer that the DC operating voltages are within the ranges required for proper computer operation (+5 VDC when power is OK)
9	5VSB	Purple	+5 V Standby Voltage
10	12V	Yellow	+12 VDC
11	3.3V	Orange	+3.3 VDC (Brown is +3.3 VDC Sense)
12	-12V	Blue	-12 VDC
13	COM	Black	Ground
14	PS_ON	Green	Power Supply On (Active Low). Short this Green wire to ground to switch power supply On. Disconnect from ground to switch off
15	COM	Black	Ground
16	COM	Black	Ground
17	COM	Black	Ground
18	-5V	White	-5 VDC
19	5V	Red	+5 VDC
20	5V	Red	+5 VDC

**Figure 19.6- ATX Version 1 Power Supply Pin-outs**



Some ATX version 1 power supplies have extra connectors as seen in the photo below

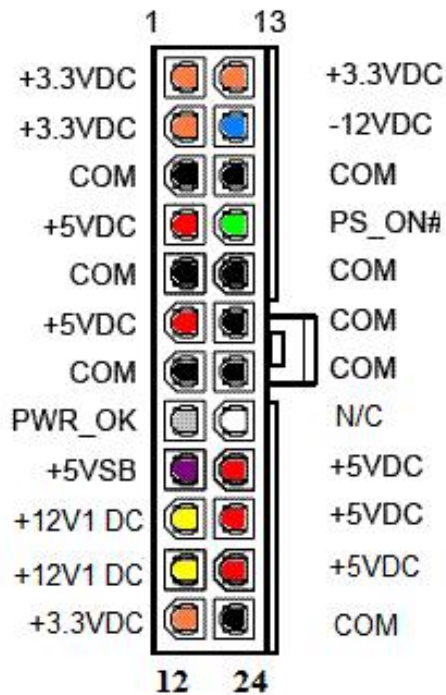


**Figure 19.7- Types Of Connectors**

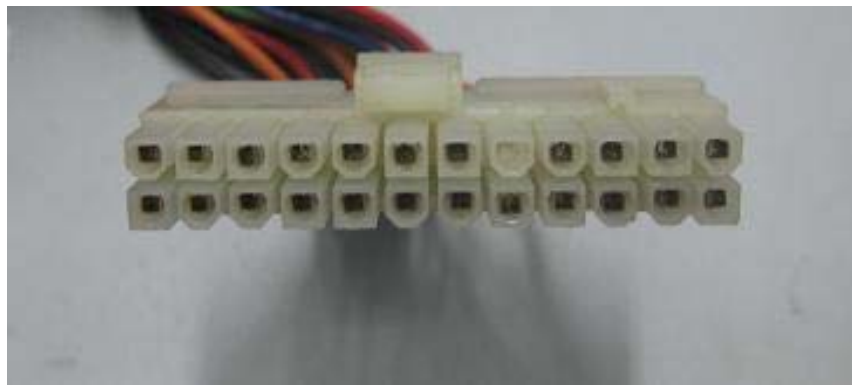
The 4 Pin Molex P4 12V Power Connector is use specifically for Pentium 4 Processor Motherboards while the 6 Pin AUX power connector was added to provide extra wattage to motherboards for 3.3 and 5 volts. This connector is rarely used anymore. It's most commonly found on older dual CPU AMD motherboards.

### **Pin out configuration of ATX version 2 Power Supply**

Changes to ATX standard were made to support 75 watt PCI Express cards requirements. New ATX version 2 uses new connector with an extra +3.3 V, +5 V, +12V and ground. Most motherboards nowadays allow using an old ATX version 1 power supply with 20 pins connector that can fits in a 24 pin socket.



**Figure 19.8- 24 pin Molex ATX Version 2 Power Supply Connector**



**Figure 19.9- An ATX Version 2 Power Supply Connector**

Pin	Signal	Wire Color	Description
1	3.3V	Orange	+3.3 VDC
2	3.3V	Orange	+3.3 VDC
3	COM	Black	Ground
4	5V	Red	+5 VDC
5	COM	Black	Ground
6	5V	Red	+5 VDC
7	COM	Black	Ground
8	PWR_OK	Gray	Power OK is a status signal generated by the power supply to notify the computer

			that the DC operating voltages are within the ranges required for proper computer operation (+5 VDC when power is OK)
9	5VSB	Purple	+5 V Standby Voltage
10	12V	Yellow	+12 VDC
11	12V	Yellow	+12VDC
12	3.3V	Orange	+3.3VDC
13	3.3V	Orange	+3.3VDC
14	-12V	Blue	-12VDC
15	COM	Black	Ground
16	PS_ON	Green	Power Supply On (Active Low). Short this Green wire to ground to switch power supply On. Disconnect from ground to switch off
17	COM	Black	Ground
18	COM	Black	Ground
19	COM	Black	Ground
20	-5V	White	-5 VDC
21	5V	Red	+5VDC
22	5V	Red	+5VDC
23	5V	Red	+5VDC
24	COM	Black	Ground

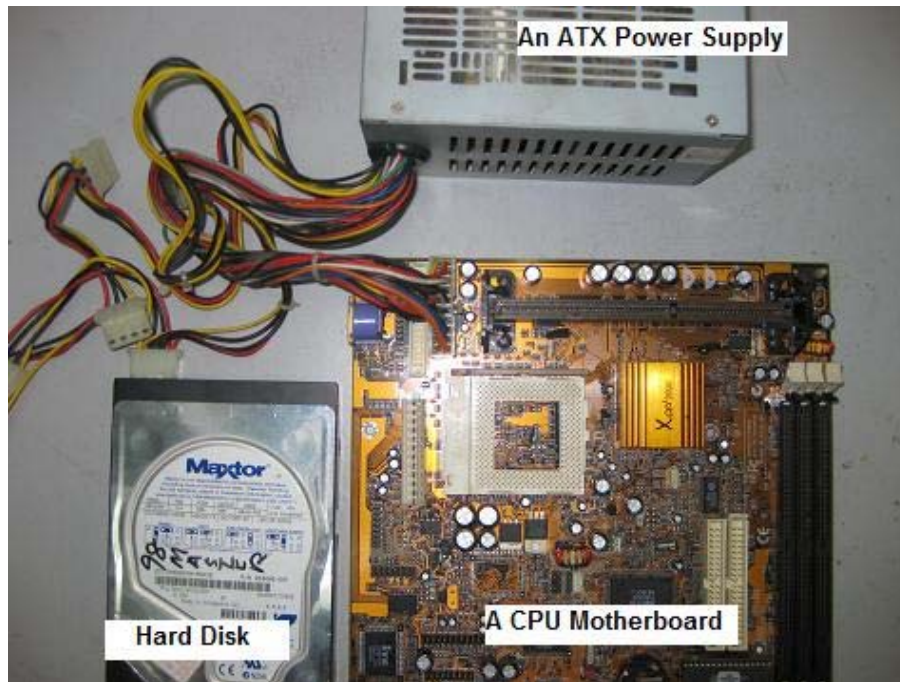
**Figure 19.10- ATX Version 2 Power Supply Pin-outs**

**Note:** There is a curiosity in the new version of the ATX version 2 Pinouts specification. It is about the pin 20 (-5 volt) connection because in certain specification this pin is no longer in used and marked as NC (Not connected). However, according to the manuals of certain motherboards with a new 24 pin connector, the -5 volt is still present. Due to this, you must keep in mind that when you want to test a power supply with a 24 pin connector, the -5 volt output **may or may not exist**. The -5 volt should always be present on a 20 pin connector.

The PWR\_OK output (pin 8) of ATX version 1 and 2, also called PWR\_GOOD or PWR\_ON, is used by the power supply to show that the most important outputs (+12 V, +5 V and +3.3 V) are within their limits and can supply a nominal current.

## Troubleshooting and Repairing ATX SMPS

When it comes to troubleshooting and repairing any kind of ATX power supplies, the most important thing that you need to do is to make sure that the power supply is connected to a sufficient load like to a motherboard and hard disk (you can buy cheap and used motherboard and hard disk from any local computer shop) as seen from figure 19.11.



**Fig 19.11- Connect The ATX Power Supply To A Motherboard And A Harddisk**

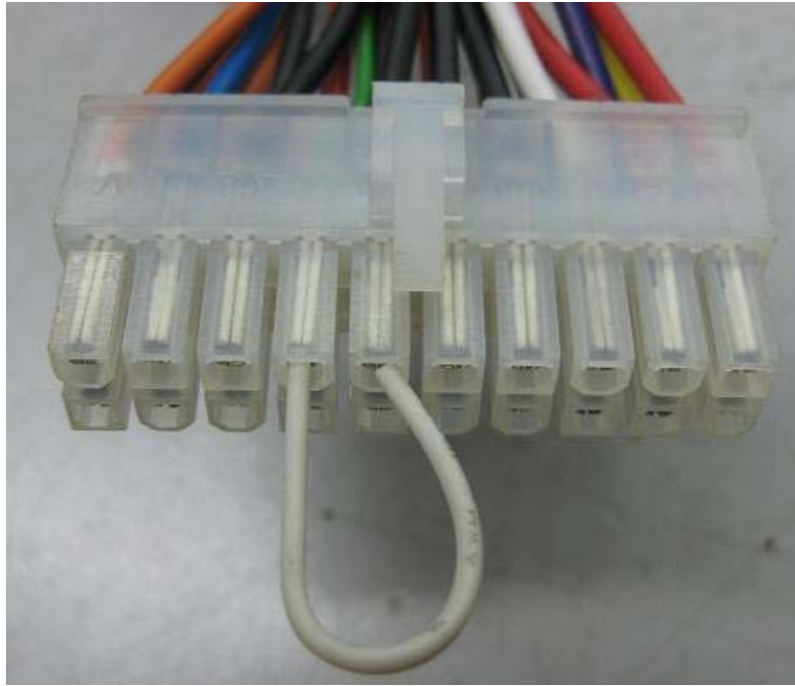
Fewer loads will cause the power supply **not to start** and you may have thought that the power supply is not working. Time will be wasted if you troubleshoot a **working power supply unit** due to that you do not know how to properly test it with a load. Remember, not to test power supplies without load as many ATX power supplies in the market require a load for it to work properly. If you search the Internet for this keyword “ATX Power Supply Tester” you will get some results of websites selling the ATX power supply tester. Figure 19.12 in the next page shows one of the tester and an optional load to substitute the motherboard.



**Figure 19.12- Coolmax ATX Power Supply Tester**

**Note: In certain types of power supply design, the power supply would not start up until you have connected the power supply to the original load which is the computer system itself. If you connect to other types of motherboard (although has the same connector) the power supply either totally cannot start or the fan would turn a little bit and stop. So you must test the particular power supply with the right load.**

Next, you must know which one is the PS\_On pin (Green wire) of the power supply. **In order to power up the PSU for testing, you need to short PS\_ON pin with one of the common pins (ground pin).** Normally, PS\_ON is activated when you press and release the computer power button while it is in standby mode.



**Figure 19.13- This Is How You Connect A Wire Between The Green Wire And Ground**

A lot of PC power supplies failures are actually simple problems that are easy to fix. The **common problems** of power supplies are failures in the **filter capacitors (bad ESR or bulged) and shorted output diodes** in the secondary side. Dry joints could also cause the power supply to stop working or causing intermittent problem. **Before you begin to repair any power supply, you must understand about the safety precaution first.** If you don't know what you are doing or **not confident** about the repair, then please stop now until you have someone to guide you by your side. Please make sure that you know how the power supply works and **how to accurately test the electronic components** in the power supplies for higher chances of repair rate.

However, if the power supply has too many burnt components in it then replacement with a new unit is the best solution.

## Problems In ATX Computer Power Supply

Switch mode power supplies aren't typically too hard to repair. They tend to fall into some categories:

### **1) Dead And Silent With Fuse Blown**

Once you have opened up the casing and found that the fuse has blown, you have to expect some serious problem in the power supply unit. Of course there are also chances that the fuse has **blown by itself due to life span of the fuse or from a mild surge**. You may need to use the light bulb method as explained in chapter 13 to see if the problem is only the fuse or it could be some other components' fault.

From experience, if you have discovered that the fuse blown, please check on these components like Varistor, Bridge rectifier, Big filter capacitor (swollen, leaked, open or short circuit), switching transistor, power IC and secondary output diodes (Schottky diodes) for short circuit. If you find shorted components anywhere in the primary side, you should also check the resistors for open circuit and replace as necessary. Do replace the bad components; fix any cracked solder joints, reassemble and then you are ready to test it. Use the light bulb method as explained in chapter 13 before you begin to put in the fuse and turn it On. Sometimes a severed power surge could cause the **Varistor** and the **Thermistor** to **split open**.

If you found that the primary side components burnt beyond recognition, (quite common if the SMPS was hit by lightning and had a major short circuit problem) you may need to refer to chapter 16 for further action.

### **2) Dead And Silent With Fuse Good**

If the Main Fuse is **Okay** then I suggest that you check for an **open start up resistor** in the primary side (common problem) and also for a leaky switching transistor. Directly replace the power IC as we can't accurately test the power IC with ohmmeter. A direct short circuit of the secondary output diodes could also cause no power symptom.

### **3) Power Chirping With Fuse Good**

Chirping supplies (you could hear the sound of chirp-chirp-chirp) generally means there is a problem with the output. Shorted secondary

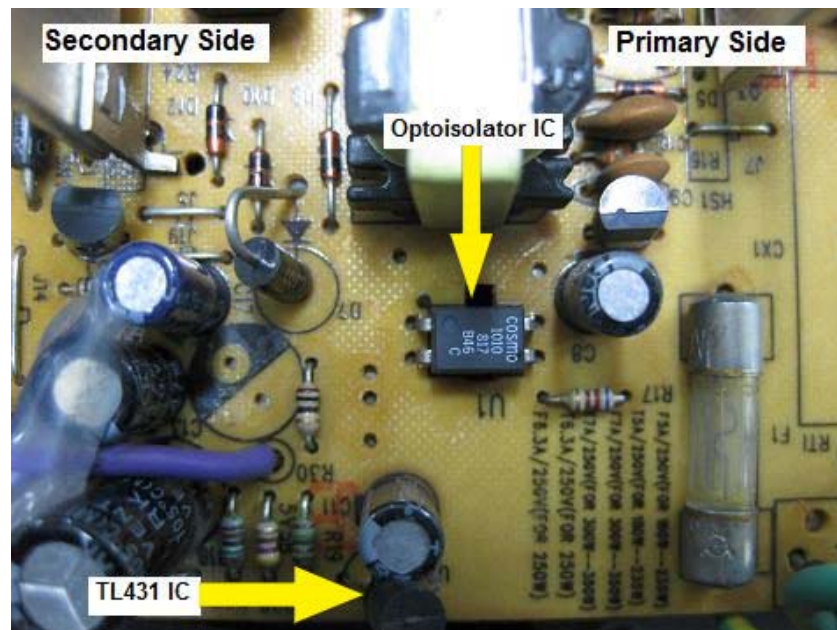
output diodes (Ultra fast or Schottky diodes) are the main cause of power supply chirping.

#### 4) Power Cycling

By placing the test probe at the output connector, you will notice that the voltage reading goes up and down. The power supply is in a repeating cycle attempts to start up, but being dragged down by the overload and thus shut down and then the cycle repeats.

Since you could measure the output (although the output voltage is up and down) this suggests that the **primary side switching transistor is working. If it is not working there would be no output at all.** Thus your repair concentration should be in the secondary side. Check on the secondary output diodes and filter capacitors.

If the SMPS used power IC in the primary side, try checking the corresponding components like diode, current sense resistor or even the electrolytic capacitors before you replace the power IC and retest the power supply. If the SMPS used a Power IC, generally there would be a feedback circuit that uses the Optoisolator IC for regulation purposes. Check all the components in this area or even directly replace the Optoisolator IC and TL431 IC and retest the power supply.



**Figure 19.14- SMPS Feedback Circuit**



**Note:** Many computer SMPS require a minimum load to maintain stability and to provide proper regulation, thus when there is not enough load (under loaded), the power supply may be **cycling due to overvoltage**. Make sure that the load is enough otherwise you may be **troubleshooting on a working SMPS** and this would waste your precious repair time.

### 5) Fan Turns A Little Bit And Then Stops



**Figure 19.15- The Fan Turns For A While And Then Stops**

This suggests that the power supply is trying to start but because of faulty components in it, the power supply shuts itself off. In this case most probably the problem is in the secondary side. Bad ESR in secondary filter capacitor and capacitor bulged are **very common** in causing this kind of problem. These capacitors are specially designed to handle the rigors of filtering in a switch mode power supply and make sure that you test all these filter capacitors with an ESR meter.

Any capacitor that is swollen or leaking should be replaced. Faulty PWM IC (i.e.; TL494CN IC and etc) and corresponding components like resistor turned into high ohm could cause similar problem too. Don't overlook that the regulation and the feedback circuit components which includes the Optoisolator IC (if the circuit has one) may also contribute to such problem. Check that the power supply is connected to a load (or original load) if not, the power supply fan would turn for a while and then stop.

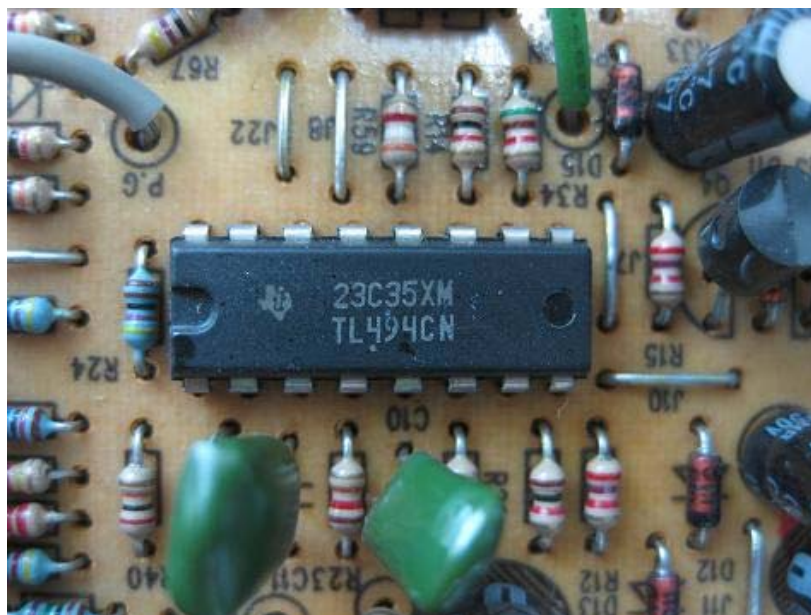
**6) High Pitched or Hissing Sound Problem-The power supply was working good (with good outputs) but it produced an annoying high pitched sound.**

If the power supply is working good and you hear the high pitched sound then the problem could be in the SMPS transformer or from the secondary side inductor. If the transformer or inductor was not wound tightly and secured, they would vibrate. Try gently knocking on the transformer and the secondary side inductor with the handle of a screw driver while the power supply is running. If the sound goes away then I guess you have to remove either the transformer or the inductor (whichever one that produces the sound) and dip it into **shellac** and let it dry for a day. This method will usually get rid of the high pitched sound.

### **Components Replacement**

If possible, get back the same part number to avoid repeating failures in SMPS that you have repaired and also to maintain the specifications within acceptable limits with respect to line isolation and to minimize fire hazards. However, if you still could not get the exact replacement part, then the only option you have is to get the nearest possible replacement part for substitution. Please refer to chapter 6 on how to get a replacement part number to insure reliable operation of the SMPS.

### **External Voltage Test Method**

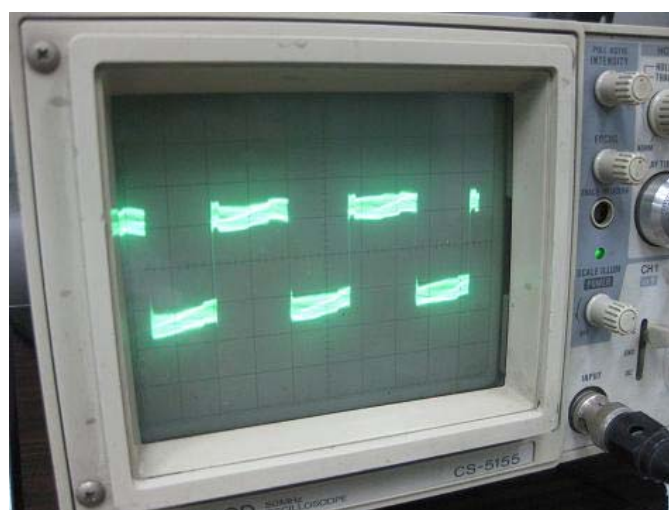


**Figure 19.16- A TL494CN PWM IC In SMPS**

If you come across any power supply that uses a PWM IC in the secondary side i.e. TL494CN then you can perform the following test to make sure it is good because if it doesn't work, there will be no power. The PWM TL494 IC is the one that drive the switching transistors in the power supply. Although we don't use oscilloscope in every SMPS repair, without it we may have some disadvantages especially in checking for the right signal or waveform. The problem with SMPS is that if the SMPS would not work, then **how do we use the oscilloscope to test out the waveform?** The solution is to use an **external voltage source** to power up the PWM TL494CN IC and check for the waveform.

First, check from the data sheet to see what is the DC voltage to power up the IC. Your ultimate aim is to supply the IC with the right voltage so that you could measure the waveform with your oscilloscope.

Now, connect a **12 volt dc supply** to the input pin (pin 12) of the IC and the negative to pin 7 (ground pin) or to the secondary cold ground. If you do not have a DC power supply, **you may use batteries** to power up the IC- it works too! Once the 12 volt is applied to the IC, use your scope to check the output waveform at pin 8 and 11. You should expect an active square waves as seen in figure 19.17 in the next page. If there is no output, **try ground pin 4** (dead time control pin) and check again the output. If there is still no output, do replace the IC and retest. **Do not overlook that sometimes a shorted or bad components that correspond to the IC could cause no output.** For example, a bad LM339 comparator IC or an open resistor in the corresponding circuit could cause no output from the PWM TL494CN IC.



**Figure 19.17- A Typical Squarewave Waveform At Pin 8 and 11 Of PWM IC TL494CN**

This method will eliminate problem to someone who is afraid of doing troubleshooting while the SMPS is “On”. They are afraid of dealing with the high voltage thus this method would suit them the most.

**Note:** You can't use this method to test on all kinds of PWM IC because most of the PWM IC has a feedback pin. That means if by just applying only DC voltage to the PWM IC without any signal to the feedback pin, no waveform will be produced. You have to make your own test from the information that you get from the IC datasheet and see the result for yourself because there are **too many PWM ICs** in the market.

## **20) ATX Power Supply Repair True Case Histories**

### **1) No power**

#### **Case no 1:**

Most electronic repairer knows that whenever there was a complaint of no power by customer, the first thing he or she will do is to check the fuse first with an ohm meter or with a continuity test. In this case, the main fuse was found to be bad and I did not stop there. I continued to look for any burnt components, bulged capacitors, loose joints and etc. I have also tested on some of the major components like bridge rectifier, switching transistor, Varistor (A shorted Varistor tends to blow up the main fuse) and secondary output diodes.

Since all other components were tested good, I connected a 100 watt light bulb across the fuse holder solder pad points and On. The light blinks for a while and then went off. This was a good sign that there was no major short circuit in the SMPS (please refer to chapter 13) on light bulb test. I then removed the light bulb and put in a new fuse and power on. The SMPS came back to life indicating only fuse problem and no other serious fault in the circuit.

**Note:** This is my normal procedure of troubleshooting any type of SMPS **whenever I come across a faulty fuse**. A bad fuse is not necessary due to a heavy short circuit. As mentioned, a fuse could go open circuit because of its life span and possibly from a mild surge.

#### **Case no 2:**

The complaint was no power; it was because the fuse had an open circuit. As usual when found that the fuse was not working, I would test on the other major components. The result was the two switching transistors (MJE13007) had shorted and both were mounted on the heatsink (as shown in figure 20.1 in the next page). Further check reveals two fusible link resistors (2.2 Ohm) also had an open circuit.



**Figure 20.1- Power Transistors In ATX Power Supply**

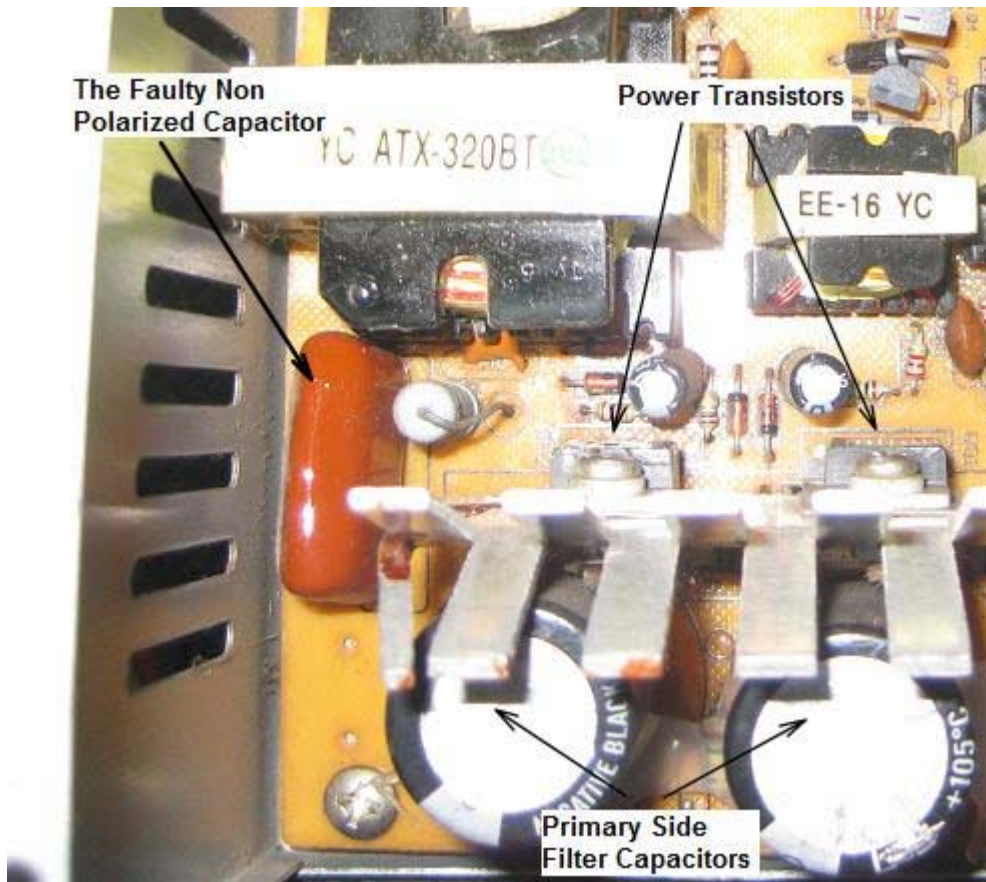
Please refer to case no 1 about connecting the light bulb before you switch “On” the power supply. Replacement of the 5 components (2 transistors, 2 resistors and 1 fuse) restored the problem.

**Note:** It is quite common when the fuse blown, the bridge rectifier or even the Thermistor and Varistor also will go shorted. Check the Varistor and Thermistor for cracks and pinholes. In some cases, the secondary output diodes might be destroyed too.

### **Case no 3:**

The complaint was that there was no power but the fuse was working. Since the fuse was good, this shows that there were no major short circuits in the SMPS. Before performing any voltage test, I would usually check on the primary side components like the start up resistor, filter capacitor, non polarized capacitor and even direct replacement of the power IC and retest the SMPS. I will also scan for any short circuit in the secondary side output diodes too.

In this case, I found a non polarized capacitor in the primary side with the value of 0.47uf 250 volts dropped to 0.15uf when tested with digital capacitance meter. A replacement solved the no power symptom.



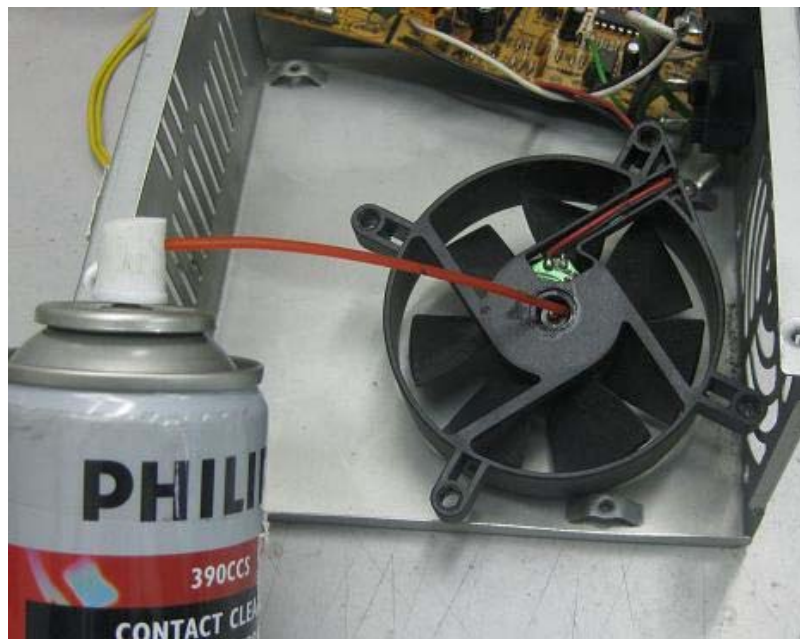
**Figure 20.2- A Faulty Non Polarized Capacitor Can Cause No Power Symptom**

**Note: - Any components found defective in the primary side could cause a dead power supply symptom.** Make sure you test on all the components in the power side and if all components were tested good, then directly replace the power IC (if the power supply used the Mosfet Technology) and retest the power supply. Some ATX power supplies may take you a longer time to troubleshoot because of ‘too many’ components in the board. The most frustrated part was that you could not get the spare parts especially the power IC. Even if you could locate one, the price would be sky high and if this happens, I will usually get the customer to buy a new unit since nowadays the price of a new power supply is quite cheap.

## **2) Intermittent No Power**

This ATX power supply came in with the complaint of intermittent no power. When tested it with power on, I could see that the fan was not working. Not only that, some filter capacitors also became bulge because of the heat accumulated inside the power supply. The failure of the fan

could not suck out the heat generated by the components especially the switch mode power transformer, power transistors and output diodes. If you switched off a working power supply and with the ac power cord removed; and if you touch the power transformer, you could feel that the power transformer was actually quite hot. Another heat source would be the heat sink, where the power transistors and output diodes attached to it. Secondary output Diodes run a little bit hot in filter circuit than diodes in other circuits due to the **high current present** at the secondary output line.



**Figure 20.3- The Right Way To Service The SMPS Fan**

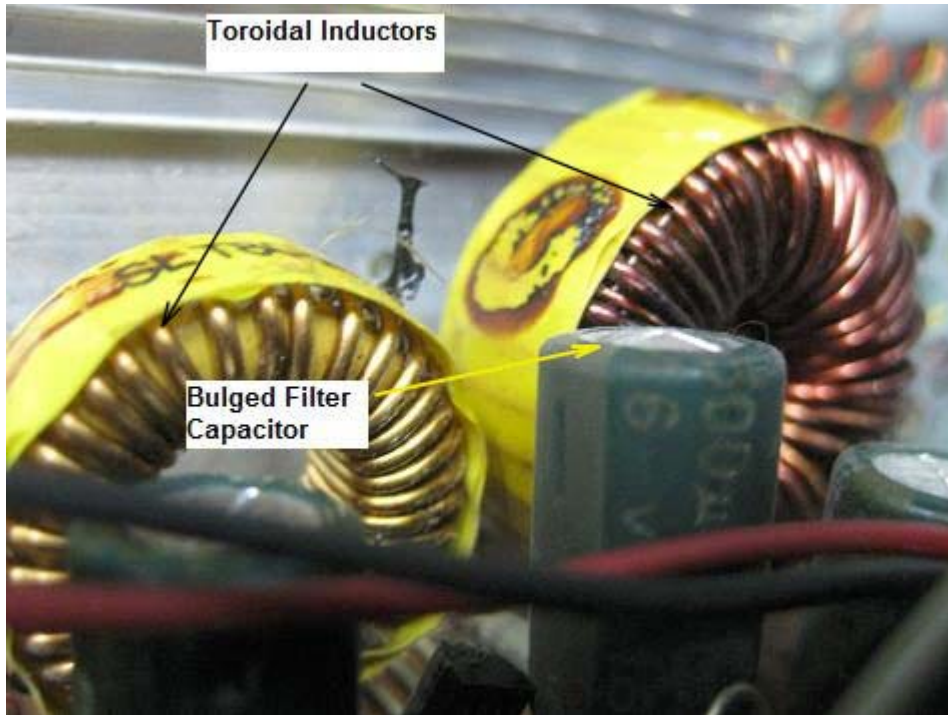
As for the malfunctioned fan, you could use a Philips oil based contact cleaner to service the fan. The grease inside the fan would run dry after serving for sometimes and eventually stop rotating. Remove the back plastic cap of the fan and spray it with the contact cleaner and you would be surprised that the fan could regain its glory. It will actually work just like a new fan. If it still doesn't rotate, the best choice is to replace with a new fan. If you have the power supply at your work place then you could salvage the fan and install it.





**Figure 20.4- Decayed Glue Found In ATX Power Supplies**

From the photo above, you could see those decayed glue that stick besides the components. Manufacturers purposely use some kind of glue to apply on the components. They think those components will shake or come out when there is vibration or during shipping. The heat generated inside the equipment will **turn the glue into conductive** after a few years in service and sometimes would even corrode the pins of the components and eventually cause the equipment to have intermittent problem or totally stop working. Scrap the decayed glue off with your test pen and use a Thinner solution to clean the PCB board.



**Figure 20.5- Bad Output Filter Capacitors Could Cause Intermittent No Power Problem**

After the replacement of the filter capacitors at the secondary side, with the decayed glue removed and fan serviced, the ATX power supply again was given a new life to faithfully serve the computer.

### **3) Higher Than Normal Output**

#### **Case no 1:**

When the power supply was switched on, measurements were taken. The results were over voltage. The 12 volts line shot up to 13 + volt and the 5 volts line became 5.6 volts. After the casing was removed, I noticed that the internal part was **very dirty** and I used a vacuum cleaner and a brush to clean off the dirt. Four filter electrolytic capacitors in the secondary side had bulged. The values of the filter capacitors were 1000uf 10 volt and 2200uf 10 volt.



**Figure 20.6- Dirt Inside The Power Supply**



**Figure 20.7- After Cleaning With A Vacuum Cleaner And A Brush**

As you know, we as electronic repairers can't just see things at **only one side**; we have to see the **other side too**. What I mean is that try to see if there are any more suspicious components that contribute to the failure of the power supply such as broken components, dry joints, loose connection, decayed glue and etc before the replacement of the four bulged filter capacitors.

Some components were covered with decayed glue. I had to carefully remove it by scrapping off the layers of the decayed glue. Once it was done, I cleaned the PCB board with the Thinner solution. As mentioned, decayed glue could cause serious or intermittent problem in electronic equipment because it **could be conductive**.

If you repair any ATX power supply, make sure you check the fan too. Please refer to page 248 on how you can service the fan.

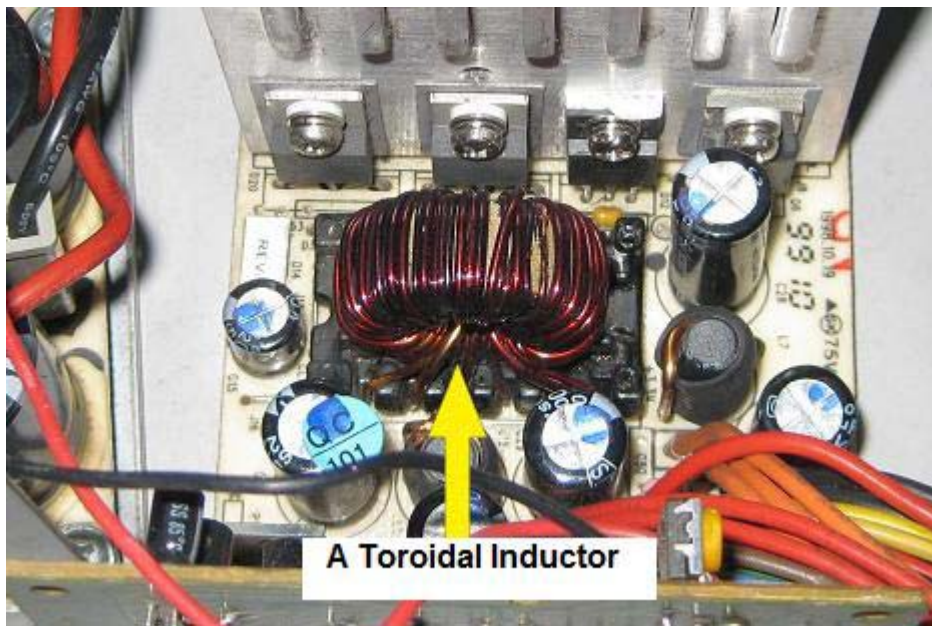


**Figure 20.8- The Four Faulty Filter Capacitors**

Once the four electrolytic capacitors were replaced and the decayed glue removed, the power supply worked like a charm.

## Case no 2:

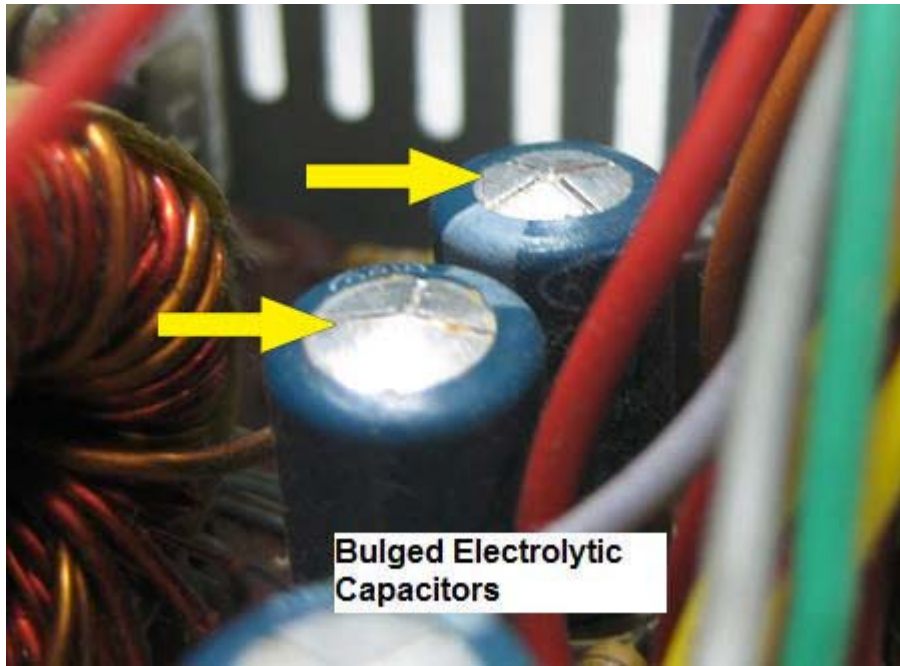
If you found one of the output voltages were higher than normal, say from 5 V to 6 V or from 12 volt to 13 or 14 volt then checked for bad filter capacitors and surrounding circuitry. If all were tested good, do replace the Toroidal inductor as seen in figure 20.9 and retest the power supply. I have personally replaced quite a number of Toroidal inductors that had caused the output voltages to increase.



**Figure 20.9- Replace the Toroidal Inductor If All Corresponding Components Were Tested Good**

### **4) All output voltages were good but with some extra load (connected two additional hard disks) the power supply will shutdown.**

This problem clearly indicates the secondary filter capacitors have a problem because it can't sustain additional load. True enough, when the casing was opened, I found out that a few of the electrolytic capacitors had bulged. For your information, if the capacitors are good, then you have to test it with an ESR meter.



**Figure 20.10- Bulged Electrolytic Capacitors**

**Note:** Do not overlook the fact that sometimes bad capacitors in the primary side (be it an non polarized or polarized capacitor) could cause the power supply to shutdown when extra load is connected.

#### **5) High pitched sound from the transformer**

This power supply was working well except that it produced an annoying high pitched sound. I suspected it was the transformer problem. Before I removed the transformer and dipped it into **shellac** as explained in page 242, I would usually scan some of the components first. I found two electrolytic capacitors with the value of 1 uf 50 volt had problem (bad ESR) in the primary side and the new parts solved the high pitched sound problem.

**Note:** Before dipping the transformer to the shellac, make sure no other components have problem especially the electrolytic capacitors (check the electrolytic capacitors with ESR meter) otherwise it still would not solve the problem because the problem is in the capacitors and not in the transformer. This will surely **waste your precious time**.

#### **6) Power transformer has sound and the output voltages very low.**

Here are the voltages measured at the output:  
Power good measured 0 volt

+5 volt measured +1.6 volts  
+12 volt measured +4.6 volts  
-12 volt measured -3.6 volt  
-5 volt measured - 1.4volts

This power supply used the half bridge topology where a pair of power transistors (2SC3039) was used to switch the high voltage supplies across the primary winding of the SMPS transformer. Since there were some voltages at the secondary side, this **suggests that the primary side was good**. Because of this, my concentration was at the secondary side but I found nothing wrong with the secondary output diodes. I then moved on to test the small signal diodes (1N4148) at the input of the small transformer and found that both of the diodes had shorted. By replacing the two signal diodes made the SMPS work again.



**Figure 20.11- Low Output Voltages Could Be Caused By Shorted Signal Diodes In The Secondary Side**

**Note:** Not necessary the secondary output diodes shorted could cause sound in the transformer. It can also be some other shorted components like transistor, PWM IC, and capacitors. Do not overlook that resistors in the secondary side that have an open circuit or turn into high ohm could also cause similar symptom.

### **7) Output voltages were low and there was no sound from the transformer.**

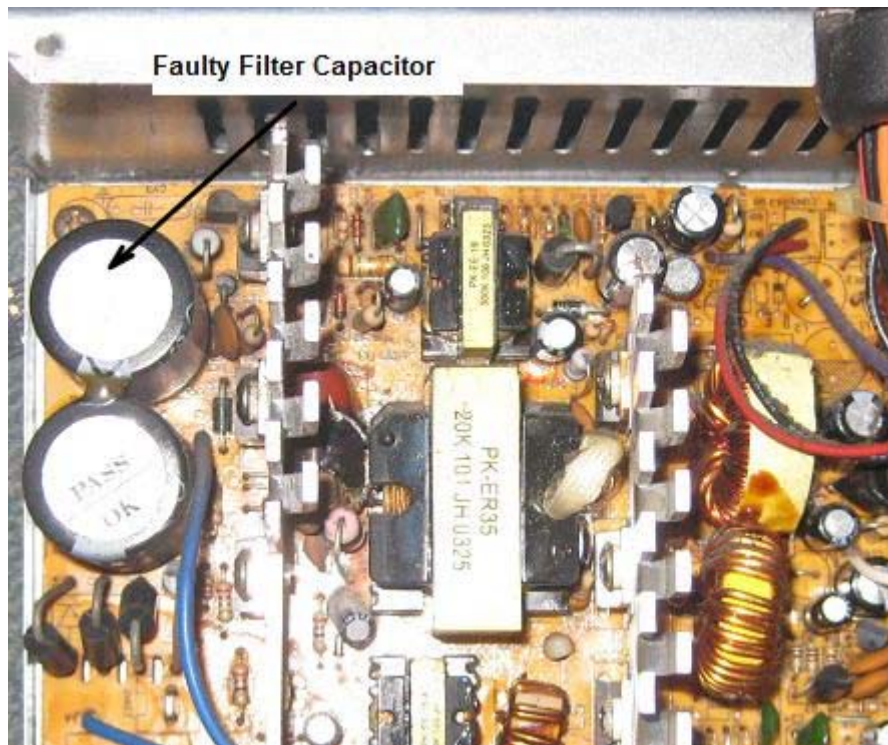
The output +5 volt became 2 volt; the 12 volt became 7 volt and power good signal was 0 volt. The fan could rotate (quite slowly but did not stop) and once the power supply was connected with extra load (hard disk) the fan **stopped and power shut down.**

This problem normally was the cause of bad secondary filter capacitors but somehow **all the capacitors were tested okay.** Since there were voltages at the output, this suggests that the **switching transistors were good.** It could also be some other component failure in the primary side that could affect the “on” time of the switching transistor thus producing a lower than normal output. Usually, capacitors in the primary side tend to have problems, so I checked on the non polarized capacitor first. Guess what? The non polarized capacitor .47uf 250v capacitance value became .19uf causing the SMPS to produce a **lower output.** Please refer to figure 20.2 to see where the non polarized capacitor is located.

### **8) No power good signal but all other voltages was good**

Normally, when there is no power good signal (gray wire), we will trace back from the wire and check to see which location the signal was lost or to see if the signal source has any problem or not. But in this case, it seems that all the secondary side section was okay. I did not give up and try to check the primary side just in case if there is problem in the components. I knew the chances were quite slim because the SMPS has all the output (which means the primary side is working) **except the power good signal only.** I went ahead and test the big filter capacitor and surprisingly **one of the big filter capacitors** has problem. The value is 470uf 200 Volt and a replacement brought back the 5 volt power good signal.





**Figure 20.12- One Of The Filter Capacitor Problem Could Cause No Power Good Signal**

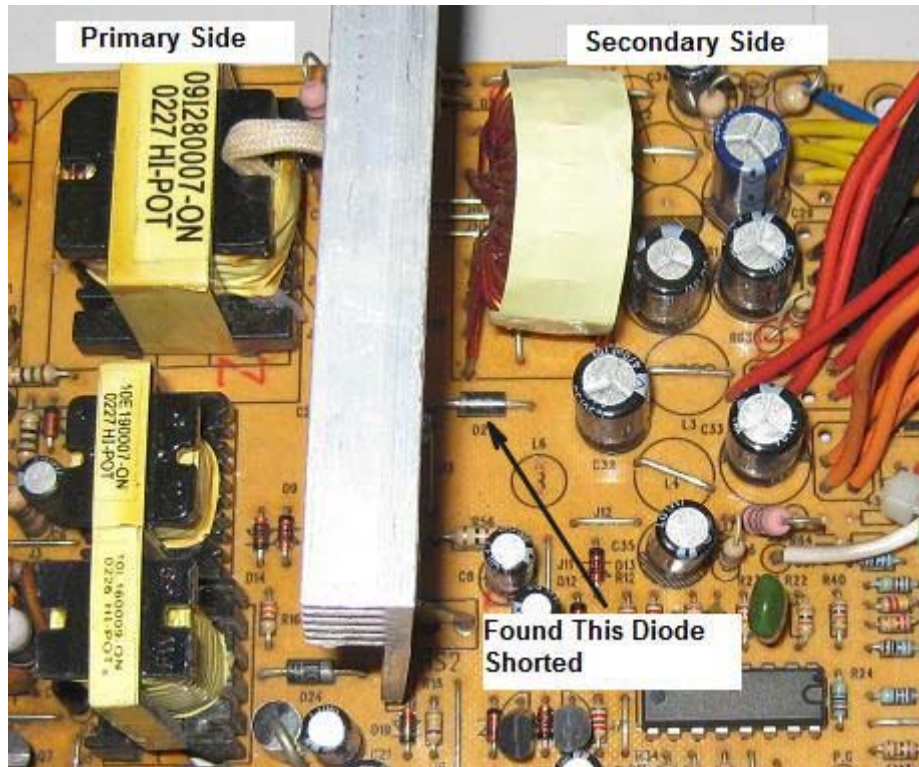
**Note:** Sometimes when you think that the problem lies in the secondary side it could also have **some percentage of failure in the primary side**. If you have exhausted finding fault in the secondary side, then try the primary side and vice versa. In the above case, I believed the ripples which were not removed by the big filter capacitor had entered into the secondary side causing problem to the power good signal.

**9) Fan rotates a bit and then stopped and the transformer has sounds.**

**Case no 1:**

As usual, whenever I come across this problem I will check on the secondary side filter capacitor with ESR meter and the secondary output diodes. Since the filter capacitors were tested good, I then proceed to check on the secondary output diodes. I will remove the big SMPS transformer and then check all the secondary diodes. The reason I removed the SMPS transformer was that I could test all of the secondary diodes (ultra fast recovery diode and Schottky diodes) on board without removing one of the diode leg. Secondly, sometimes I do come across decayed glue located underneath the transformer output pins and it will cause intermittent problem and you could hardly see the decayed glue from the top.

Checking all the diodes this way will give you a **more accurate** reading as compare when you check the diodes on board. Off course you can remove one lead in all the secondary diodes and test it with your meter- it's your preference. In this case, I found a diode shorted in the -12 volt output line (blue wire) and a new diode cured the problem.



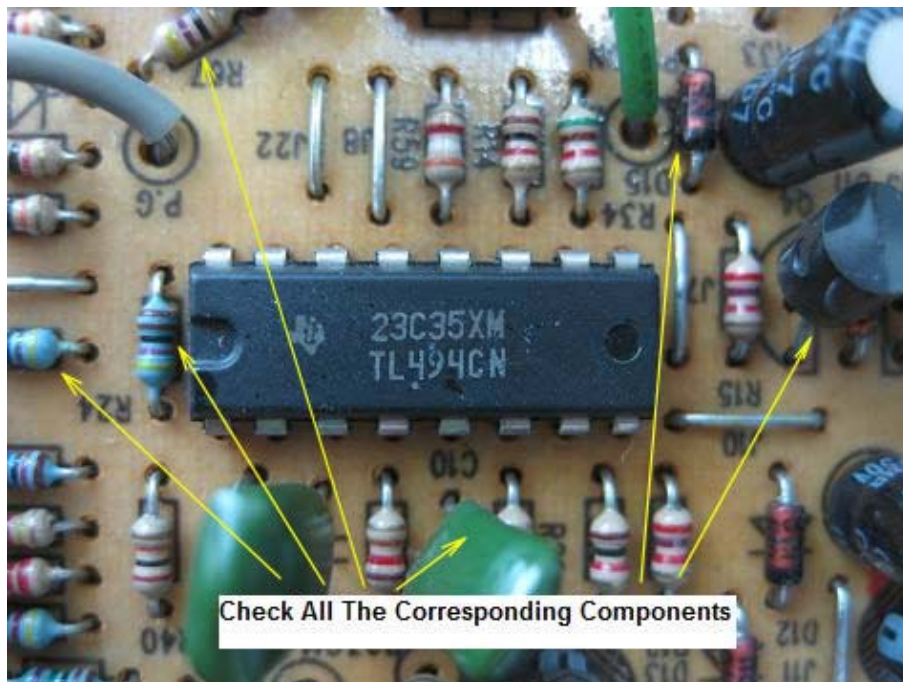
**Figure 20.13- A Shorted Diode In The Secondary Side Could Cause Fan To Turn A Bit And Stop**

**Note:** Please do not think that every time when there is a complaint regarding the SMPS fan turning a bit and then stop, it must be the cause of a shorted secondary diode or bad filter capacitor. It could be due to other causes too- please read the next case to see what the solution to the problem is.

**Case 2:**

First I thought it was one of the secondary output diode that was problematic but I found all of them were good. The secondary output filter capacitors were tested good too and the PWM TL494CN IC was replaced with no improvement. My concentration now was to check on the corresponding components of the PWM TL494CN IC. All components with one leg were lifted up and tested with meter and found two resistors had problem. A 47k Ohm that was connected to pin 14 of the PWM TL494CN IC changed to 70 over K Ohm and another resistor

4.9 K Ohm that was connected to pin 1 of the IC had an open circuit. By replacing these two resistors brought the power supply back to life.



**Figure 20.14- Faulty Corresponding Components Could Cause Fan To Rotate A Bit And Stop.**

**Note-** It is not necessary whenever the fan rotates a bit and then stops, it must be the cause of shorted secondary output diodes. From the solution given above; it turned out to be the bad components that were located surrounding the PWM TL494CN IC. The PWM IC could turn out to be **any part number** and it depends on what model and type of power supply you are working on. A **shorted** PWM IC could also cause similar symptom too.

## **Is It Worth To Repair Computer ATX Power Supplies?**

Many questions arise whether one should continue to repair Computer Power Supply or not since a new unit is quite cheap nowadays. As for me, I had stopped repairing ATX power supply as the cost of a new unit is very cheap. It's not worth repairing because the spare parts sometimes are much more expensive than getting a new power supply. Searching for ATX power supply spare parts was not easy as many of them couldn't be found from the Internet as not only that as many complicated and

different designed by power supply manufacturers had used up our precious troubleshooting time. We need time to understand how all these different designed power supply works.

As manufacturers want the design to be made into compact size, many secondary or even primary power supply circuit are built into a modular board (smaller board). This made troubleshooting even more difficult because many times the meter's probe can't reach the testing point.

The real reason why I had stopped repairing ATX power supply was the profit margin. If you charged too high, the customers would rather buy a new unit that comes with a one year warranty. If you charged too low, you may end up in the losing side because of the components replaced, electricity and etc. If you charge a reasonable fee, the profit margin gained cannot even cover your time spent on troubleshooting it. I'm here not to discourage you to stop repairing ATX power supply. **However, if you have the time, contacts of getting cheap power supply components, easy to access many power supply schematic diagrams and etc then you may go ahead to repair it.** If your reason of repairing power supplies is to **improve yourself with troubleshooting skill and experience** and not for the profit purposes then you are encourage to repair the power supplies.

Conclusion- There are many designs of Computer ATX power supply in the market, thus you **must be flexible** on how to troubleshoot them. The true case histories were just a guide to show you on how I tested, troubleshoot and repaired the power supplies. You may encounter power supplies with the same problem as in the true case histories but you may also encounter new problem that you haven't seen before. No matter what the problem is, just **reread my book again** and follow the procedure and use your imagination on how to access to the bottom side of the printed circuit board. You have to do it carefully because twisting and turning the PCB board too many times can cause attached wires (the AC or the output wires) to break loose.

I've fixed thousands of switch mode power supplies over the years and from experience, I could say that the more you work on power supplies, the better you are. I also believe that, the more time you spend on reading this book you will definitely be able to solve many problems in Computer ATX SMPS. **Keep the safety precautions in mind and make sure the filter capacitors are discharged and you should be safe.**

Part V

# Miscellaneous

## **21) Understanding Power Supply Glossary**

### **Term**

AC (Alternating Current) – A current that periodically reverses its direction of flow. The electricity supply to homes, offices, factories and etc. is AC.

AC Line – A power line that delivers alternating current only.

AC Line Filter – A filter designed to remove extraneous signals or electrical noise from an AC power line, while causing virtually no reduction of the power line voltage or power.

AC Line Voltage – The voltage commonly delivered by the commercial power line to consumers. In the United States, the two standards are 117V and 234V (~ about 5 percent). The lower voltage is used by most appliances; the higher voltage is intended for appliances and equipment that draws high power, such as electric ovens, cooking ranges, clothes dryers, and amateurs-radio amplifiers. In Europe, 220V is the common standard.

AC Noise – Electromagnetic interference originating in the AC power lines or electrical noise of a rapidly alternating or pulsating nature.

Active Component- A device capable of some dynamic function (such as amplification, oscillation, or signal control) that usually requires a power supply for its operation. For examples: bipolar transistors, field effect transistors (FET) and integrated circuit (IC).

Attenuates- To reduce in Amplitude

Bleeder- A resistor or group of resistors, used permanently to drain current from charged capacitors. It establishes the predetermined initial load level for a power supply or signal source, and it serves a safety device in high voltage power supplies.

Crest Factor - This is the ratio between the peak current and the average current required by the load. Computers normally exhibit a crest factor of 2 to 3, which means the computer draws two to three times the average current for short duration, such as the starting time etc.

Current - It is a quantitative measure of the amount of electricity passing through a circuit or the movement of charge carriers, such as electrons, holes, or ions. The unit for measuring the current is Amperes.

Current Limiting – The controlling of current so that it does not exceed a desired value.

Current Limiting Resistor- A series resistor inserted into a circuit to limit the current to a desired value.

Current Meter – A normally direct-reading instrument, such as an ammeter, milli ammeter, or micrometer, used to measure current strength.

Current Noise – Electrical noise produced by current flowing through a resistor.

DC (Direct Current) - It has either a positive or negative polarity and flows in one direction. A DC charge can be stored more easily and is used for all batteries.

DC Power Supply – A power unit that supplies direct current only. Examples: battery, transformer / rectifier / filter circuit, DC generator, and photovoltaic cell.

DC Voltage- A voltage that does not change in polarity, an example being the voltage delivered by a battery or dc generator.

DC Working Voltage- The rated dc voltage at which a component can be operated continuously with safety and reliability.

EMI- Any electronic device generates electromagnetic waves. If such electronicmagnetic waves interfere with another device through spatial radiation or a power cord, it is called EMI or Electromagnetic Interference.

ESR- ESR stands for Equivalent Series Resistance and is an effective resistance that is used to describe the resistive parts of the impedance of certain electrical components.

Impedance - It is combination of resistance, inductance and capacitance which restricts the current through any device.

Inverter - It is a circuit which converts DC to AC.

**Line Frequency** - It is the number of times the AC flows in one direction during one second. Frequency is measured in Hertz (Hz) or cycles per second. The standard power frequency may differ. For example the AC frequency in Malaysia is 50Hz. (i.e. the current changes its direction 50 times per second) while in the U.S.A. it is 60 Hz.

**Line Loss**- The sum of energy losses in a transmission line.

**Line Noise**- Electrical noise (as received by a radio) arising from fluctuations of current or voltage in a power line.

**Passive Component**- A device that is basically static in operation (it is ordinarily incapable of amplification or oscillation and usually requires no power for its characteristic operation). For example: resistor, capacitor, diode inductor, fuse and rectifier.

**Power Factor** - This is the ratio of real power to apparent power (VA/watts). The power factor can be 'leading' or 'lagging' depending upon the type of load. Inductive loads cause the current to lag and capacitive loads causes the current to lead the voltage.

**Power Factor Meter** – An instrument that gives direct readings of power factor (lead or lag). One such meter uses a dynamometer-type movement in which the rotating element consists of two coils fastened together at right angles.

**Power Line Frequency**- The frequency of the alternating current and voltage available over commercial power line. In the United States, the power frequency is 60 hz while some countries is 50 hz.

**Power Rating** – The specified power required by equipment for normal operation.

**Power Supply** – A device, such as a generator or a transformer-rectifier-filter arrangement, which produces the power needed to operate on electronic equipment.

**Power Surge**- A momentary increase in the voltage on a utility line.

**Power Switch**- The switch for controlling power to a piece of equipment.

**Power Transistor** – A heavy-duty transistor designed for power-amplifier and power-control service.



PWM - Pulse Width Modulation is a technique employed to regulate the output power by changing the pulse width. PWM is employed in SMPS, UPS and many other power control applications.

Rectifier - It is a diode network which changes AC to DC. The process of changing the AC to DC is called rectification. This is the reverse of an inverter which converts DC to AC.

Ringings- Self oscillation in a pulsed inductance-capacitance circuit, sustained by the circuit's flywheel action, and usually producing a damped wave.

Ripple- A small alternating current component in the output of a direct current power supply with inadequate filtering.

Sine Wave - It is the most simple of all wave forms and is the shape of the AC in homes, offices etc. In a sine wave, the voltage or current changes smoothly from a negative maximum to a positive maximum with changing time.

Square Wave - This waveform is similar to the sine wave except that the transitions from negative maximum to positive maximum are abrupt. Most domestic inverters supply a square wave as it is simple to generate.

Surge Suppressor. A semiconductor device used to absorb potentially destructive transients or over voltages on a utility power line.

Transformer - A device used to convert an AC voltage to different AC voltage levels. A transformer is also used to isolate the output AC power from the source.

Transient- A sudden high voltage spike in an alternating current system, caused by arcing or lightning

VA (Volt Ampere) - This is the simple product of voltage and current and is used to express the amount of power. VA gives the apparent power.

Voltage - It is a measure of the potential difference between two points, it is what causes the current to flow from a higher potential. This is measured in volts.

Voltage Breakdown-The voltage at which current suddenly passes in destructive amounts of dielectric.

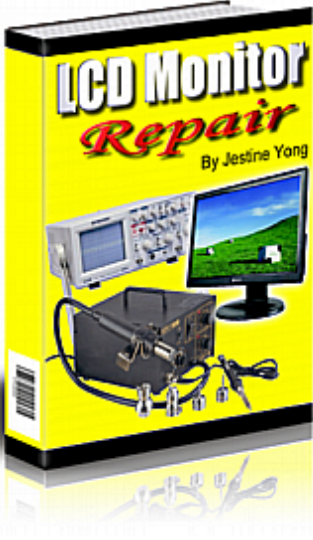

Wattage - This is a measure of energy drawn per second by the load. It is calculated by multiplying the VA by the power factor ( $VA \times pf$ ). This gives the true power. The pf varies between 0 for ideal inductive and capacitive loads to 1 for pure resistive loads (incandescent lamps). The pf for a typical computer would be between 0.6 and 0.8 in most cases.

Wattmeter- An instrument used to measure electrical power. The scale usually reads directly in watts, kilowatts, milliwatts, or microwatts.

Wave Form - This is the name given to the shape followed by any alternating current or voltage.

Winding- A coil in an inductor or transformer such as the primary and secondary winding.

## 22) Recommended Electronic Repair Ebook

<p><b>Book Title:</b> LCD Monitor Repair <b>Author :</b> Jestine Yong <b>Pages:</b> 200 <b>Book format:</b> EBook <b>Price:</b> USD47.77 <b>Website:</b> <a href="http://www.LCD-Monitor-Repair.com">www.LCD-Monitor-Repair.com</a></p> <p><b>About The Book:</b> A step by step guide on how you can become a Professional in LCD Monitor Repair. It teach you how you can solve LCD Monitor problems like no power, display dim, display shutdown and many more.</p>	
<p><b>Book Title:</b> Testing Electronic Components <b>Author :</b> Jestine Yong <b>Pages:</b> 166 <b>Book format:</b> EBook <b>Price:</b> USD37.00 <b>Website:</b> <a href="http://www.TestingElectronicComponents.com">www.TestingElectronicComponents.com</a></p> <p><b>About The Book:</b> A step by step guide on how you can test electronic components like a professional. It covers electronics components from resistors, capacitors, transistors up till switch mode power transformer. If you know how to test electronic components, you can start electronic repair work.</p>	

**Book Title:** How To Find Burnt Resistor Value Even Without A Schematic Diagram

**Author :** Jestine Yong

**Pages:** 50

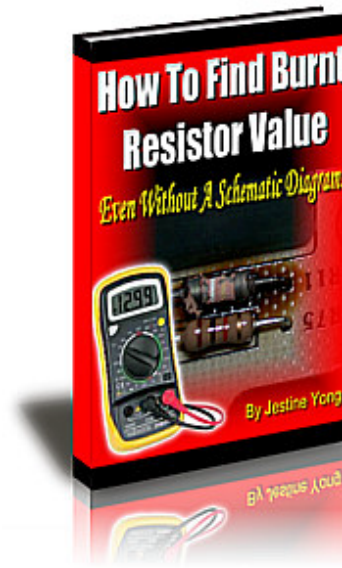
**Book format:** EBook

**Price:** USD24.00

**Website:**

[www.FindBurntResistorValue.com](http://www.FindBurntResistorValue.com)

**About The Book:** How you can find the burnt resistor value in electronic circuit even without a schematic diagram. It comes with diagrams and true case histories to easily help you to locate the value of a burnt resistor.



## **23) Recommended Resources**

1. Power Supply Troubleshooting & Repair By **Lanny L.Logan**
2. Troubleshooting & Repairing Colour Television Systems By **Robert L. Goodman.**
3. Troubleshooting & Repairing Solid-States TVs By **Homer L Davidson**
4. Samuel M. Goldwasser “Notes On The Troubleshooting And Repair Of Small Switch Mode Power Supplies”. Here is the website link <http://www.repairfaq.org/sam/smepsfaq.htm>
5. List of Electronic Spare Parts Suppliers at **JestineYong dot com.** Here is the website link <http://www.jestineyong.com/?cat=12>
6. ATX Power Supply Repair website-  
<http://www.smps.us/computer-power-supply.html>

### **Free Electronic Equipment Schematic Diagrams**

- 1) [www.EserviceInfo.com](http://www.EserviceInfo.com)
- 2) [www.Protech2u.com](http://www.Protech2u.com)
- 3) [www.FastRepairGuide.com](http://www.FastRepairGuide.com)

### **Buy Electronic Equipment Schematic Diagrams**

- 1) [www.Radiolocman.com](http://www.Radiolocman.com)
- 2) [www.justmanuals.com](http://www.justmanuals.com)
- 3) [www.servicemanuals.net](http://www.servicemanuals.net)

### **Electronic Repair Forum**

- 1) <http://forum.eserviceinfo.com>
- 2) [www.Repairworld.com](http://www.Repairworld.com)

### **Electronic Repair Website**

- 1) [www.ElectronicRepairGuide.com](http://www.ElectronicRepairGuide.com)
- 2) [www.Anatekcorp.com](http://www.Anatekcorp.com)
- 3) [www.Epanorama.net/links/repair.html](http://www.Epanorama.net/links/repair.html)

## **Electronic Repair Membership Websites**

- 1) [www.ElectronicRepairGuide.com/Recommend/PlasmaTelevisionRepair.htm](http://www.ElectronicRepairGuide.com/Recommend/PlasmaTelevisionRepair.htm)
- 2) [www.ElectronicRepairGuide.com/Recommend/LCDTelevisionRepair.htm](http://www.ElectronicRepairGuide.com/Recommend/LCDTelevisionRepair.htm)
- 3) [www.ElectronicRepairGuide.com/Recommend/ProjectionTelevisionRepair.htm](http://www.ElectronicRepairGuide.com/Recommend/ProjectionTelevisionRepair.htm)

## 24) Conclusion

I strongly suggest you to reread this information for few times and **start right away** all of the tips and tricks you have learned from this E-book.

If you have questions about Power Supply Repairs or even in electronic repair, please do not hesitate to email me at

[jestineyong@electronicrepairguide.com](mailto:jestineyong@electronicrepairguide.com)

I wish you all the best and look forward to hearing your success story.

**To your success,**

Jestine Yong

Bsc. Eng UK

Author of “Troubleshooting & Repairing Switch Mode Power Supplies”

<http://www.lcd-monitor-repair.com>

<http://www.testingelectroniccomponents.com>

<http://www.findburntresistorvalue.com>

<http://www.electronicrepairguide.com>

<http://www.jestineyong.com>

<http://www.noahtec.com>